

■ Features

- Very low equivalent on-resistance; $R_{CE(sat)}$ 125m Ω at 2A.
- Gain of 400 at $I_c=1$ Amp.
- Very low saturation voltage.

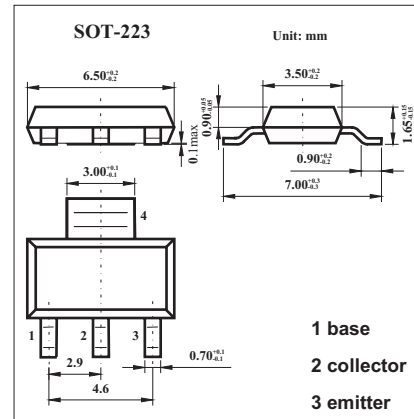

■ Absolute Maximum Ratings $T_a = 25^\circ\text{C}$

Parameter	Symbol	Rating	Unit
Collector-base voltage	V_{CBO}	45	V
Collector-emitter voltage	V_{CEO}	45	V
Emitter-base voltage	V_{EBO}	5	V
Peak pulse current	I_c	3	A
Continuous collector current	I_{CM}	6	A
Power dissipation	P_{tot}	2	W
Operating and storage temperature range	T_j, T_{stg}	-55 to +150	$^\circ\text{C}$

■ Electrical Characteristics Ta = 25°C

Parameter	Symbol	Testconditons	Min	Typ	Max	Unit
Collector-base breakdown voltage	V _{(BR)CBO}	I _C =100μA	45			V
Collector-emitter breakdown voltage *	V _{(BR)CEO}	I _C =10mA	45			V
Emitter-base breakdown voltage	V _{(BR)EBO}	I _E =100μA	5			V
Collector Cut-Off Current	I _{CBO}	V _{CB} =35V			0.1	μA
Emitter Cut-Off Current	I _{EBO}	V _{EB} =4V			0.1	μA
Collector-emitter saturation voltage *	V _{CE(sat)}	I _C =0.1A, I _B =0.5mA I _C =1A, I _B =5mA			0.1 0.5	V
Base-emitter saturation voltage *	V _{BE(sat)}	I _C =1A, I _B =10mA			0.9	V
Base-Emitter Turn-On Voltage *	V _{BE(on)}	I _C =1A, V _{CE} =2V			0.9	V
Static Forward Current Transfer Ratio *	h _{FE}	I _C =100mA, V _{CE} =2V I _C =1A, V _{CE} =2V I _C =2A, V _{CE} =2V I _C =3A, V _{CE} =2V	500 400 100 50			
Transitional frequency	f _T	I _C =50mA, V _{CE} =5V f=50MHz	150			MHz
Input capacitance	C _{ibo}	V _{EB} =0.5V, f=1MHz		200		pF
Output capacitance	C _{obo}	V _{CB} =10V, f=1MHz		16		pF
Turn-on time	t _(on)	I _C =500mA, V _{CC} =10V		33		ns
Turn-off time	t _(off)	I _{B1} =50mA, I _{B2} =50mA		1300		ns

* Pulse test: t_p = 300 μs; d ≤ 0.02.

■ Marking

Marking	FZT690B
---------	---------