

Fan Speed PWM Controller

Features

- Constant Fan Speed Control
- PWM control for stable operation
- Build-in MOSFET switch
- SMBus interface
- Internal short-circuit protection
- On/Off control provided

Applications

- Notebook PC
- Industrial PC
- LAN Switch
- Servers
- Telecom equipment
- Industrial Control

General Description

G760 is a single chip solution for fan speed control, packaged in a space saving SO-8 package. It connects directly to the fan and performs closed-loop control of the fan speed. The only external component required is a 10 μ F capacitor. It determines the current fan speed based on the fan rotation pulses and an externally supplied clock. It uses pulse width modulation (PWM) method and an on-chip MOSFET to control the fan speed to $\pm 2\%$ of the programmed speed. The desired fan speed is programmed via the SMBus. The actual fan speed and fan status can be read via the SMBus. Short-circuit protection is implemented to prevent damages to the fan and this IC itself. An On/Off control pin is also provided.

Ordering Information

PART*	TEMP. RANGE	PIN-PACKAGE
G760A	0°C to +70°C	8-SOP

Pin configuration

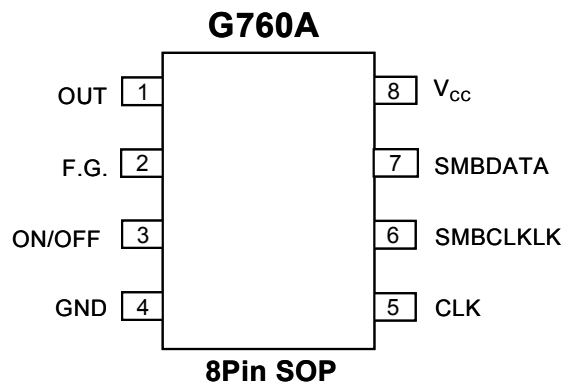

Absolute Maximum Ratings

PARAMETER	SYMBOL	MAXIMUM	UNITS
Supply Voltage	V_{CC}	-0.3 to +7	V
Operating Temperature Range	T_A	0 to +70	°C
Junction Temperature Range	T_J	0 to +125	°C
Storage Temperature Range	T_{STG}	-65 to +150	°C
Lead Temperature (soldering) 10 seconds	T_L	300	°C

Electrical Characteristics (Unless specified: $V_{CC} = 5V$, $T_A = 25^\circ C$)

PARAMETER	CONDITIONS	MIN	TYP	MAX	UNITS
Supply voltage	V_{CC}	4.5	5	5.5	V
Shutdown current	On/Off = 0V		2	5	μA
MOSFET on resistance			0.2	0.25	Ω
Short-circuit current limit			0.5		A
Input logic low	V_{IL}			0.8	V
Input logic high	V_{IH}	2.4			V
Average Output current				350	mA
FG input Positive-going threshold voltage	$V_{CC}=5V$		1.8		V
FG input Negative-going threshold voltage	$V_{CC}=5V$		0.7		V
FG input Hysteresis voltage	$V_{CC}=5V$		1.1		V

Application Circuit

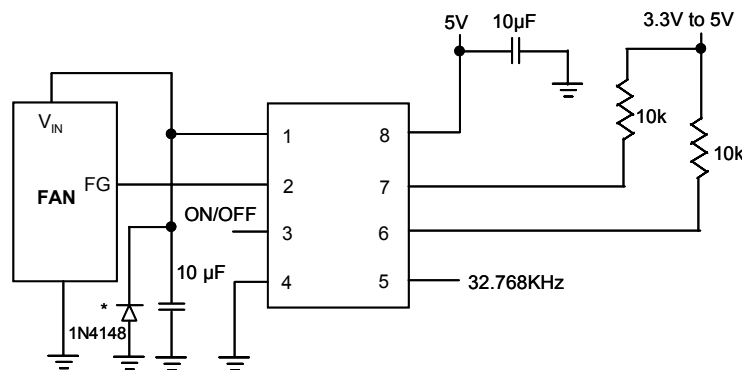

Diode 1N4148 is optional

Block Diagram

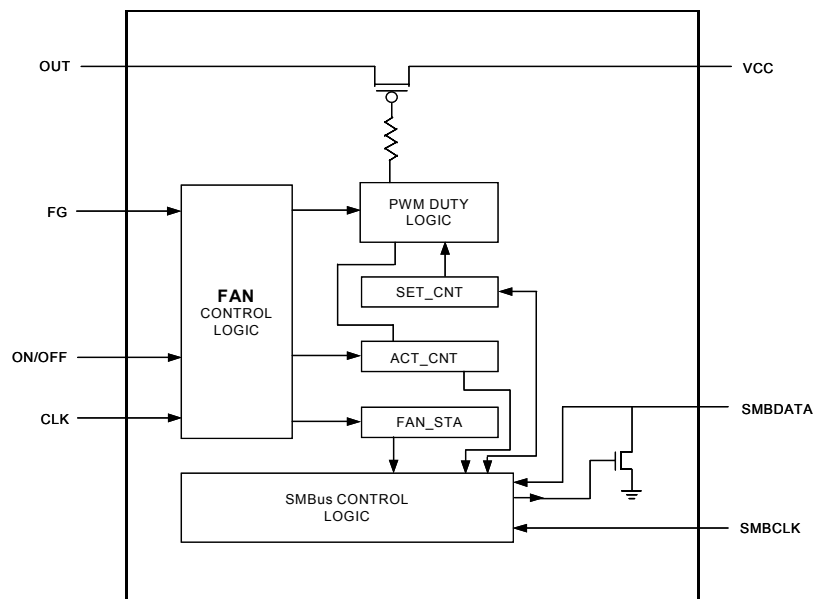

Pin Description

PIN NO.	PIN NAME	PIN FUNCTION
1	OUT	PWM output, connect to fan
2	F.G.	FAN pulse Input
3	ON/OFF	ON/OFF control pin, 0V means shutdown
4	GND	Ground
5	CLK	Clock input for fan speed measurement
6	SMBCLK	SMBus clock line
7	SMBDATA	SMBus data line
8	V _{CC}	Supply voltage

Description

The fan speed is measured by counting the number of the CLK pin period between the rising edges of two fan speed pulses on FG pin. In this way, we are actually measuring the period of the fan speed. To avoid the cost of doing division to obtain the speed, this count number, N, is used in the PWM control algorithm, thus, the desired fan speed should be programmed by writing the corresponding count number. The count number is given by:

$$N = (\text{CLK} \times 30) / (\text{rpm} \times P)$$

N : Count Number

P : FG pulses number per revolution of fan.

For CLK = 32768Hz, P = 2

$$\Rightarrow N = 491520 / \text{rpm}$$

For CLK = 16384Hz, P = 2

$$\Rightarrow N = 245762 / \text{rpm}$$

Some selected count numbers are shown below

Table 1. Count numbers for P=2

rpm	CLK=32768Hz	CLK=16384Hz
968	---	254
1935	254	127
2000	246	123
3000	164	82
4000	123	61
5000	98	49
6000	82	41
7000	70	35
8000	61	31
9000	55	27
10000	49	25
20000	25	12
30000	16	8

When pin 3 (On/Off) is a logical 1, the fan speed will be controlled according to the setting in the programmed fan speed register. There are two ways to stop the fan, (1) setting pin 3 (On/Off) to 0V, (2) program the fan speed register to 255. These also makes the fan controller into power saving mode.

Controlling Fan at Lower Speed

For stably controlling fans at lower rotation speed, three schemes are recommended as below:

1. Use larger decoupling capacitors between FAN_OUT and GND.
2. Shunt a capacitor of 1μF-2μF on FG pin to GND.
3. Use fans with open-collector FG outputs.

When controlling fans under lower rotation speed, the output voltage of FAN_OUT would be too low for fan to generate recognizable FG signals.

Using decouple capacitors on FAN_OUT and FG is to increase the SNR on FG pins. While using fans with open_collector FG outputs can thoroughly solve the problem, because the logic high level of FG would be fixed to 5V.

Internal Registers

This IC provides 3 SMBus registers.

1. Programmed fan speed register: (SET_CNT, address: 00b)

This register is a read/write register, it contains the count number of the desired fan speed. Power up default is FFh.

2. Actual fan speed register: (ACT_CNT, address: 01b)

This register is read only. It contains the count number of

the actual fan speed. Power up default is FFh.

3. Fan status register: (FAN_STA, address: 10b)

This register is read only. Its bit 0 is set to 1 when the actual fan speed is $\pm 20\%$ outside the desired speed. Its bit 1 is set to 1 when fan speed is below

1920 rpm. Power up default is 10b.

SMBus Address

The SMBus address of this chip is fixed to 7Ch (01111100b) for write and 7Dh(01111101b) for read.

SMBus Timing

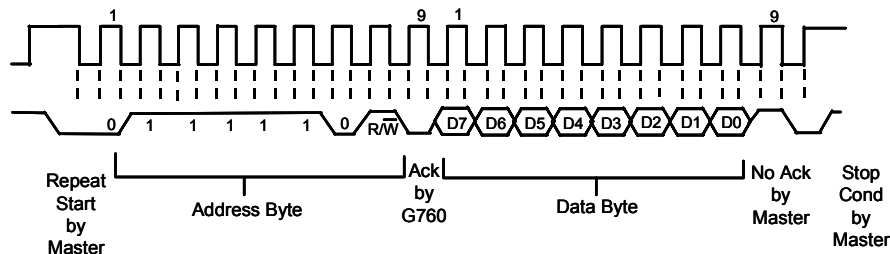
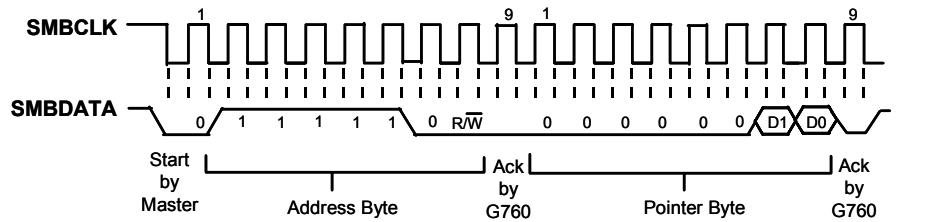

(a) Typical Pointer Set Followed by Immediate Read

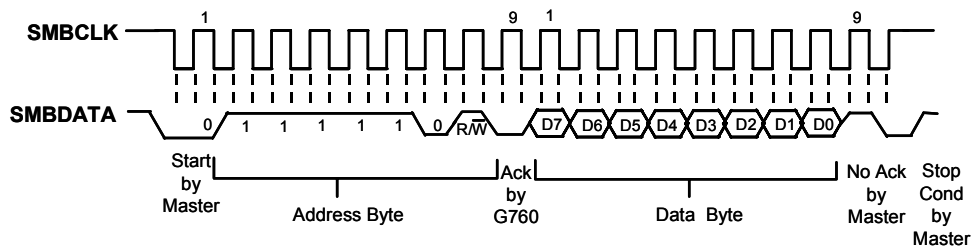

(b) Typical 1-Byte Read with Preset Pointer

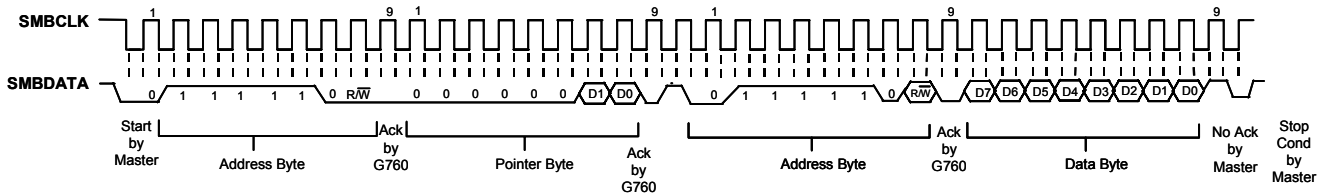

(a) Typical Pointer Set Followed by Immediate Read

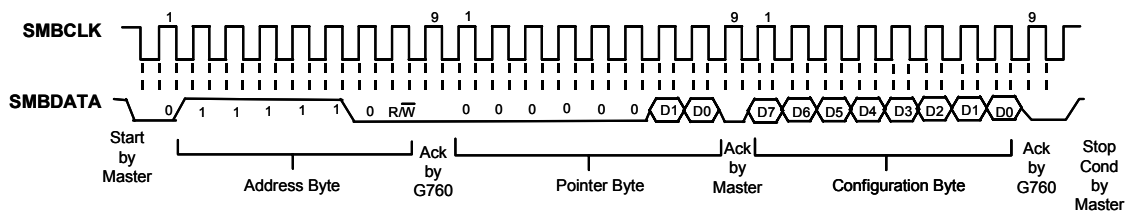

(b) Register Write

Package Information

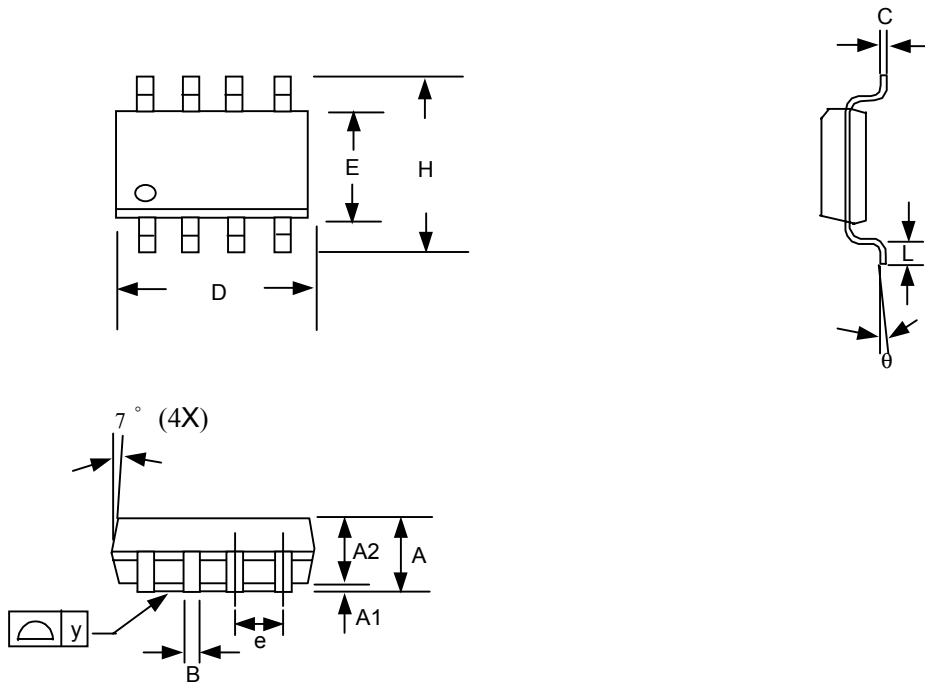

Note:

1. Package body sizes exclude mold flash and gate burrs
2. Dimension L is measured in gage plane
3. Tolerance 0.10mm unless otherwise specified
4. Controlling dimension is millimeter converted inch dimensions are not necessarily exact.

SYMBOL	DIMENSION IN MM			DIMENSION IN INCH		
	MIN.	NOM.	MAX.	MIN.	NOM.	MAX.
A	1.35	1.60	1.75	0.053	0.063	0.069
A1	0.10	----	0.25	0.004	----	0.010
A2	----	1.45	----	----	0.057	----
B	0.33	----	0.51	0.013	----	0.020
C	0.19	----	0.25	0.007	----	0.010
D	4.80	----	5.00	0.189	----	0.197
E	3.80	----	4.00	0.150	----	0.157
e	----	1.27	----	----	0.050	----
H	5.80	----	6.20	0.228	----	0.244
L	0.40	----	1.27	0.016	----	0.050
y	----	----	0.10	----	----	0.004
θ	0°	----	8°	0°	----	8°

Taping Specification

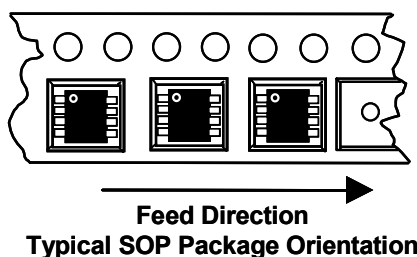

GMT Inc. does not assume any responsibility for use of any circuitry described, no circuit patent licenses are implied and GMT Inc. reserves the right at any time without notice to change said circuitry and specifications.