

GBU 10A/15A/25A/35A SERIES

SILICON BRIDGE RECTIFIERS
GLASS PASSIVATED
BRIDGE RECTIFIERS

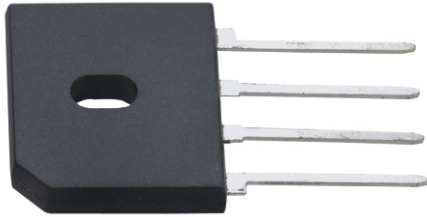

FEATURES

- Surge overload rating-175 amperes peak
- Ideal for printed circuit board
- Reliable low cost construction utilizing molded plastic technique
- Plastic material has Underwriters Laboratory Flammability classification 94V-O
- Mounting Position: Any

REVERSE VOLTAGE -50 to 1000 Volts
FORWARD CURRENT -8.0 Amperes

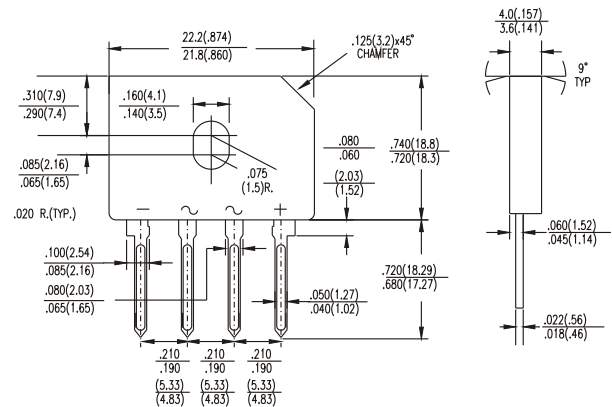

Dimensions in inches and (millimeters)

MAXIMUM RATINGS AND ELECTRICAL CHARACTERISTICS

Ratings at 25°C ambient temperature unless otherwise specified.
Single phase, half wave, 60Hz, resistive or inductive load.
For capacitive load, derate current by 20%.

CHARACTERISTICS	SYMBOL	GBU	GBU	GBU	GBU	GBU	GBU	GBU	UNITS
		10005	1001	1002	1004	1006	1008	1010	
		15005	1501	1502	1504	1506	1508	1510	
		25005	2501	2502	2504	2506	2508	2510	
		35005	3501	3502	3504	3506	3508	3510	
Maximum Recurrent Peak Reverse Voltage	V_{RRM}	50	100	200	400	600	800	1000	V
Maximum RMS Voltage	V_{RMS}	35	70	140	280	420	560	700	V
Maximum DC Blocking Voltage	V_{DC}	50	100	200	400	600	800	1000	V
Maximum Average Forward (with heatsink Note 2) Rectified Current @ $T_C=100^\circ\text{C}$ (without heatsink)	$I_{(AV)}$	10/15/25/35 3.6							A
Peak Forward Surge Current 8.3 ms single half sine-wave super imposed on rated load (JEDEC Method)	I_{FSM}	240 240 350 400							A
Maximum Forward Voltage at 5.0/7.5/12.5/17.5A DC	V_F	1.0							V
Maximum DC Reverse Current @ $T_J=25^\circ\text{C}$ at Rated DC Blocking Voltage @ $T_J=125^\circ\text{C}$	I_R	5.0 500							μA
$I^2 t$ Rating for fusing ($t < 8.3\text{ms}$)	$I^2 t$	200							A^2S
Typical Junction Capacitance per element (Note 1)	C_J	70							pF
Typical Thermal Resistance (Note 2)	$R_{\theta JC}$	2.2							$^\circ\text{C/W}$
Operating Temperature Range	T_J	-40 to +125							$^\circ\text{C}$
Storage Temperature Range	T_{STG}	-40 to +125							$^\circ\text{C}$

NOTES: 1. Measured at 1.0MHz and applied reverse voltage of 4.0V DC.
2. Device mounted on 100mm x 100mm X 1.6mm Cu Plate Heatsink.

GBU 10A/15A/25A/35A SERIES

SILICON BRIDGE RECTIFIERS
GLASS PASSIVATED
BRIDGE RECTIFIERS



RATING AND CHARACTERISTICS CURVES GBU 10A/15A/25A/35A SERIES

FIG. 1 - MAXIMUM FORWARD SURGE CURRENT

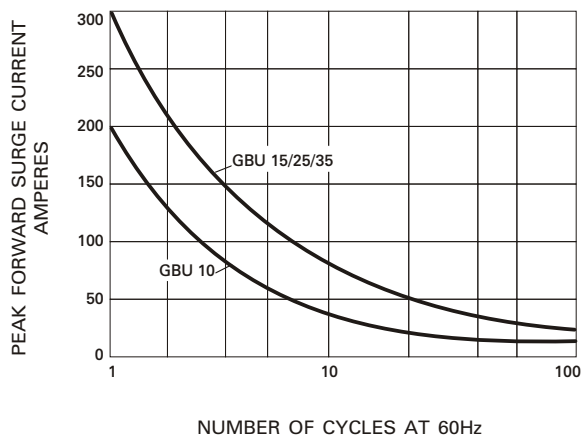

FIG. 2 - DERATING CURVE
OUTPUT RECTIFIED CURRENT

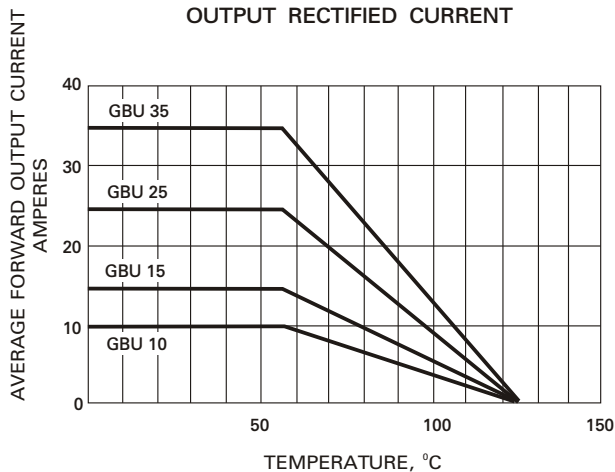

FIG. 3 - TYPICAL FORWARD
CHARACTERISTICS

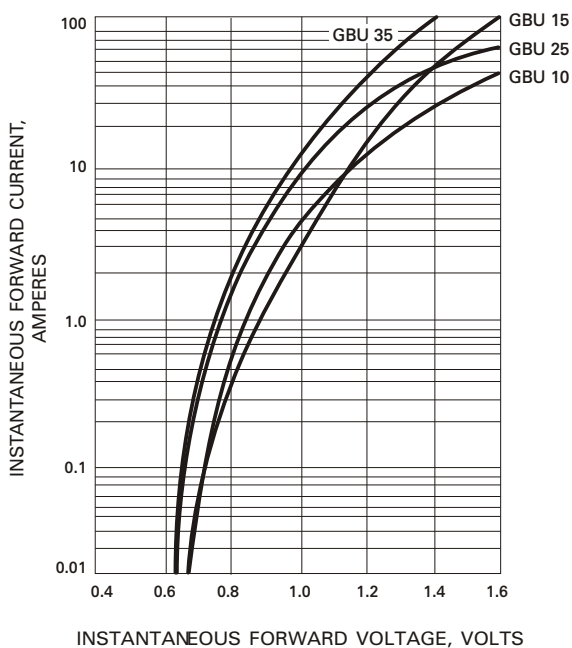

FIG. 4- TYPICAL REVERSE
CHARACTERISTICS

