

GL496

High Speed Infrared Emitting Diode

■ Features

1. High speed response (response frequency : 40MHz)
2. Peak emission wavelength λ_p : TYP. 880 nm
3. Half intensity angle $\Delta\theta$: $\pm 22^\circ$
4. Lead bending type may be used.

■ Applications

1. AV equipment
2. Personal computers
3. Portable information terminal equipment

■ Outline Dimensions

(Unit : mm)

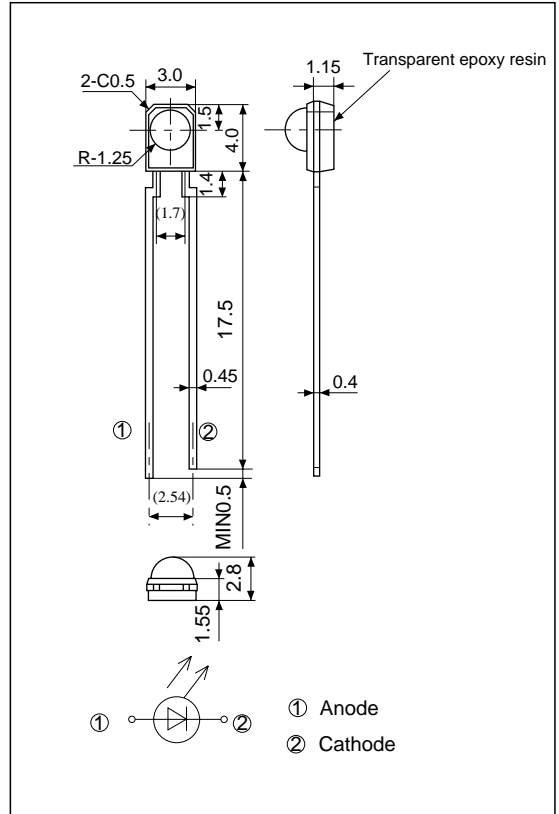

■ Absolute Maximum Ratings

(Ta=25°C)

Parameter	Symbol	Rating	Unit
Forward current	I_F	50	mA
*1 Peak forward current	I_{FM}	0.5	A
Reverse voltage	V_R	4	V
Power dissipation	P	87.5	mW
Operating temperature	T_{opr}	- 25 to + 85	°C
Storage temperature	T_{stg}	- 40 to + 90	°C
*2 Soldering temperature	T_{sol}	260	°C

*1 Pulse width 100 μ s, Duty ratio=0.01

*2 For MAX. 5 seconds at the position of 1.4 mm from the resin edge

■ Electro-optical Characteristics

(Ta=25 °C)

Parameter	Symbol	Conditions	MIN.	TYP.	MAX.	Unit
Forward voltage	V_F	$I_F = 50\text{mA}$	-	1.55	1.75	V
Peak forward voltage	V_{FM}	$I_{FM} = 0.5\text{A}$	-	2.6	3.6	V
Reverse current	I_R	$V_R = 3\text{V}$	-	-	10	μA
^{*3} Radiant intensity	I_E	$I_F = 50\text{mA}$	3.0	10.0	-	mW/sr
Radiant flux	Φ_E	$I_F = 50\text{mA}$	-	12	-	mW
Peak emission wavelength	λ_p	$I_F = 50\text{mA}$	850	880	900	nm
Half intensity wavelength	$\Delta \lambda$	$I_F = 50\text{mA}$	-	50	-	nm
Terminal capacitance	C t	$V_R = 0\text{V}, f = 1\text{MHz}$	-	60	-	pF
^{*4} Response frequency	f c	$I_F = 50\text{mA} + 10\text{mA}_{p-p}$	-	40	-	MHz
Half intensity angle	$\Delta \theta$	$I_F = 50\text{mA}$	-	± 22	-	°

^{*3} Value obtained by converting the value in power of radiant fluxes emitted at the solid angle of 0.01 sr (steradian) in the direction of mechanical axis of the lens portion into 1 sr or all those emitted from the light emitting diode.

^{*4} Frequency to bring about -3dB reduction of modulated radiant intensity from 100kHz

Fig. 1 Forward Current vs. Ambient Temperature

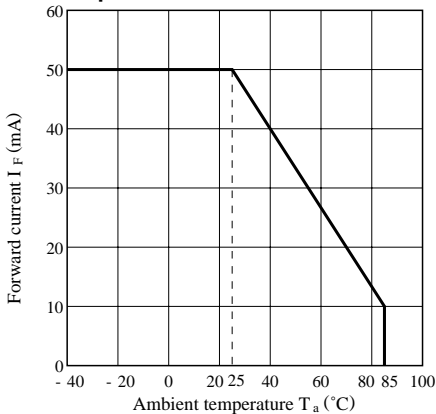

Fig. 2 Peak Forward Current vs. Duty Ratio

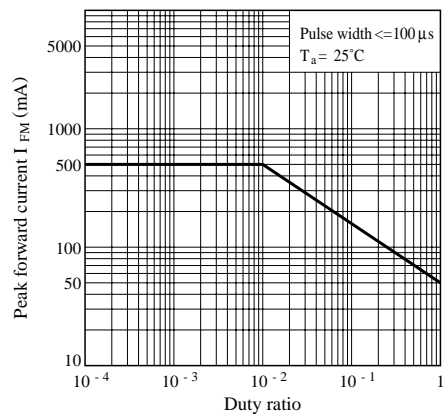

Fig. 3 Spectral Distribution

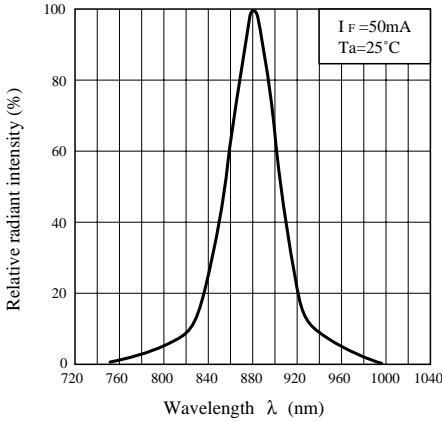

Fig. 4 Peak Emission Wavelength vs. Ambient Temperature

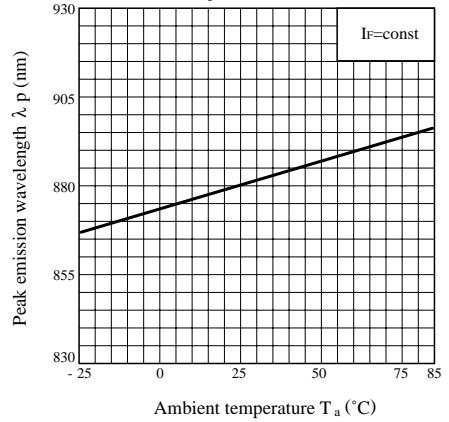

Fig. 5 Forward Current vs. Forward Voltage

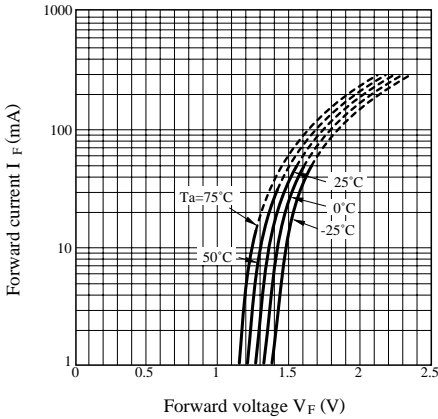

Fig. 6 Relative Radiant Flux vs. Ambient Temperature

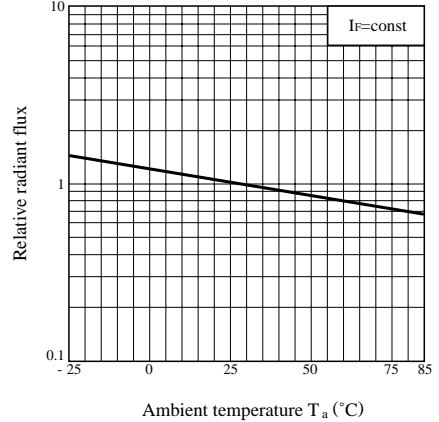

Fig. 7 Radiant Intensity vs. Forward Current

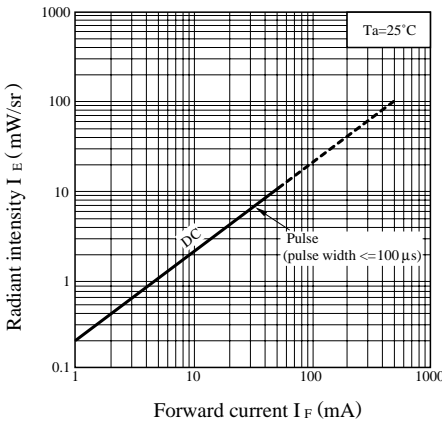

Fig. 8 Relative Radiant Intensity vs. Distance

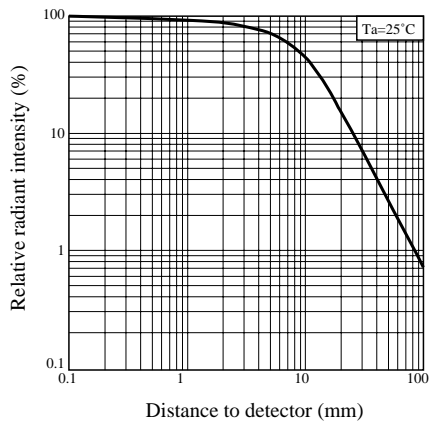

Fig. 9 Relative Radiant Intensity vs. Frequency

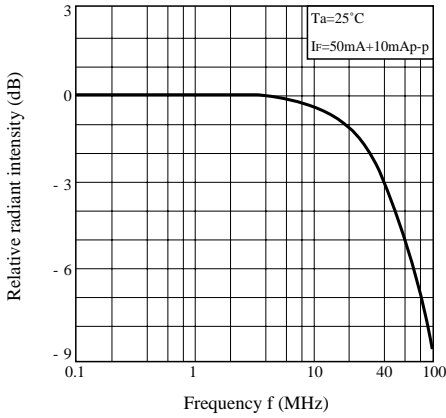

Fig. 10 Relative Collector Current vs. Distance
(Detector : PT414PI)

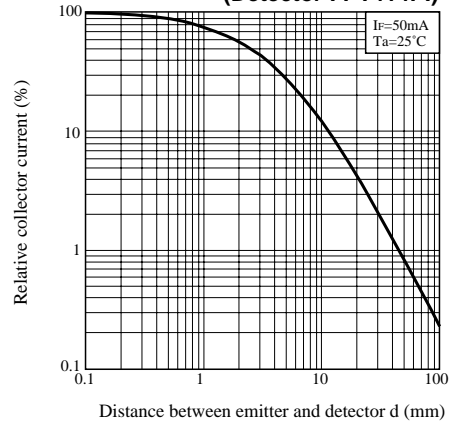
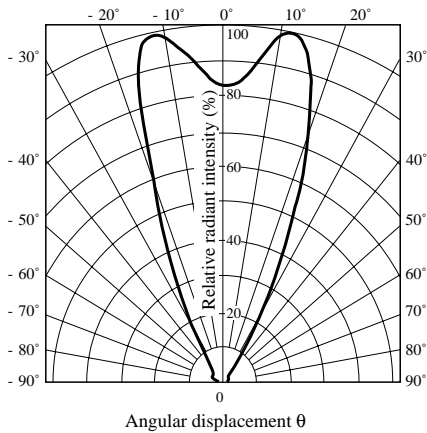

Fig. 11 Radiation Diagram (Ta = 25°C)



● Please refer to the chapter "Precautions for Use". (Page 78 to 93)