

GP2W2002YK

IrDA Control Infrared Transceiver
for Peripheral Type 2

Revision 1.0.1

November 26, 1998

SHARP CORPORATION

Record of Modification and Revision

Version	Issue Date	Comments
0.9	August 18th, 1998	First Edition
0.91	August 25th, 1998	Outline Dimension and Absolute Maximum Ratings Modified
1.0	October 23rd,1998	Absolute Ratings and Electrical Characteristics Modified
1.0.1	November 26th,1998	Electrical and Optical Specifications Modified

(Preliminary Information Disclaimer)

This document includes a "Preliminary Information" of Sharp IrDA Control Infrared Transceiver (for IrDA Control Peripheral Type 2). Any of information under this document, such as Specifications and outline dimensions, are applicable only for reference purpose, and Sharp hold all rights to change or alter prices at any time without notice.

In absence of confirmation by device Specification Sheets, SHARP takes no responsibility for any defects that occur in equipment using any of SHARP's device, shown in catalogues, data books, Preliminary Information, etc. Contact SHARP, or SHARP local representatives in order to obtain the latest version of the device Specification Sheets before using any SHARP's devices.

Table Of Contents

1. DESCRIPTION 4

2. IRDA CONTROL INFRARED TRANSCEIVER INTERNAL BLOCK DIAGRAM 4

3. PACKAGE OUTLINE DIMENSIONS (TENTATIVE)..... 5

4. ABSOLUTE MAXIMUM RATINGS..... 5

5. RECOMMENDED OPERATING CONDITIONS 6

6. ELECTRICAL AND OPTICAL SPECIFICATIONS 7

7. PINOUT 8

8. APPLICATION CIRCUIT AND RECOMMENDED COMPONENTS..... 9

9. WAVEFORM EXAMPLES 9

10. RESET FUNCTION..... 10

11. THE DERATING CURVE OF PEAK FORWARD LED CURRENT 10

IrDA Control Infrared Transceiver (for Peripheral Type 2)

GP2W2002YK Technical Data

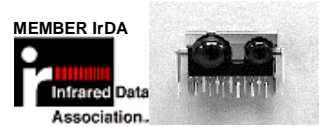

1. Description

The Sharp IrDA Control Infrared Transceiver provides the wireless interface between logic and IR signals for through-air, serial, half-duplex IrDA Control data links and is designed to satisfy the IrDA Control Physical Layer Specifications for Peripheral Type 2. The GP2W2002YK is a low power operatable integrated

infrared transceiver that contains an IRLED, a LED driver circuit, a PIN photodiode, an excellent sensitivity receiver, and an envelope detector. The transceiver also contains some additional functions, such as shut down and sensitivity recovery for low current consumption and longer communication distance.

<Features>

- ⦿ Meets IrDA Control (for Peripheral Type 2)
- ⦿ Wide Viewing Angle ([Min.] 1.5 m @ +/-40°)
- ⦿ Wireless Communication at 75kbps data rate
- ⦿ Low Power Operation - at 3.3V
- ⦿ Built-in Envelope Detector
- ⦿ RESET Function to Recover the Receiver Sensitivity
- ⦿ Optimized Interface to Sharp Peripheral Engine, an embedded communication controller for IrDA Control.

2. IrDA Control Infrared Transceiver Internal Block Diagram

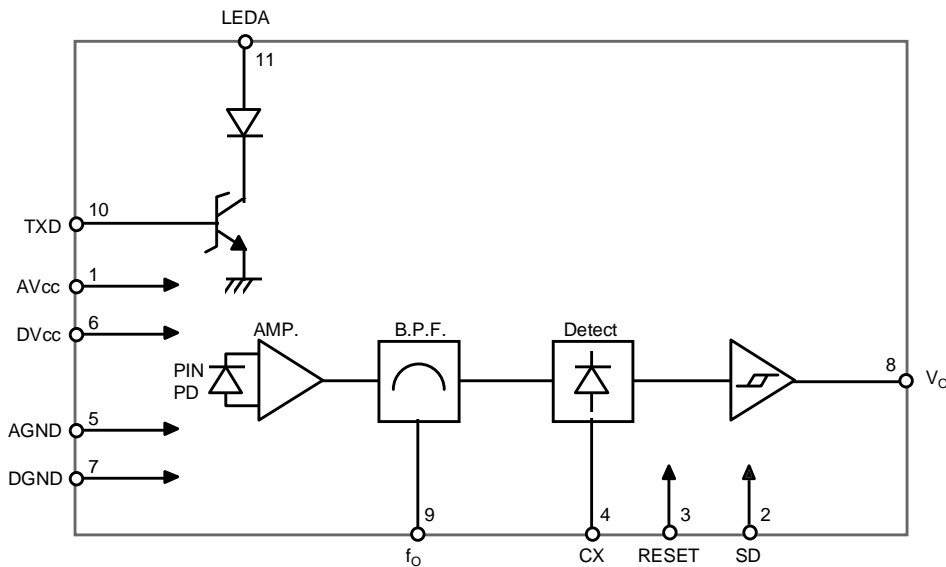
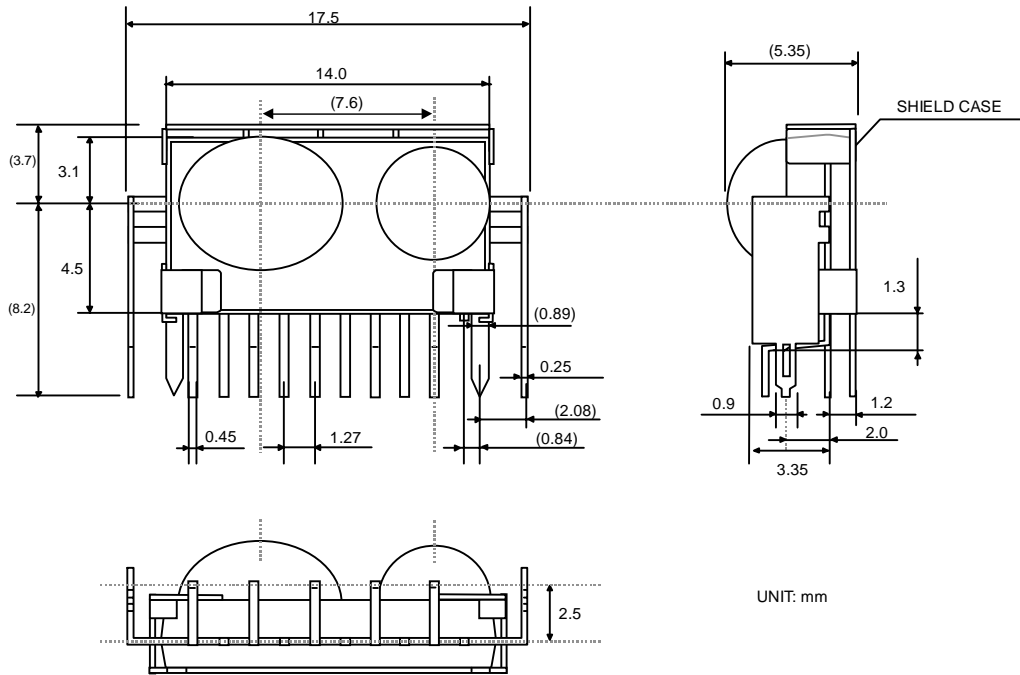

Figure 2.1 GP2W2002YK Internal Block Diagram

3. Package Outline Dimensions (TENTATIVE)



1. Unspecified tolerance shall be ± 0.3 (mm).
2. Resin burr shall not be included in outline dimensions.
3. Package Material : Visible Light Cut-off Resin (Color: Black)
4. Pin Assignment : See "Pinout" for details.
5. Lead pitch distance represents that of the lead root.
6. The appearance of the shielded case is TENTATIVE, and is subject to change without notice.

4. Absolute Maximum Ratings

Parameter	Symbol	Min.	Max.	Units	Conditions
Supply Voltage	V_{CC}	0	6.0	V	
Operating Temperature	T_{OP}	-10	70	$^{\circ}C$	
Storage Temperature	T_{ST}	-20	85	$^{\circ}C$	
Average Forward LED Current	I_{FD} (DC)	-	60	mA	
Peak Forward LED Current	I_{FM}	-	600	mA	*1
Transmitter Data Input Current	I_{TXD}	-	5.0	mA	
Receiver Data Output Voltage	V_O	-	V_{CC}	V	
Soldering Temperature	T_{SOL}	-	260	$^{\circ}C$	*2, For 5s

(NOTES)

1. The derating curve of peak forward current vs. ambient temperature is shown in section 11, figure 11.1.
2. The soldering should be done at the distance from 1.3mm from the resin edge of the transceiver module.

5. Recommended Operating Conditions

Parameter	Symbol	Min.	Max.	Units	Conditions
Operating Temperature	T_{OP}	-10	70	°C	
Supply Voltage	V_{CC1}	2.7	5.5	V	Supply voltage for receiver side
Supply Voltage	V_{CC2}	4.25	5.25	V	Supply voltage for emitter side
Transmitter Input Subcarrier Frequency	fsc	1.484	1.517	MHz	^{*3} Frequency accuracy within the range of $\pm 1.1\%$
Logic High Transmitter Input Voltage (TXD)	$V_{IH(TXD)}$	2.7	-	V	
Logic Low Transmitter Input Voltage (TXD)	$V_{IL(TXD)}$	0.0	0.3	V	
Logic High Receiver Input Irradiance	E_{IL}	3.0	1250	$\mu W/cm^2$	^{*4} $\Theta_r \leq \pm 40^\circ$, $\Phi_r \leq \pm 25^\circ$ ^{*5} For in-band signals $\leq 75.83kb/s$
LED (Logic High) Current Pulse Amplitude	I_{LEDA}	400	-	mA	$I_E=9mW/sr$, ^{*4} $\Theta_t \leq \pm 40^\circ$, $\Phi_t \leq \pm 25^\circ$
Receiver Signal Rate	D_{RATE}	74.175	75.825	kb/s	
High Level Input Voltage (RESET Terminal)	V_{IHRE}	2.1	Vcc	V	Refer to "RESET Function"
Low Level Input Voltage (RESET Terminal)	V_{ILRE}	0	0.6	V	Refer to "RESET Function"
Recovery Time	tret	-	40	μsec	
SD Recovery Time	t_{SD}	-	1	msec	
High Level Input Voltage (SD Terminal)	V_{IHSD}	2.2	Vcc	V	
Low Level Input Voltage (SD Terminal)	V_{ILSD}	0	0.5	V	
Input Current (TX Terminal)	I_{TX}	2.3	2.6	mA	$V_{IH(TXD)}=2.7V$

[NOTES]:

- IrDA Control system uses 16PSM coding scheme over 1.5MHz sub-carrier. See IrDA Control Physical Layer Link Specification for the details of coding scheme and pulse characteristics.
- See Figure 5.1 (below) for the viewing angle definition.
- An in-band optical signal is a pulse/sequence where the peak wavelength λ_p , is defined as $850nm \leq \lambda_p \leq 900nm$, and the pulse characteristics are compliant with the IrDA Control Physical Layer Link Specification.

(): TENTATIVE Value

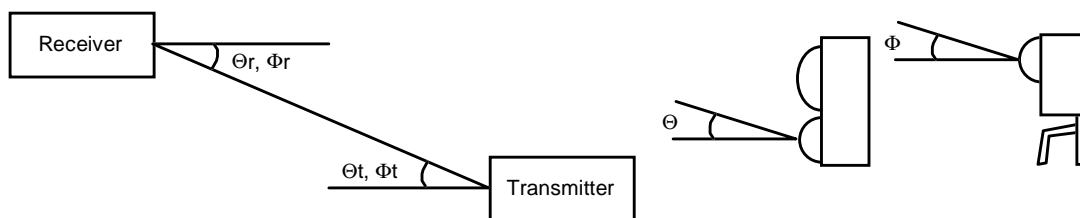

Θ : Horizontal (X-Axis)
 Φ : Vertical Angle (Y-Axis)

Figure 5.1 IrDA Control Transceiver Viewing Angle Criteria

6. Electrical and Optical Specifications

(Unspecified Ta=25 °C, Vcc=3.3V)

Parameter	Symbol	Min.	Typ.	Max.	Units	Conditions	
RECEIVER SIDE							
Current Dissipation	I _{CC}	-	5.0	7.0	mA	No input IR signal, V _{CC} =3.3V	
S/D Current Dissipation	I _{ccsd}	-	7.0	10.0	μA	*6 at low current consumption mode	
Receiver Data Output Voltage	Logic High	V _{OH}	V _{CC} -0.5	-	-	V	No input IR signal, High level
	Logic Low	V _{OL}	-	-	0.5	V	I _{OL} =400μA
Pulse Width	Single Pulse	t _{w,s}	3.66	6.67	9.67	μsec	*8,9 Input pulse width 6.33μs
	Double Pulse	t _{w,d}	10.33	13.33	16.34	μsec	*8,9 Input pulse width 13.0μs
	Multi Pulse	t _{w,m}	50.36	53.36	56.36	μsec	*8,9 Input pulse width 53.00μs,*
Jitter	t _j	-1.8	-	+1.8	μsec	*7,8	
Receiver Data Output Rise Time	t _r	-	-	6.0	μsec	*8	
Receiver Data Output Fall Time	t _f	-	-	6.0	μsec	*8	
Receiver Detecting Distance	L	1.5	-	-	m	*4 Θ _r ≤ 40°, Φ _r ≤ 25° 68mW/sr	
TRANSMITTER SIDE							
Transmitter Radiant Intensity	I _E	9	-	-	mW/sr	*4 Θ _t ≤ ±40°, Φ _t ≤ ±25° I _{LED} =400mA	
Peak Wavelength	λ _p	850	-	900	nm	I _{LED} =400mA	
Rise Time	t _{r (LED)}	-	-	80	nsec	*9,10	
Fall Time	t _{f (LED)}	-	-	80	nsec	*9,10	

(NOTES)

* t_{w,m}=53.00 μs (6.67 μs×8-0.36)

6. "L": Low current consumption mode, "H" or OPEN: Normal operating mode.

7. The time difference or time gap from the pulse judgement criteria point of the output waveform at the 50% point between V_{OH} and V_{OL}.

8. Receiver output wavelength definition:

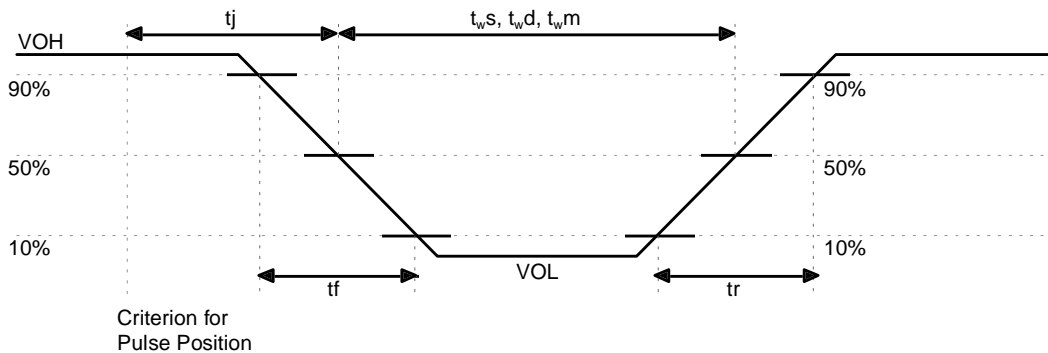

Figure 6.1 GP2W2002YK Receiver Output Waveform

9: Emitter output wavelength definition:

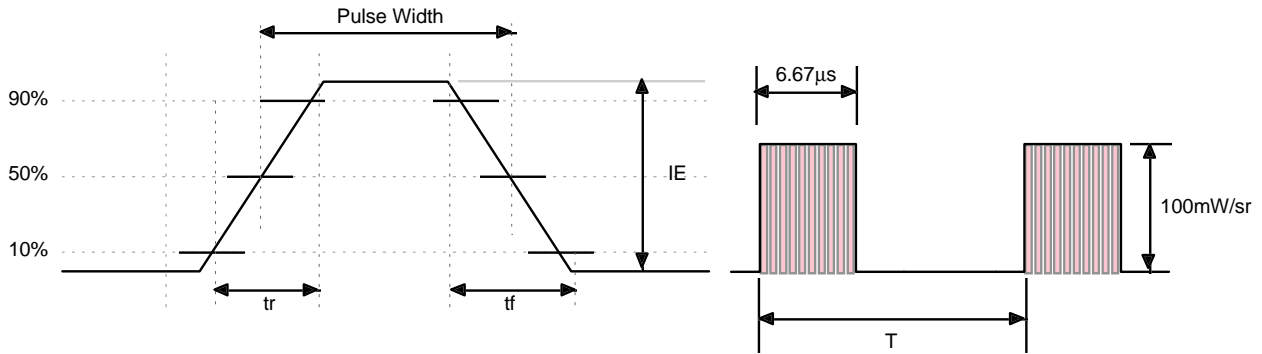
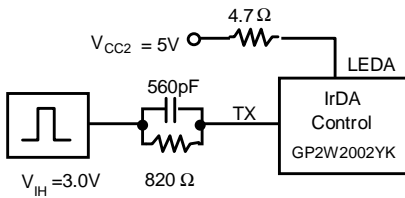

Figure 6.2 GP2W2002YK Emitter Output Waveform

10: Recommended Circuit for Emitter Side:



The output signal shown above (Figure 6.2) should be obtained by applying the “recommended circuit for emitter side” shown right.

7. Pinout

Pin	Description	Symbol
1	Analog Supply Voltage	AV_{CC}
2	Shut Down for Low Current Consumption	SD
3	RESET Terminal for Receiver Sensitivity Recovery	RESET
4	-	CX
5	Analog Ground	AGND
6	Digital Supply Voltage	DV_{CC}
7	Digital Ground	DGND
8	Receiver Data Output	V_o
9	Bandpass Filter	f_0
10	Transmitter Data Input	TXD
11	IRLED Anode	LEDA

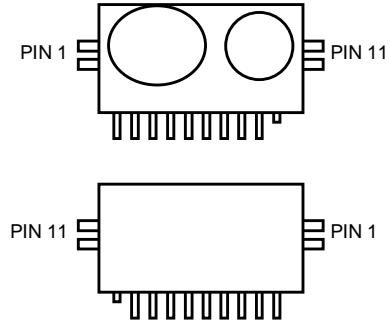

8. Application Circuit and Recommended Components

Parts	Recommended Value
CX1	470pF, ± 10%, Ceramic
CX2	0.1µF, ± 10%, Ceramic
CX3	4.7µF, ± 20%, Aluminum
CX4	0.1µF, ± 10%, Ceramic
CX5	560pF, ± 10%, Ceramic
R1	10Ω, ± 5%, 0.125 Watt
R2	8.2kΩ, ± 1%, 0.125 Watt
R3	820 Ω, ± 5%, 0.125 Watt
R4	4.7Ω, ± 5%, 0.5 Watt

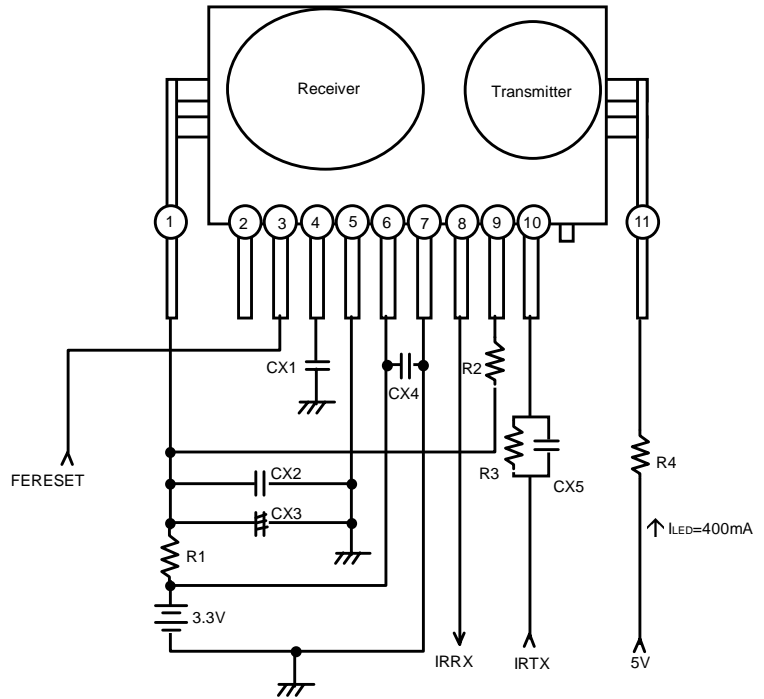

Figure 8.1 GP2W2002YK Application Circuit Example

9. Waveform Examples

The following diagram shows an example of IrDA Control implementation using Sharp IrDA Control Infrared Transceiver. The waveform of the implemented system with Sharp IrDA Control Infrared Transceiver will be as shown below:

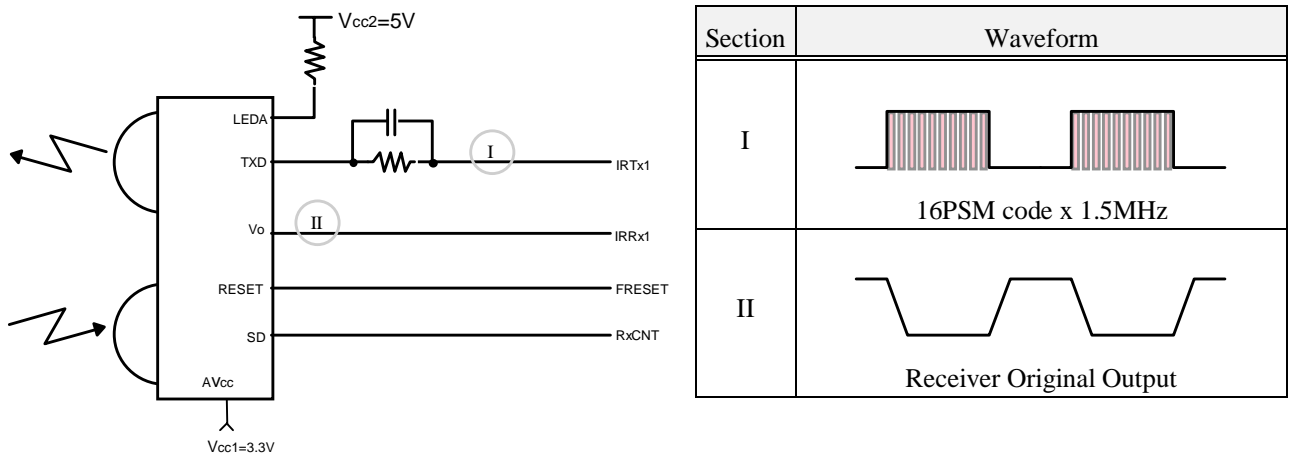
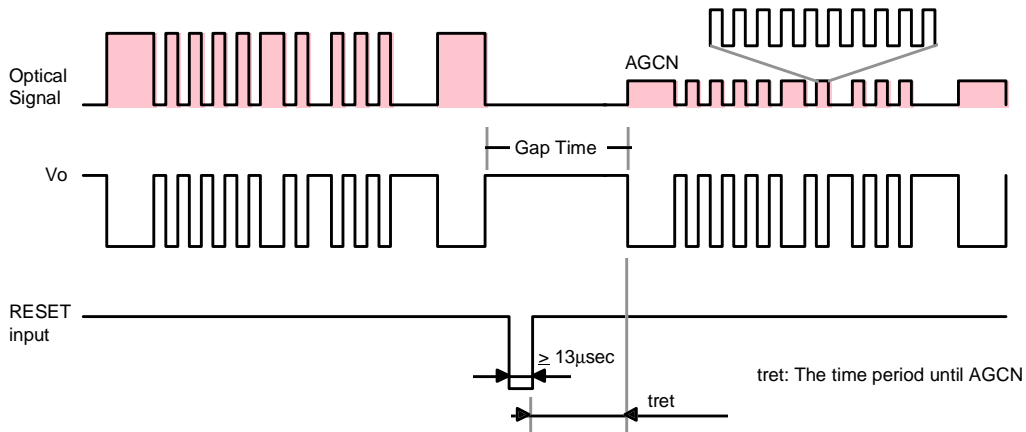

Figure 9.1 IrDA Control Transceiver Implementation

10. RESET Function

The “RESET” terminal is used to recover the receiver sensitivity to its maximum level. Since Sharp IrDA Control Infrared Transceiver has a built-in capability to adjust the receiving sensitivity, as a result, a very weak IR signals may not be correctly received just after receiving a very strong IR signals.

Following figure shows an example of “RESET” signal in order to recover the Sharp IrDA Control Infrared Transceiver’s receiving sensitivity to its receiving sensitivity to its maximum level:



(NOTES)

This pinout is an Active Low terminal, and stays HIGH level when it is OPEN. The Low Level Pulse for the period of $\geq 13\mu\text{sec}$ enables this function to work. This $\geq 13\mu\text{sec}$ input must be pulsed within the period of Gap time in order for the transceiver to have receiver sensitivity recovery. The timing for this “RESET” pulse should be adjusted at controller side.

11. The Derating Curve of Peak Forward LED Current

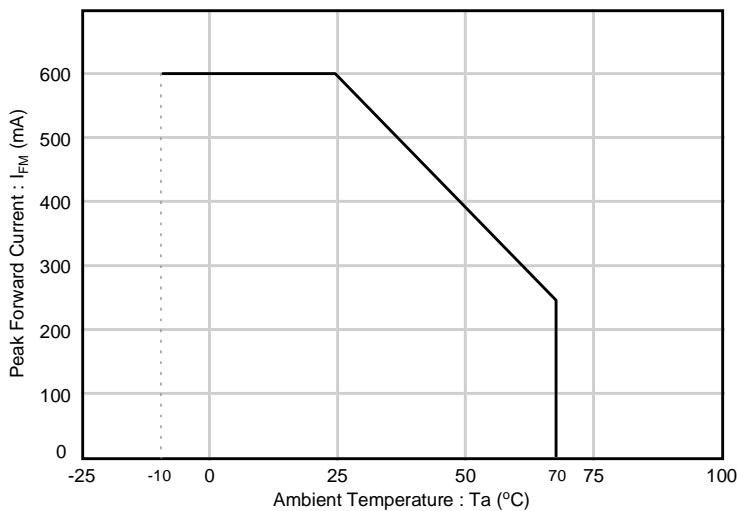

Pulse width $\leq 3.3\mu\text{sec}$, Duty Ratio $\leq 25\%$

Figure 11.1 Derating Curve of Peak LED Current

LIFE SUPPORT POLICY

SHARP components should not be used in medical devices with life support functions or in safety equipment (or similar applications where component failure result in loss of life or physical harm) without the written approval of an officer of the SHARP Corporation.

SHARP reserves the right to make changes in specifications at any time and without notice. SHARP does not assume any responsibility for the use of any circuitry described; no circuit patent licenses are implied.

SHARP

SHARP CORPORATION Japan
INTERNATIONAL SALES & MARKETING GROUP
-IC/ELECTRONIC COMPONENTS
22-22 Nagaïke-cho, Abeno-ku, OSAKA, 545, JAPAN
PHONE: (81) 6-621-1221
FAX: (81) 6-624-0163

NORTH / SOUTH AMERICA:
SHARP MICROELECTROICS OF AMERICAS
5700 Northwest, Pacific Rim Boulevard#20
Camas, WA, 98607, U.S.A.
PHONE: (1) 360-834-2500
FAX: (1) 360-834-8903

EUROPE:
SHARP ELECTRONICS (EUROPE) GmbH
Microelectronics Division
Sonninstrasse 3, 20097 Hamburg, Germany
PHONE: (49) 40-2376-2286
FAX: (49) 40-2376-2232

TAIWAN:
**SHARP ELECTRONIC COMPONENTS (TAIWAN)
CORPORATION**
8 Fl., No. 16, Sec 4, Nanking E Rd.,
Taipei, Taiwan, Republic of China
PHONE: (886) 2-577-7341
FAX: (886) 2-577-7326 / 2-577-7328

HONG KONG
SHARP - ROXY (HONG KONG) LTD.
3rd Business Division,
Room 1701 - 1711, Admiralty Centre Tower 1,
Harcourt Road, Hong Kong
PHONE: (852) 28229311
FAX: (852) 28660779

SINGAPORE:
SHARP ELECTRONICS (SINGAPORE) PTE., LTD.
438A, Alexandra Road, #05-01/02,
Alexandra Technopark, Singapore 119967
PHONE: (65) 271-3566
FAX: (65) 271-3855

KOREA:
**SHARP ELECTRONIC COMPONENTS (KOREA)
CORPORATION**
RM 501 Geosung B/D.
541, Dohwa-dong, Mapo-ku, Seoul, Korea
PHONE: (82) 2-711-5813 ~ 8
FAX: (82) 2-711-5819