

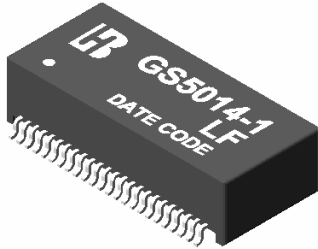

# 1000 BASE -T DUAL PORT MAGNETICS MODULES

## P/N: GS5014-1 LF DATA SHEET

### Feature



- Designed for Ethernet 100/1000 BASE-T, full duplex applications.
- Supports 8 pairs of category 5 UTP cable.
- Cable interface for isolation and low common mode emissions.
- Compliant with IEEE 802.3ab standard for 1000 BASE-T.
- Comply with RoHS requirements-whole part No Cd, No Hg, No Cr6+, No PBB and PBDE and No Pb on external pins.
- Comply with Air reflow profile of JEDEC 020C.
- Operating temperature range: 0 to +70 .
- Storage temperature range: -25 to +125 .

### Electrical Specifications @ 25°C

Part Number	Turns Ratio (±5%)		OCL (uH Min) @100KHz/0.1V with 8mA DC Bias	Cross talk Attenuation (dB Min)			HI-POT (Vrms)
	TX	RX		30MHz	60MHz	100MHz	
GS5014-1 LF	1CT:1CT	1CT:1CT	350	-40	-35	-30	1500

### Continue

Part Number	Insertion Loss (dB Max)	Return Loss (dB Min)@ Load 100					DCMR (dB Min)		
		1-100MHz	1-30MHz	40MHz	50MHz	60-80MHz	100MHz	30MHz	60MHz
GS5014-1 LF	-0.9	-16	-14	-12.5	-12	-10	-43	-37	-33

### Schematic

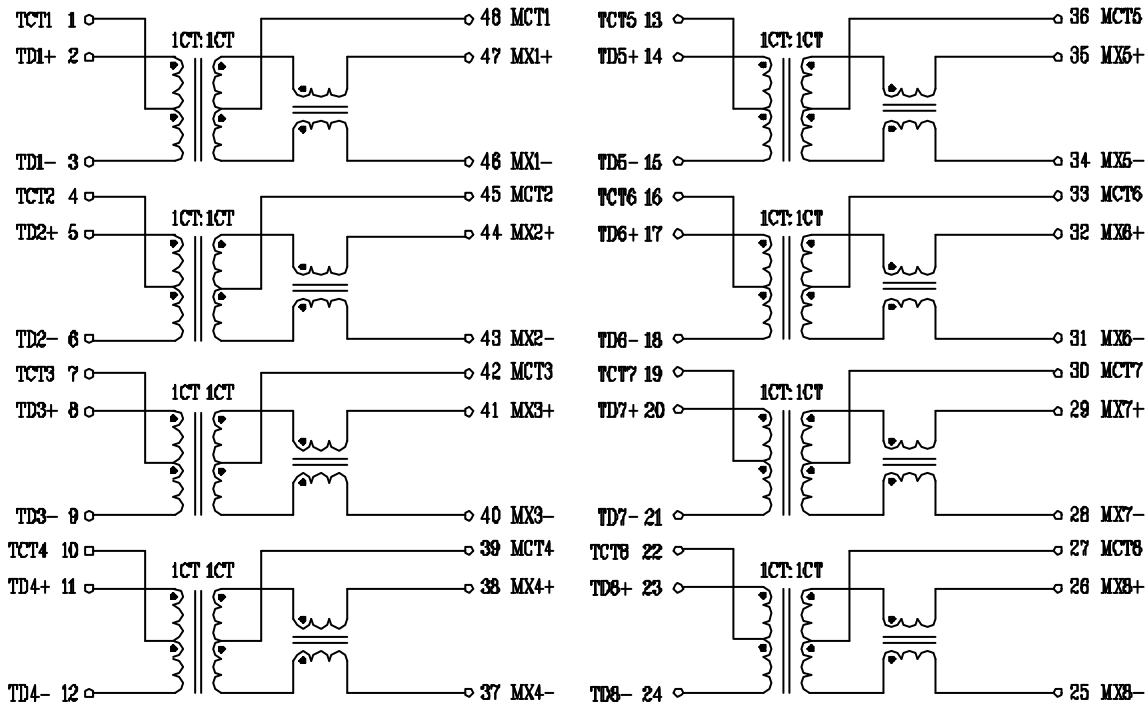



1000 BASE -T DUAL PORT MAGNETICS MODULES

P/N: GS5014-1 LF DATA SHEET

Mechanical

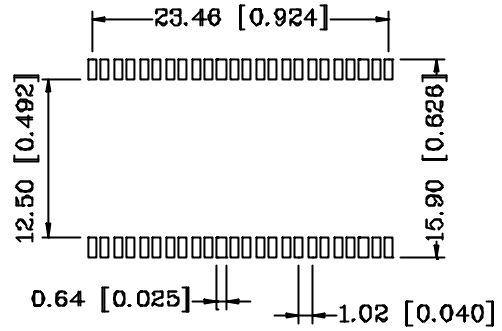
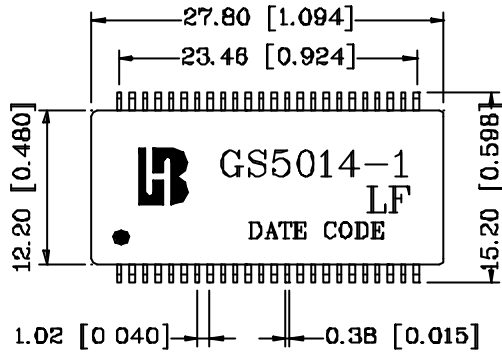

SUGGESTED PAD LAYOUT

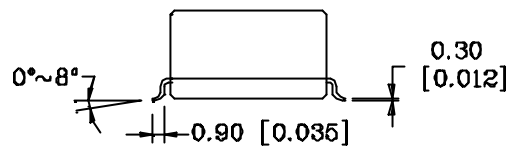
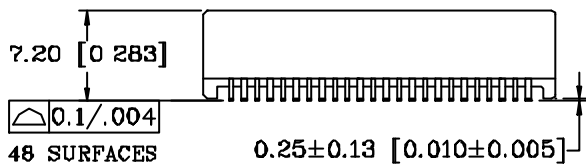

Units: mm [Inches] Tolerance: xx.x0±0.25 [0.010]  
 0.xx±0.05 [0.002]