

FEATURES

- adjustable gain to 48 dB
- capable of driving low impedance receiver
- low component count, 3 small capacitors and 1 resistor
- gain trim can be used as vol. control for reduced noise
- minimal start-up transient
- no gain expansion

STANDARD PACKAGING

- 10 pin MICROpac
- 10 pin PLID®
- 10 pin SLT

CIRCUIT DESCRIPTION

The GS551 is a 10 pin, low voltage, class B amplifier which operates over a battery range of 1.1 VDC to 3 VDC.

The GS551 consists of three gain blocks. The first block is an inverting amplifier with the gain set by two external resistors. The gain trim feature can be used as a volume control in hearing aid applications. The second block is an inverting unity gain amplifier which serves as a phase splitter. The outputs from the first and second blocks drive the differential input of the third block. The third block has a fixed AC gain of 28 dB when driving a receiver.

The amplifier has internal compensation eliminating the need for a capacitor across the receiver. Two ground pins are available for "Star" grounding to reduce any second order harmonic distortion introduced by ground line resistance.

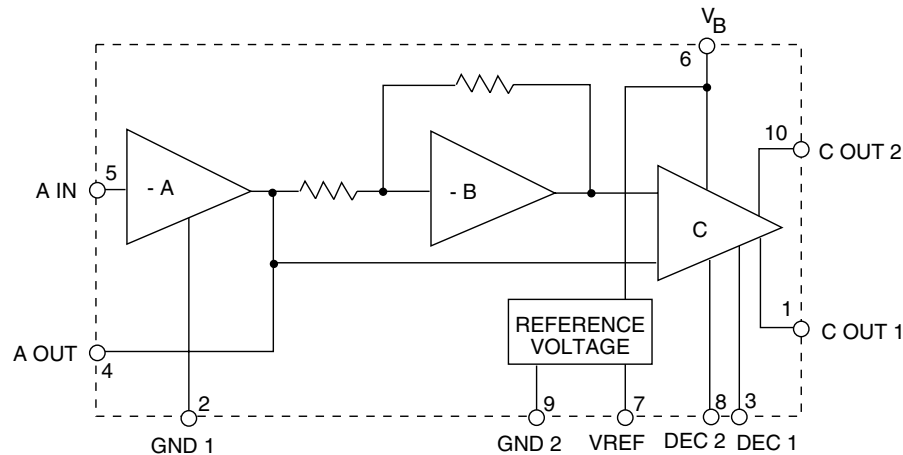

U.S. Patent No. 4,719,430
Other Patents Pending

BLOCK DIAGRAM

ABSOLUTE MAXIMUM RATINGS

PARAMETER	VALUE/UNITS
Supply Voltage	5 VDC
Operating Temperature	-10 to +40 °C
Storage Temperature	-20 to +70 °C

CAUTION
CLASS 1 ESD SENSITIVITY

PIN CONNECTION

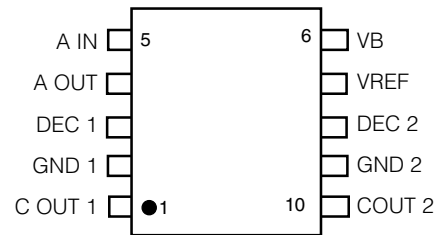

ELECTRICAL CHARACTERISTICS

Conditions: Frequency = 1 kHz, Temperature = 25°C, Supply Voltage $V_B = 1.3$ VDC

PARAMETER	SYMBOL	CONDITIONS	MIN	TYP	MAX	UNITS
Gain	A_V	$V_O = 0.707$ VRMS	46	48	50	dB
Amplifier Current	I_{AMP}		120	220	335	μ A
Transducer Current	I_{TRANS}		120	250	390	μ A
Input Referred Noise	IRN	NFB 0.2 to 10 kHz at 12 dB/Oct	-	1.3	2.5	μ V
Total Harmonic Distortion	THD	$V_O = 0.707$ VRMS	-	0.25	1.3	%
		$V_O = 1.3$ VRMS	-	0.3	1.5	%
Stable with R_B to	R_{STAB}	$R_B = 22\Omega$	-	-	22	Ω
Maximum Output Current	I_{OUT}	$V_{P8} = 0$	-	>35	-	mA

All parameters remain as shown in Test Circuit unless otherwise stated in "Conditions" column

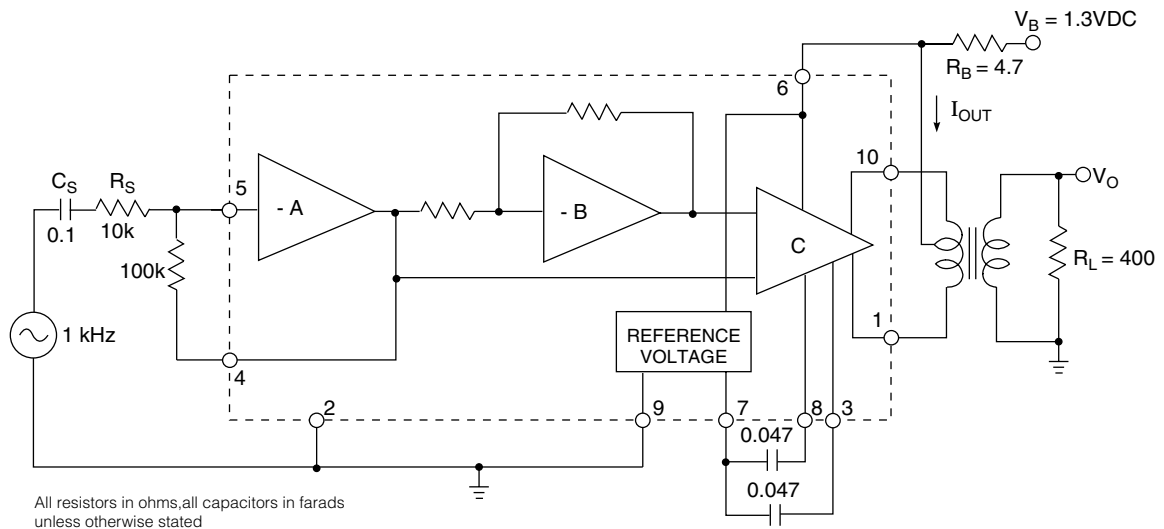

Fig. 1 Test Circuit

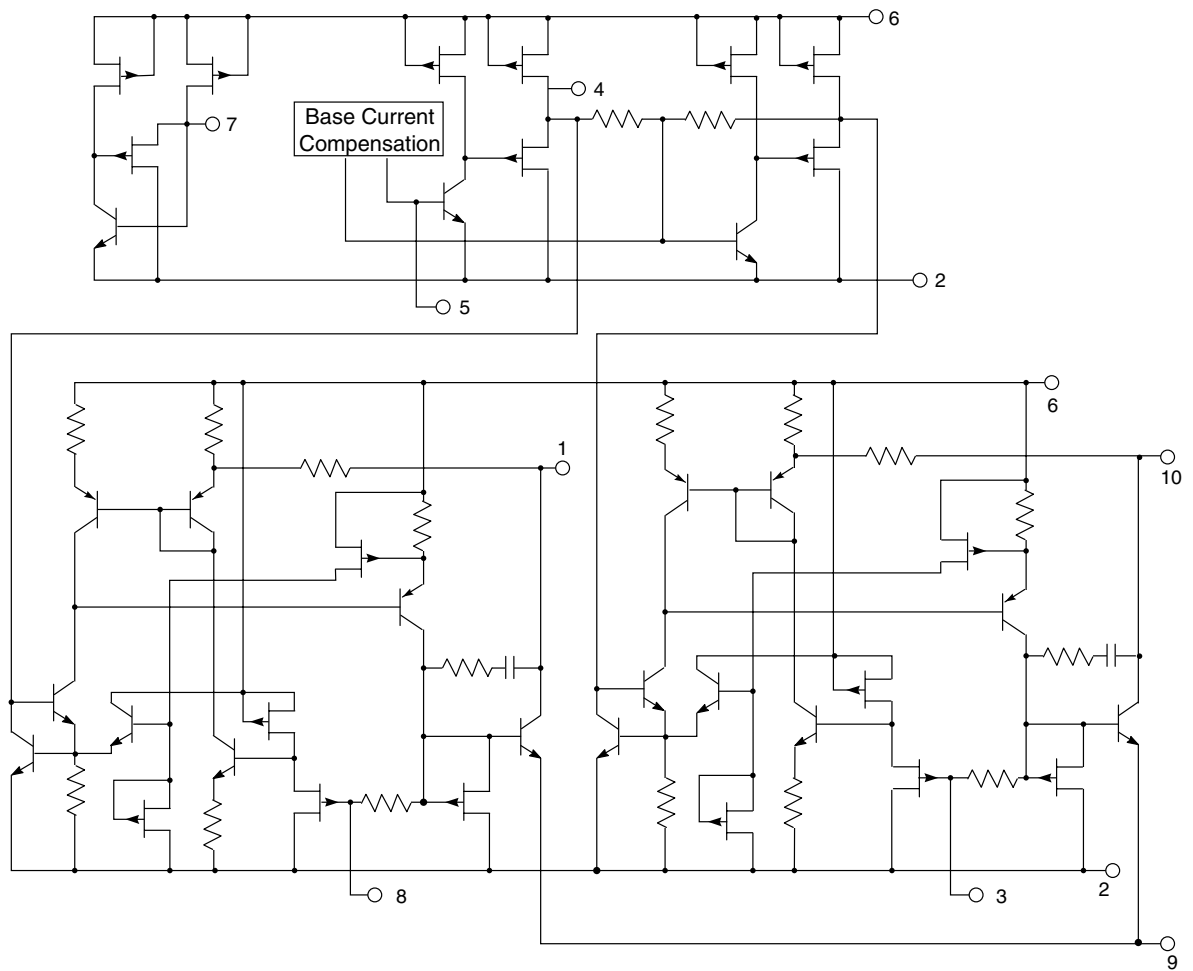

Fig. 2 GS551 Functional Schematic

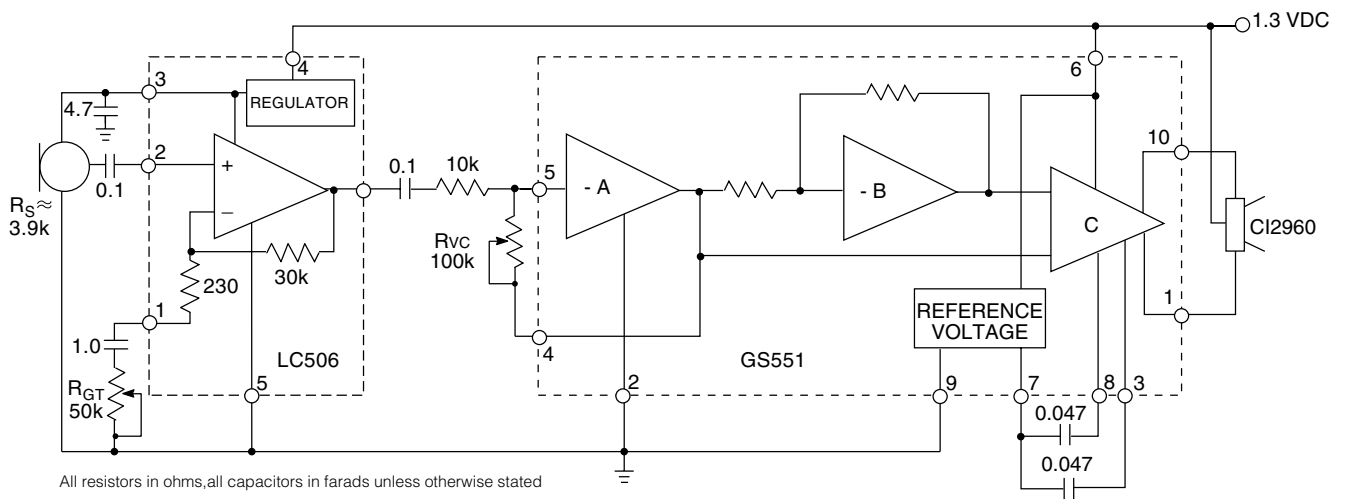

Fig. 3 Application Circuit

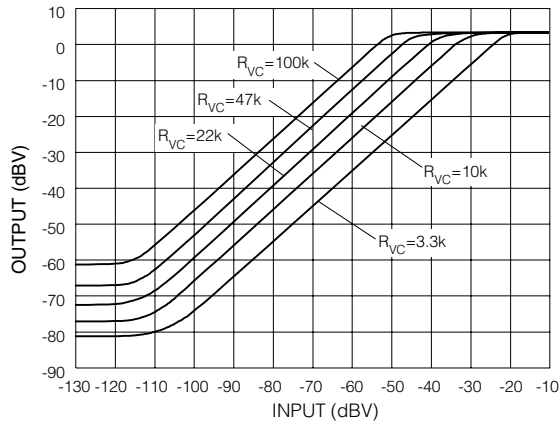

Fig. 4 I/O Characteristics at Various Gain Settings ($R_S=3.92k$)

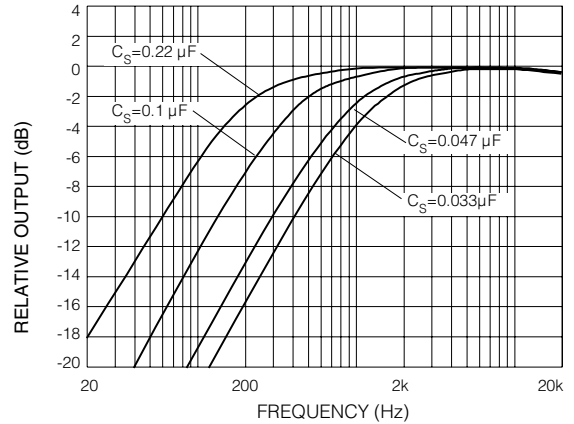

Fig. 5 Closed Loop Frequency Response at Various C_S Values ($R_S=3.92k$)

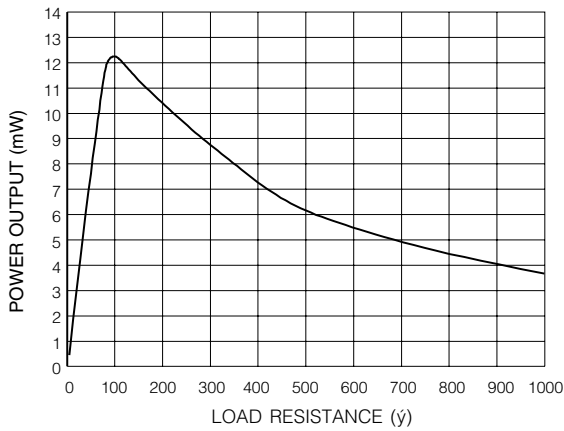

Fig. 6 Power Output vs Load Resistance at 7% Distortion, $R_B=0\Omega$, $V_B=1.35V$

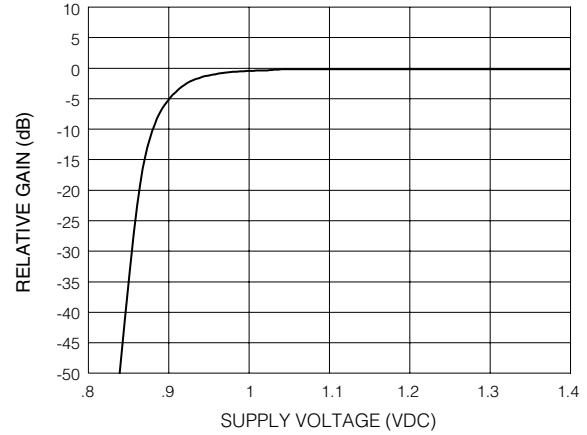

Fig. 7 Gain vs Supply Voltage

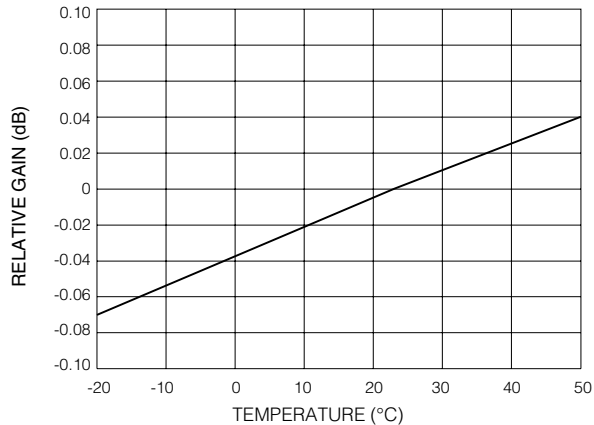

Fig. 8 Gain vs Temperature

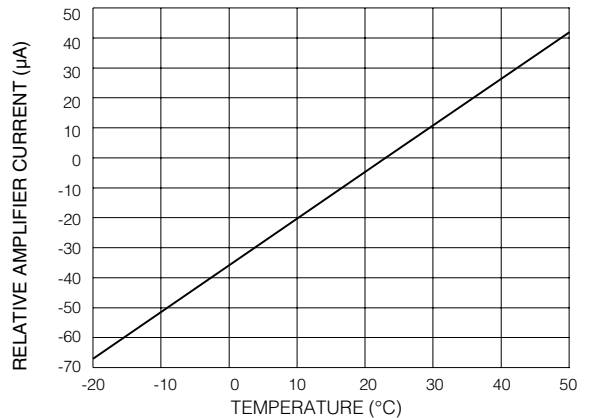

Fig. 9 Amplifier Current vs Temperature

GENNUM CORPORATION
 MAILING ADDRESS:
 P.O. Box 489, Stn. A, Burlington, Ontario, Canada L7R 3Y3
 Tel. +1 (905) 632-2996 Fax +1 (905) 632-2814
 SHIPPING ADDRESS:
 970 Fraser Drive, Burlington, Ontario, Canada L7L 5P5

GENNUM JAPAN CORPORATION
 Shinjuku Green Tower Building 27F 6-14-1, Nishi Shinjuku Shinjuku-ku,
 Tokyo 160-0023 Japan Tel: +81 (03) 3349-5501 Fax: +81 (03) 3349-

DOCUMENT IDENTIFICATION: DATA SHEET
 The product is in production. Gennum reserves the right to make changes at any time to improve reliability, function or design, in order to provide the best product possible.

REVISION NOTES:
 Updated standard packaging information.

Gennum Corporation assumes no responsibility for the use of any circuits described herein and makes no representations that they are free from patent infringement.

© Copyright August 1988 Gennum Corporation. All rights reserved.

Printed in Canada.