



NO LUBRICATION REQUIRED

Description

The body is made from an extruded stove enamelled aluminium section and fitted with hard coated aluminium end plates having right and left hand threads, these should only be removed using the correct size face spanner.

Vibration is produced by the centrifugal force of the positive and negative unbalanced moments in the rotor. The rotor is supported on two heavy duty prelubricated matched sealed bearings. A special high performance grease ensures a long working life.

The inner and outer raceways of the bearings are designed so that the bearings can easily be removed without using special tools.

Maximum temperature 120°C = 250°F

Noise level range 60 to 75 dBA

Application

The GT range of turbine vibrators are particularly suitable for use in the food and pharmaceutical industries where exhaust contaminated with oil is unacceptable. No airline lubrication is required, but clean filtered air is essential.

These vibrators are extremely quiet and produce low noise levels on most applications, thus helping to conform with noise regulations.

PNEUMATIC TURBINE VIBRATORS

Type GT

VIBRATECHNIQUES LTD

2 CHAPEL ROAD

BRIGHTON BN41 1PF

TELEPHONE: 01273 430977

FAX: 01273 430978

VIBTEC

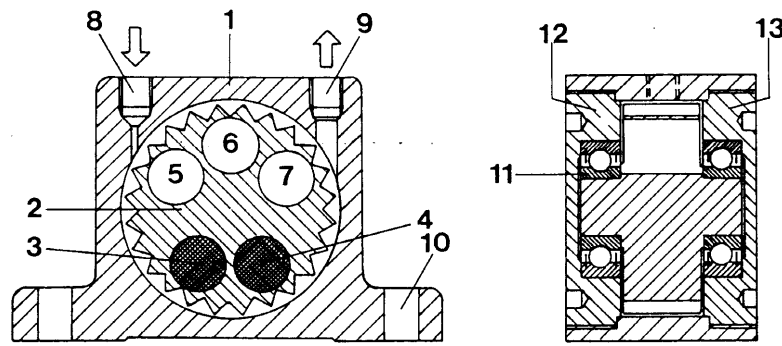

- 1 Extruded aluminium alloy body
- 2 Alu-Turbine wheel, hard coated
- 3/4 High density mass positive moment
- 5/7 Cavities giving negative moment
- 8 Air inlet
- 9 Air exhaust
- 10 Base mounting holes
- 11 Special prelubricated matched sealed bearings
- Alu-Endplates, hard coated
- 12 with left hand thread
- 13 with right hand thread

PERFORMANCE DATA

Type	Frequency V.P.M.			Centrifugal Force						Air Consumption/Minute					
	2 Bar	4 Bar	6 Bar	2 Bar = 29 PSI		4 Bar = 58 PSI		6 Bar = 87 PSI		2 Bar = 29 PSI		4 Bar = 58 PSI		6 Bar = 87 PSI	
	29 PSI	58 PSI	87 PSI	N	LBS	N	LBS	N	LBS	Ltr	CF	Ltr	CF	Ltr	CF
GT4	14,000	15,000	15,000	135	30	180	40	200	44	33	1.1	58	2	83	2.9
GT6	11,500	12,000	12,500	130	29	175	39	210	47	33	1.1	58	2	83	2.9
GT8	36,000	42,000	46,000	563	126	766	172	919	206	46	1.6	80	2.8	112	3.9
GT10	27,500	35,000	37,500	583	131	946	212	1,086	243	46	1.6	80	2.8	112	3.9
GT10S	17,000	23,000	25,000	650	146	1,350	303	2,000	448	46	1.6	80	2.8	112	3.9
GT13	26,000	30,000	33,000	1,451	325	1,932	433	2,338	524	120	4.2	200	7.0	290	10.2
GT16	17,000	21,500	24,000	1,103	247	1,764	396	2,198	493	120	4.2	200	7.0	290	10.2
GT16S	11,500	15,500	17,000	1,100	247	1,900	426	2,700	605	120	4.2	200	7.0	290	10.2
GT20	17,000	20,000	23,000	2,014	452	2,787	625	3,686	826	185	6.6	325	11.4	455	15.9
GT25	12,000	15,500	17,000	1,784	400	2,977	667	3,581	803	185	6.6	325	11.4	455	15.9
GT25S	8,500	11,000	13,000	2,250	504	3,600	807	4,900	1,098	185	6.6	325	11.4	455	15.9
GT30	13,000	14,000	16,000	4,603	1,032	5,339	1,197	6,973	1,563	330	11.5	530	18.5	745	26.0
GT36	8,000	10,000	13,000	3,060	686	4,781	1,072	8,080	1,812	330	11.5	530	18.5	745	26.0
GT36S	6,100	7,200	8,300	4,100	919	6,200	1,390	7,500	1,681	330	11.5	530	18.5	745	26.0
GT40	7,700	8,800	9,500	4,300	964	7,300	1,636	9,800	2,197	425	15	700	24.7	970	34.2
GT48	6,000	7,500	9,700	4,900	1,098	7,700	1,726	10,500	2,354	425	15	700	24.7	970	34.2
GT48S	-	5,600	6,300	-	-	7,500	1,681	12,000	2,690	425	15	700	24.7	970	34.2

DIMENSIONS

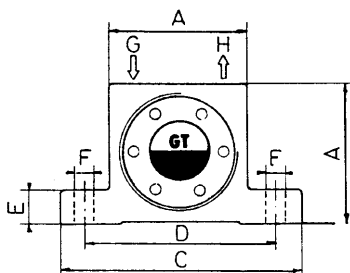

Type	A		Width		C		D		E		F		G/H Thread BSP	Weight	
	mm	inch	mm	inch	mm	inch	mm	inch	mm	inch	mm	inch		Kg	Lbs
GT4	40	1.57	28	1.10	70	2.75	56	2.20	10	0.39	6	0.23	1/8"	.165	.55
GT6														.250	.37
GT8														.165	.55
GT10	50	1.97	33	1.30	86	3.38	68	2.68	12	0.47	7	0.27	1/8"	.255	.56
GT10S														.263	.58
GT13														.565	1.24
GT16	65	2.56	42	1.65	113	4.45	90	3.54	16	0.63	9	0.35	1/4"	.580	1.28
GT16S														.614	1.35
GT20														1.090	2.40
GT25	80	3.15	56	2.20	128	5.04	104	4.09	16	0.63	9	0.35	1/4"	1.120	2.46
GT25S														1.200	2.64
GT30														2.200	4.85
GT36	100	3.94	73	2.87	160	6.30	130	5.12	20	0.79	11	0.43	3/8"	2.300	5.10
GT36S														2.530	5.57
GT40														3.690	8.13
GT48	120	4.72	83	3.26	194	7.63	152	5.98	24	0.94	17	0.66	3/8"	3.890	8.57
GT48S														4.290	9.45

Data obtained with a Kistler Dynamometer.

These frequencies and forces will not be obtained on less rigid mountings and should only be used as a guide.

We reserve the right to improve, modify or withdraw specifications without notice or obligation.