



H12N65 Series

N-Channel Power MOSFET (650V,12A)

Applications

- Switch Mode Power Supply
- Uninterruptable Power Supply
- High Speed Power Switching

Features

- H12N65 Series is a High voltage NChannel enhancement mode power MOSFET chip fabricated in advanced silicon epitaxial planar technology
- Advanced termination scheme to provide enhanced voltageblocking capability
- Avalanche Energy Specified
- Source to Drain Diode Recovery Time Comparable to a Discrete Fast Recovery Diode;
- The packaged product is widely used in AC-DC power suppliers, DCDC converters and Hbridge PWM motor drivers

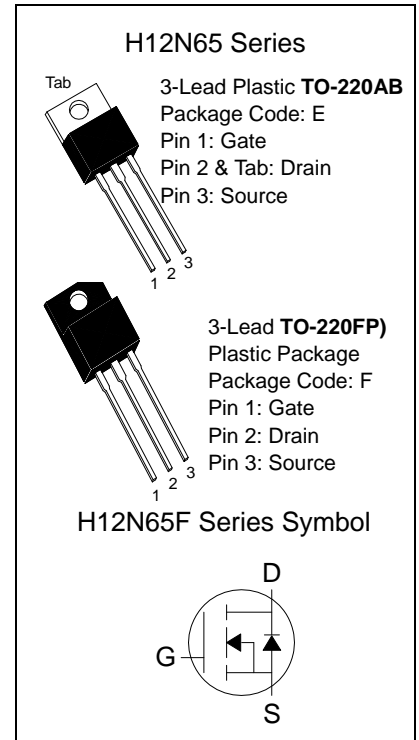

Absolute Maximum Ratings

Symbol	Parameter	Value		Units
V_{DSS}	Drain-Source Voltage	650		V
I_D	Drain Current ($V_{GS}@10V, T_C=25^\circ C$)	12		A
V_{GS}	Gate-to-Source Voltage	± 30		V
P_D	Total Power Dissipation ($T_C=25^\circ C$)	TO-220AB	175	W
		TO-220FP	50	
	Linear Derating Factor	TO-220AB	1.43	W/ $^\circ C$
		TO-220FP	0.41	
E_{AS}	Single Pulse Avalanche Energy ^{*2}	990		mJ
I_{AR}	Avalanche Current ^{*1}	12		A
E_{AR}	Repetitive Avalanche Energy ^{*1}	22		mJ
T_J	Operating Junction Temperature Range	-55 to 150		$^\circ C$
T_{stg}	Storage Temperature Range	-55 to 150		$^\circ C$

*1: Repetitive rating; pulse width limited by max. junction temperature

*2: Starting $T_J=25^\circ C, L=1.2mH, R_G=25\Omega, I_{AS}=10A$

*3: $I_{SD}\leq 14A, di/dt\leq 130A/us, V_{DD}\leq V_{(BR)DSS}, T_J\leq 150^\circ C$

Thermal Characteristics

Symbol	Parameter	Value		Units
$R_{\theta JC}$	Thermal Resistance Junction to Case (Max.)	TO-220AB	1.3	$^\circ C/W$
		TO-220FP	5	
$R_{\theta JA}$	Thermal Resistance Junction to Ambient (Max.)	62		$^\circ C/W$



Electrical Characteristics (T_j=25°C, unless otherwise specified)

Symbol	Characteristic	Test Conditions	Min.	Typ.	Max.	Unit
V _{(BR)DSS}	Drain-Source Breakdown Voltage	V _{GS} =0V, I _D =250uA	650	-	-	V
ΔV _{(BR)DSS} /ΔT _J	Breakdown Voltage Temp. Coefficient	Reference to 25°C, I _D =1mA	-	0.58	-	V/°C
I _{DSS}	Drain-Source Leakage Current	V _{DS} =600V, V _{GS} =0V	-	-	10	uA
	Drain-Source Leakage Current	V _{DS} =400V, V _{GS} =0V, T _j =125°C	-	-	60	uA
I _{GSSF}	Gate-Source Forward Leakage	V _{gsf} =30V, V _{DS} =0V	-	-	100	nA
I _{GSSR}	Gate-Source Reverse Leakage	V _{gsr} =-30V, V _{DS} =0V	-	-	-100	nA
V _{GS(th)}	Gate Threshold Voltage	V _{DS} =V _{GS} , I _D =250uA	2	-	4	V
R _{DS(on)}	Static Drain-Source On-Resistance	V _{GS} =10V, I _D =6.0A ^{*4}	-	-	0.8	Ω
g _{FS}	Forward Transconductance	V _{DS} =20V, I _D =6.0A	-	5	-	S
C _{iss}	Input Capacitance	V _{DS} =25V, V _{GS} =0V, f=1MHz	-	1830	-	pF
C _{oss}	Output Capacitance		-	157	-	
C _{riss}	Reverse Transfer Capacitance		-	2.2	-	
t _{d(on)}	Turn-on Delay Time	(V _{DD} =325V, I _D =12A, R _G =4.7Ω, R _D =32Ω) ^{*4}	-	50	-	ns
t _r	Rise Time		-	50	-	
t _{d(off)}	Turn-off Delay Time		-	311	-	
t _f	Fall Time		-	55	-	
Q _g	Total Gate Charge	(V _{DS} =520V, I _D =12A, V _{GS} =10V) ^{*4}	-	52	-	nC
Q _{gs}	Gate-Source Charge		-	10	-	
Q _{gd}	Gate-Drain Charge		-	19	-	

Source-Drain Diode

Symbol	Characteristic		Min.	Typ.	Max.	Units
I _S	Continuous Source Current (Body Diode)	Page1 MOSFET symbol showing the integral reverse P-N junction diode.	-	-	12	A
V _{SD}	Diode Forward Voltage	I _S =12A, V _{GS} =0V, T _J =25°C ^{*4}	-	-	1.4	V

*4: Pulse Test: Pulse Width≤300us, Duty Cycle≤2%

*5: C_{oss} eff. Is a fixed capacitance that gives the same charging time as C_{oss} while V_{DS} is rising from 0 to 80% V_{DSS}



Characteristics Curve

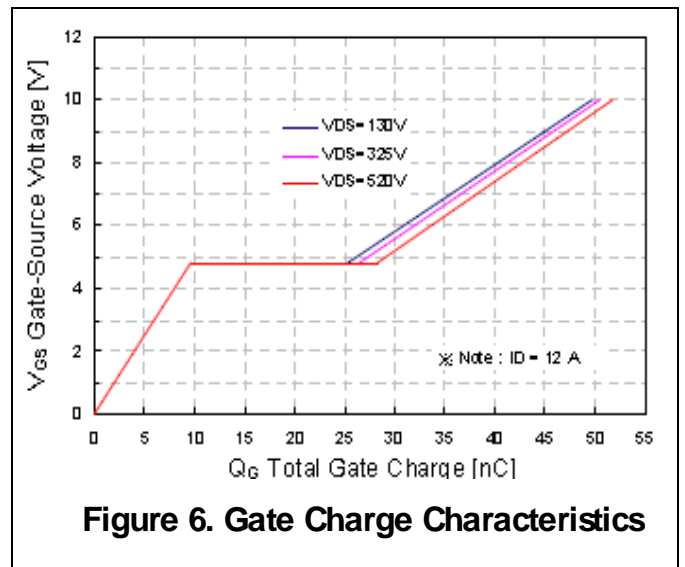
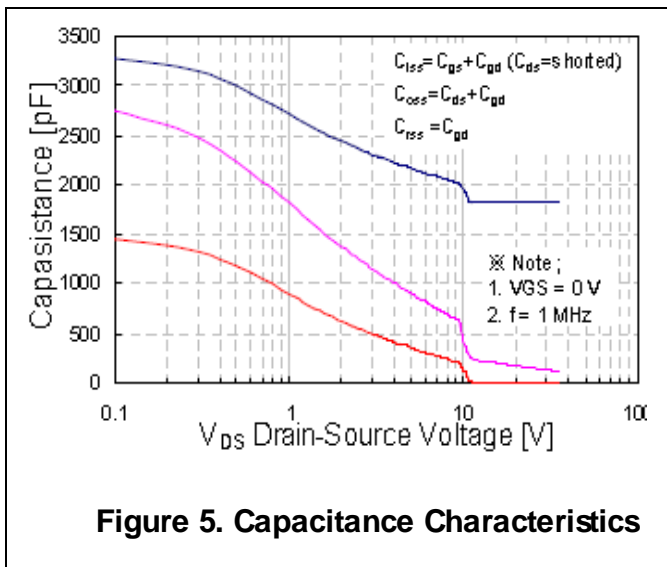
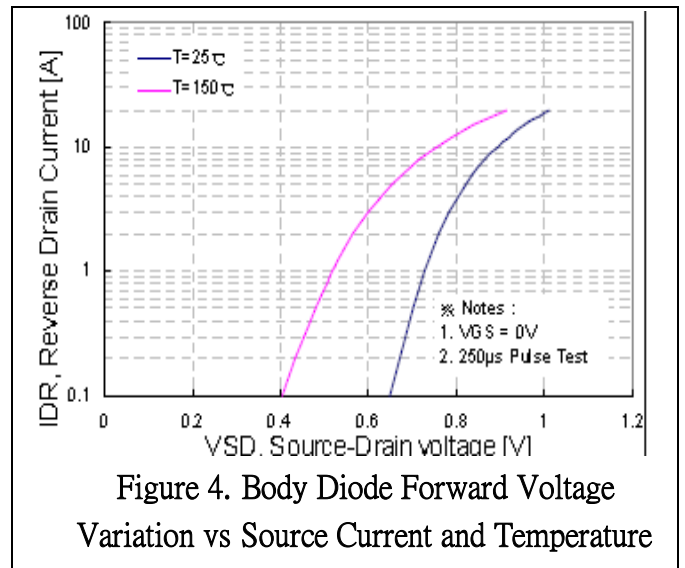
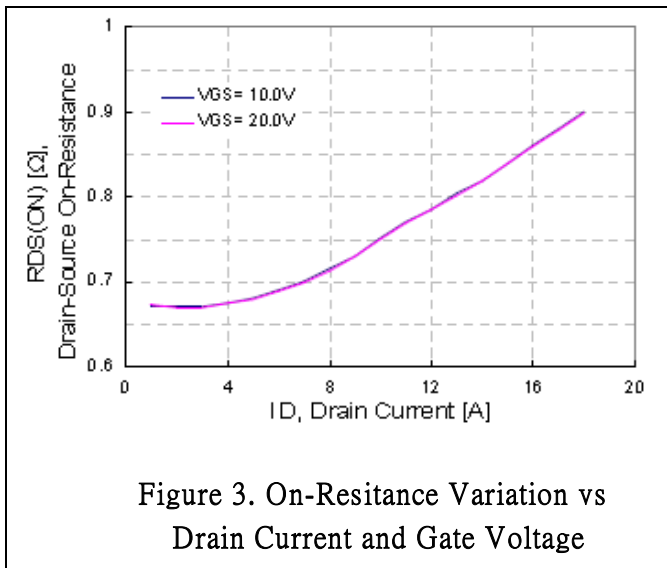
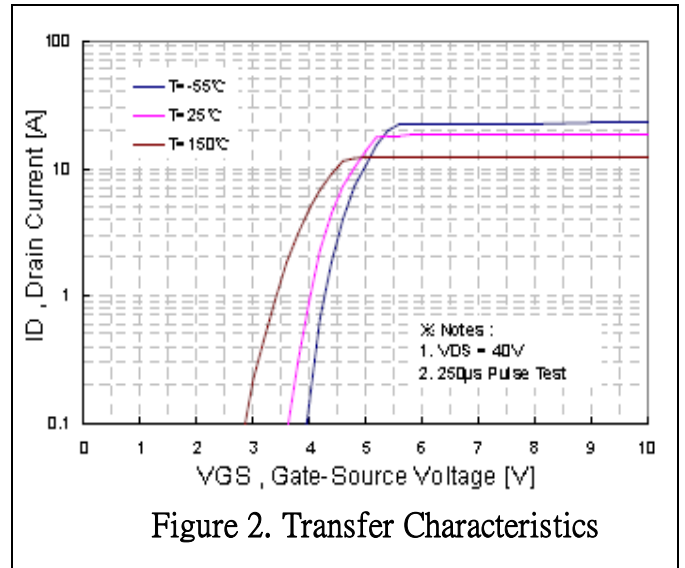
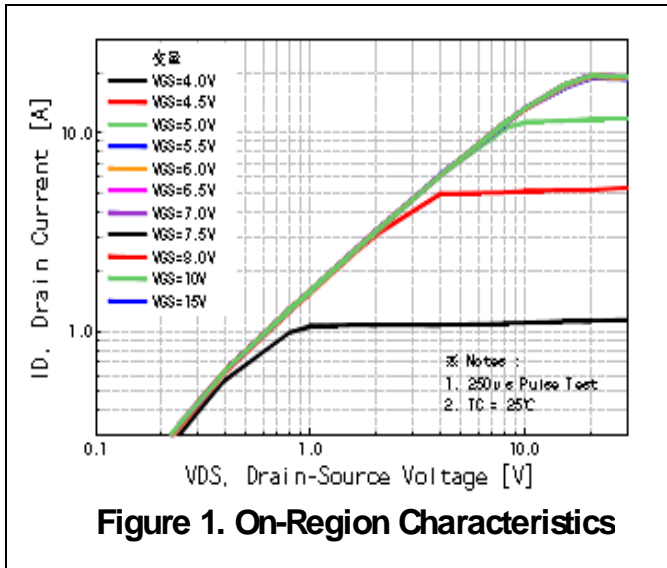



Characteristics Curve

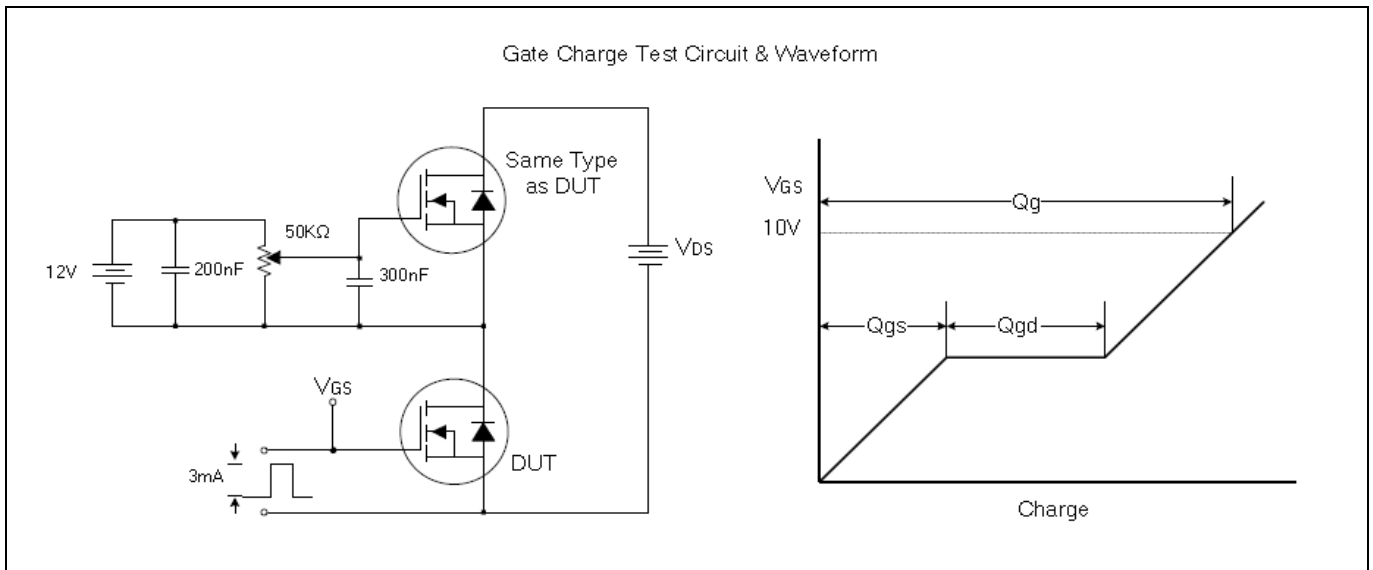
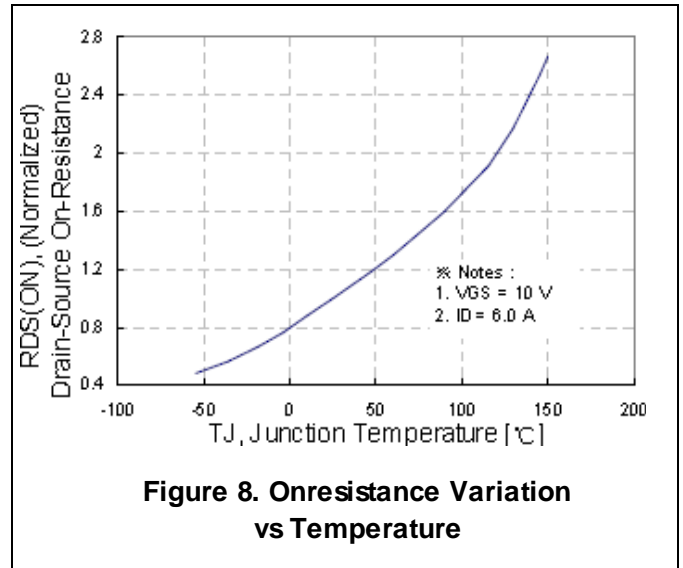
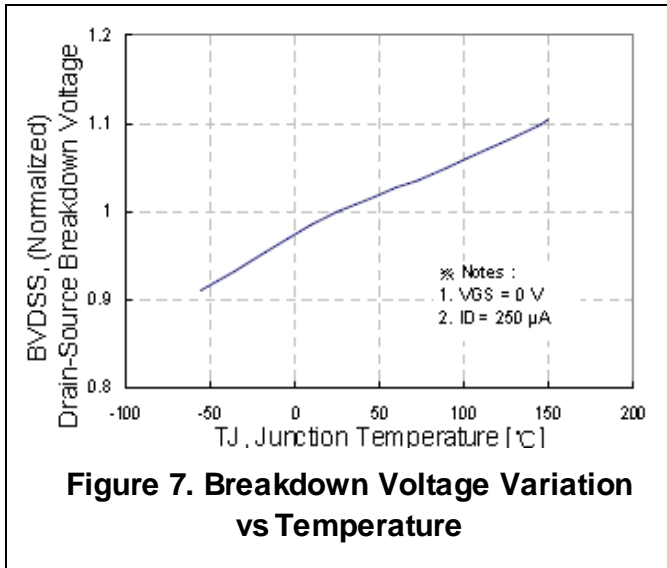

Resistive Switching Test Circuit & Waveform

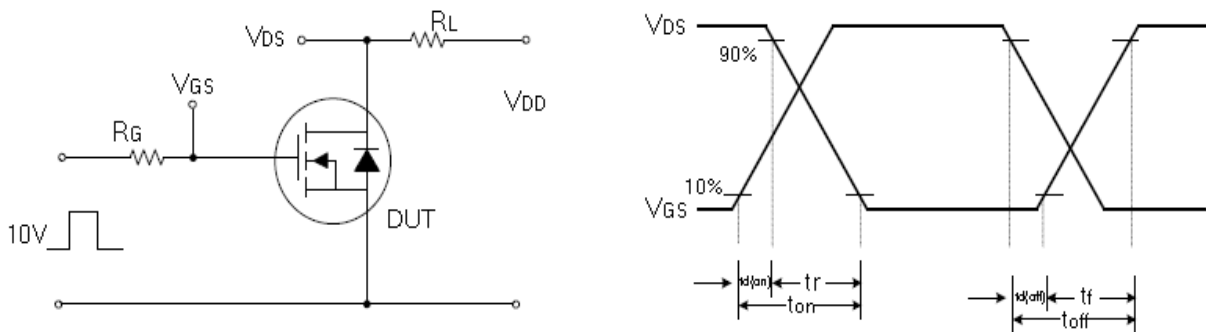



TO-220AB Dimension

3-Lead TO-220AB
Plastic Package
HSMC Package Code: E

Marking:

Pb Free Mark
Pb-Free: "●" (Note)
Normal: None

Date Code Control Code

Note: Green label is used for pb-free packing

Pin Style: 1.Gate 2 & Tab.Drain 3.Source

Material:

- Lead solder plating: Sn60/Pb40 (Normal), Sn/3.0Ag/0.5Cu or Pure-Tin (Pb-free)
- Mold Compound: Epoxy resin family, flammability solid burning class: UL94V-0

DIM	Min.	Max.
A	5.58	7.49
B	8.38	8.90
C	4.40	4.70
D	1.15	1.39
E	0.35	0.60
F	2.03	2.92
G	9.66	10.28
H	-	*16.25
I	-	*3.83
J	3.00	4.00
K	0.75	0.95
L	2.54	3.42
M	1.14	1.40
N	-	*2.54
O	12.70	14.27
P	14.48	15.87

*: Typical, Unit: mm

TO-220FP Dimension

3-Lead TO-220FP
Plastic Package
HSMC Package Code: F

Marking:

Pb Free Mark
Pb-Free: "●" (Note)
Normal: None

Date Code Control Code

Note: Green label is used for pb-free packing

Pin Style: 1.Gate 2.Drain 3.Source

Material:

- Lead solder plating: Sn60/Pb40 (Normal), Sn/3.0Ag/0.5Cu or Pure-Tin (Pb-free)
- Mold Compound: Epoxy resin family, flammability solid burning class: UL94V-0

DIM	Min.	Max.
A	6.48	7.40
C	4.40	4.90
D	2.34	3.00
E	0.45	0.80
F	9.80	10.36
G	3.10	3.60
I	2.70	3.43
J	0.60	1.00
K	2.34	2.74
L	12.48	13.60
M	15.67	16.20
N	0.90	1.47
O	2.00	2.96
$\alpha 1/2/4/5$	-	*5°

Unit: mm

Important Notice:

- All rights are reserved. Reproduction in whole or in part is prohibited without the prior written approval of HSMC.
- HSMC reserves the right to make changes to its products without notice.
- **HSMC semiconductor products are not warranted to be suitable for use in Life-Support Applications, or systems.**
- HSMC assumes no liability for any consequence of customer product design, infringement of patents, or application assistance.

Head Office And Factory:

• **Head Office** (Hi-Sincerity Microelectronics Corp.): 10F.,No. 61, Sec. 2, Chung-Shan N. Rd. Taipei Taiwan R.O.C.
 Tel: 886-2-25212056 Fax: 886-2-25632712, 25368454



Soldering Methods for HSMC's Products

1. Storage environment: Temperature=10°C~35°C Humidity=65%±15%
2. Reflow soldering of surface-mount devices

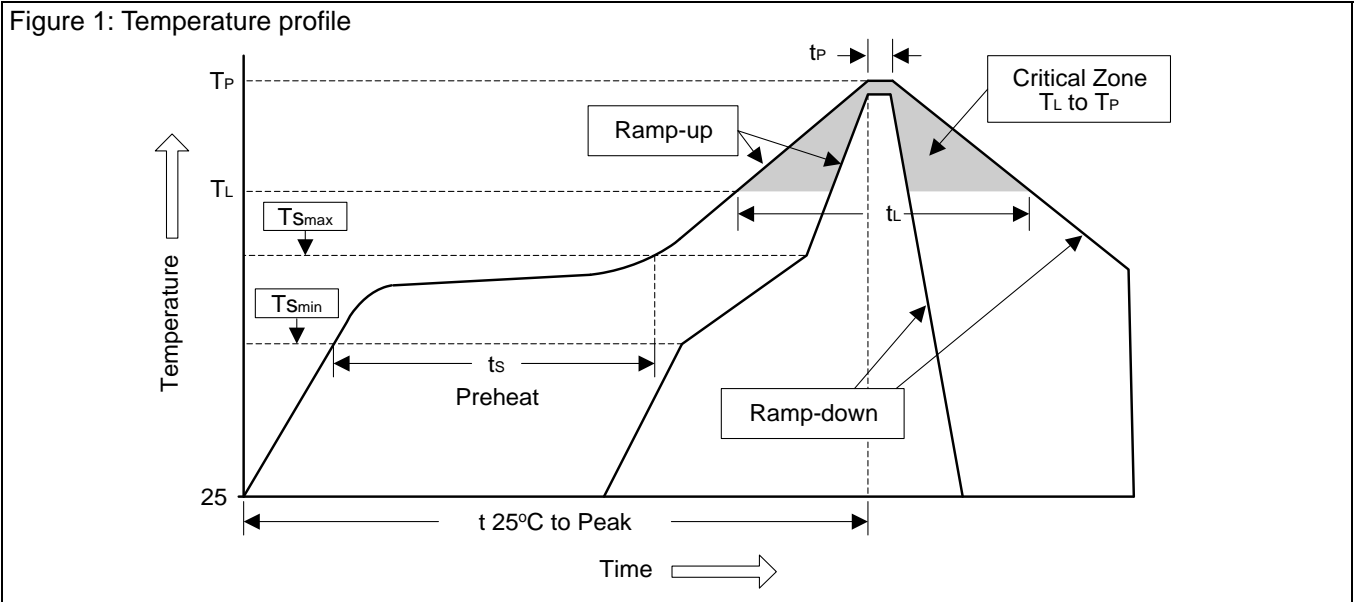

Profile Feature	Sn-Pb Eutectic Assembly	Pb-Free Assembly
Average ramp-up rate (T_L to T_P)	<3°C/sec	<3°C/sec
Preheat		
- Temperature Min (T_{Smin})	100°C	150°C
- Temperature Max (T_{Smax})	150°C	200°C
- Time (min to max) (t_s)	60~120 sec	60~180 sec
T_{Smax} to T_L		
- Ramp-up Rate	<3°C/sec	<3°C/sec
Time maintained above:		
- Temperature (T_L)	183°C	217°C
- Time (t_L)	60~150 sec	60~150 sec
Peak Temperature (T_P)	240°C +0/-5°C	260°C +0/-5°C
Time within 5°C of actual Peak Temperature (t_P)	10~30 sec	20~40 sec
Ramp-down Rate	<6°C/sec	<6°C/sec
Time 25°C to Peak Temperature	<6 minutes	<8 minutes

3. Flow (wave) soldering (solder dipping)

Products	Peak temperature	Dipping time
Pb devices.	245°C ±5°C	5sec ±1sec
Pb-Free devices.	260°C +0/-5°C	5sec ±1sec