

HA11223

PLL FM Stereo Demodulator with Pilot Cancel

■ FEATURES

- External parts are small. Coil is not used.
- Pilot cancel function built-in.
- Other functions: stereo demodulation, stereo/Monaural automatic changeover and stereo indicator lamp driving circuit.
- Stereo indicator lamp lighting and stereo/Monaural change-over operations are synchronous.
- Low distortion by the adoption of 100% local feedback circuit. (0.01% typ, 300 mV Monaural input.)
- High input impedance (75 k Ω typ.)
- High S/N. (86dB typ. 300 mV input.)
- Distortion factor improved by PLL circuit (0.06% typ. 10 kHz, Main-ch input).

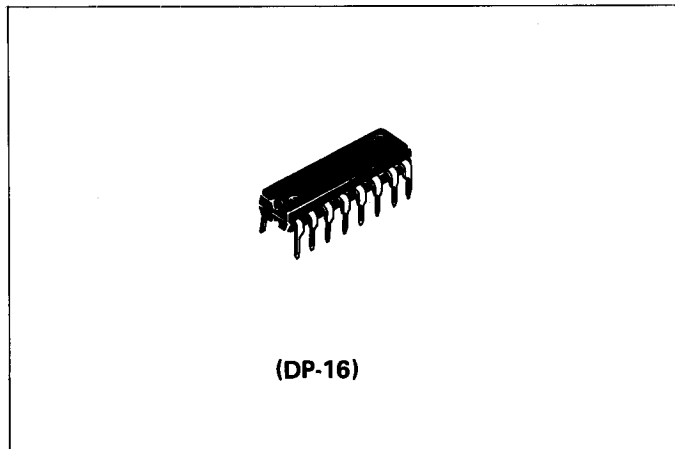

■ BLOCK DIAGRAM AND TYPICAL APPLICATION CIRCUIT

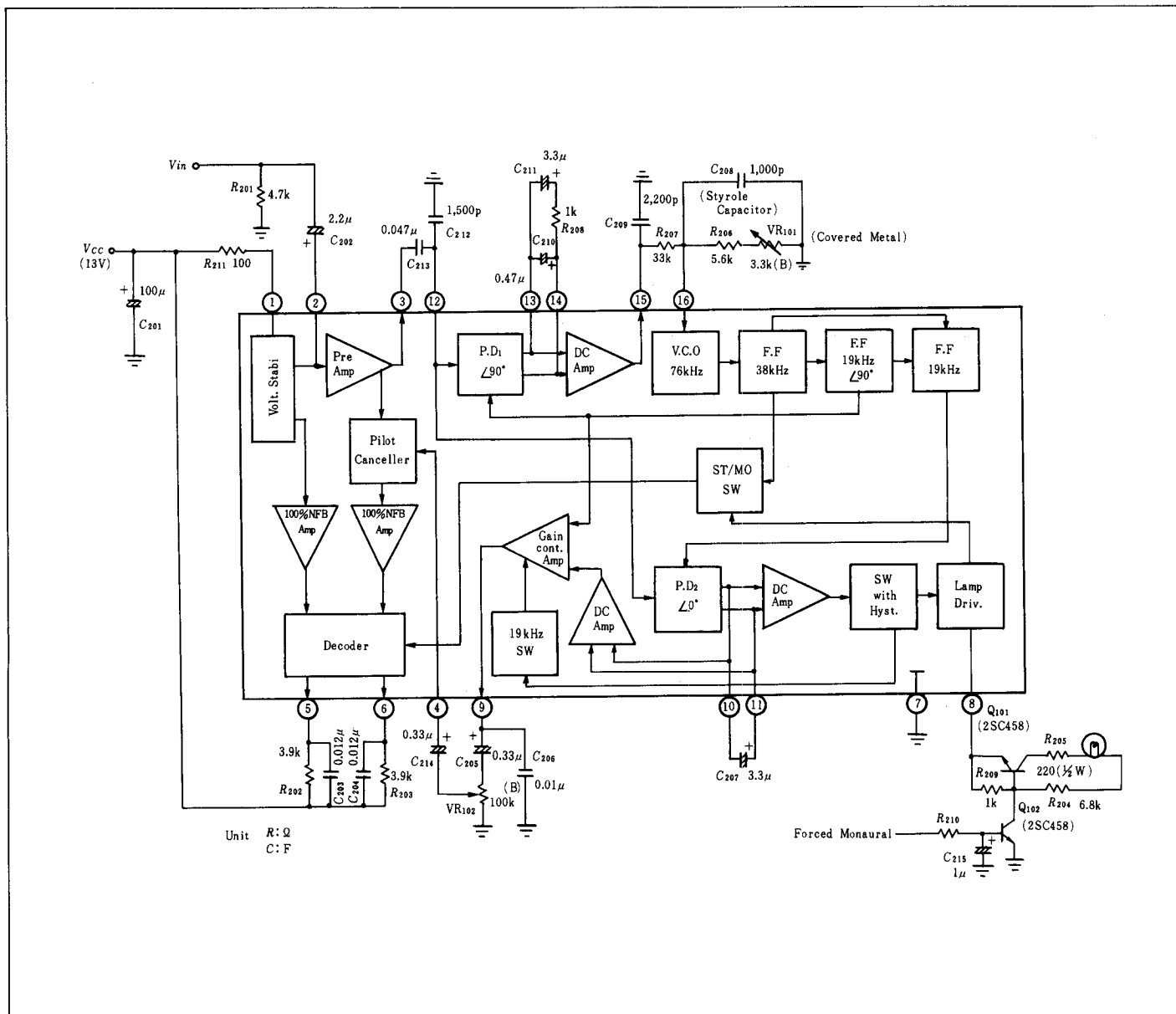

■ CIRCUIT SCHEMATIC AND TYPICAL APPLICATION CIRCUIT

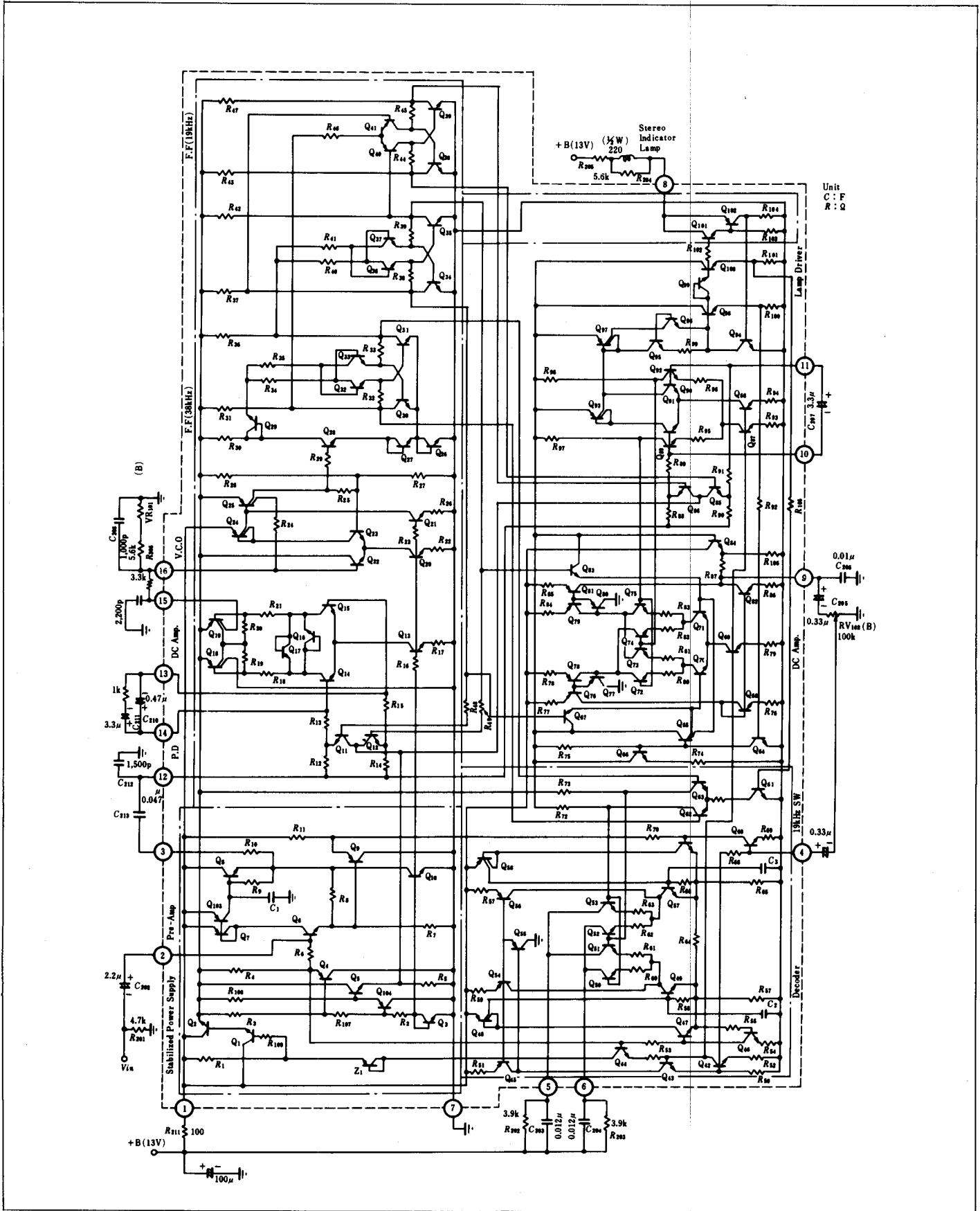

■ ABSOLUTE MAXIMUM RATINGS (Ta=25°C)

Item	Symbol	Rating	Unit
Supply Voltage	V _{CC}	16	V
Power Dissipation*	P _T	500	mW
Operating Temperature	T _{opr}	-20 to +75	°C
Storage Temperature	T _{stg}	-55 to +125	°C
Lamp Drive Current	Continous	75	mA
	Peak	100	

* Value at Ta=75°C

■ ELECTRICAL CHARACTERISTICS (V_{CC}=13V, f=1kHz, Ta=25°C unless otherwise noted)

Item	Symbol	Test Condition	min	typ	max	Unit	
Input Impedance	Z _{in}		30	75	—	kΩ	
Channel Separation	Sep	P=30mV, L+R=270mV	100Hz	—	40	—	dB
			1kHz	35	45	—	
			10kHz	—	40	—	
Stereo Total Harmonic Distortion	ST, T.H.D	P=30mV, L+R=270mV	100Hz	—	0.04	—	%
			1kHz	—	0.02	0.08	
			10kHz	—	0.05	—	
Output Voltage	V _{out}	V _{in} =300mV	185	240	310	mV	
Channel Balance	C.B	V _{in} =300mV	—	0	—	dB	
Monaural Total Harmonic Distortion	M _{ono} , T.H.D	V _{in} =300mV	—	0.01	0.08	%	
Pilot Level for Lamp ON	L(ON)		8	11.5	15	mV	
Stereo Lamp Hysteresis			—	4	—	dB	
Carrier Leak	C.L	P=30mV, L+R=270mV	19kHz	55	60	—	dB
			38kHz	—	35	—	
SCA Rejection Ratio	SCA R _{ej}	P=30mV, L+R=270mV, SCA=30mV, f _{SCA} =67kHz	—	80	—	dB	
Signal-to-noise Ratio	S/N	V _{in} =300mV, R _g =4.7kΩ	80	86	—	dB	
Capture Range	C.R	P=30mV	—	±3.5	—	%	
Max Input Signal	V _{in}	P=10%, L+R=90%, T.H.D≤0.5%	—	1.2	—	V	
Total Current Drain	I _T		—	17	—	mA	

■ TEST CIRCUIT

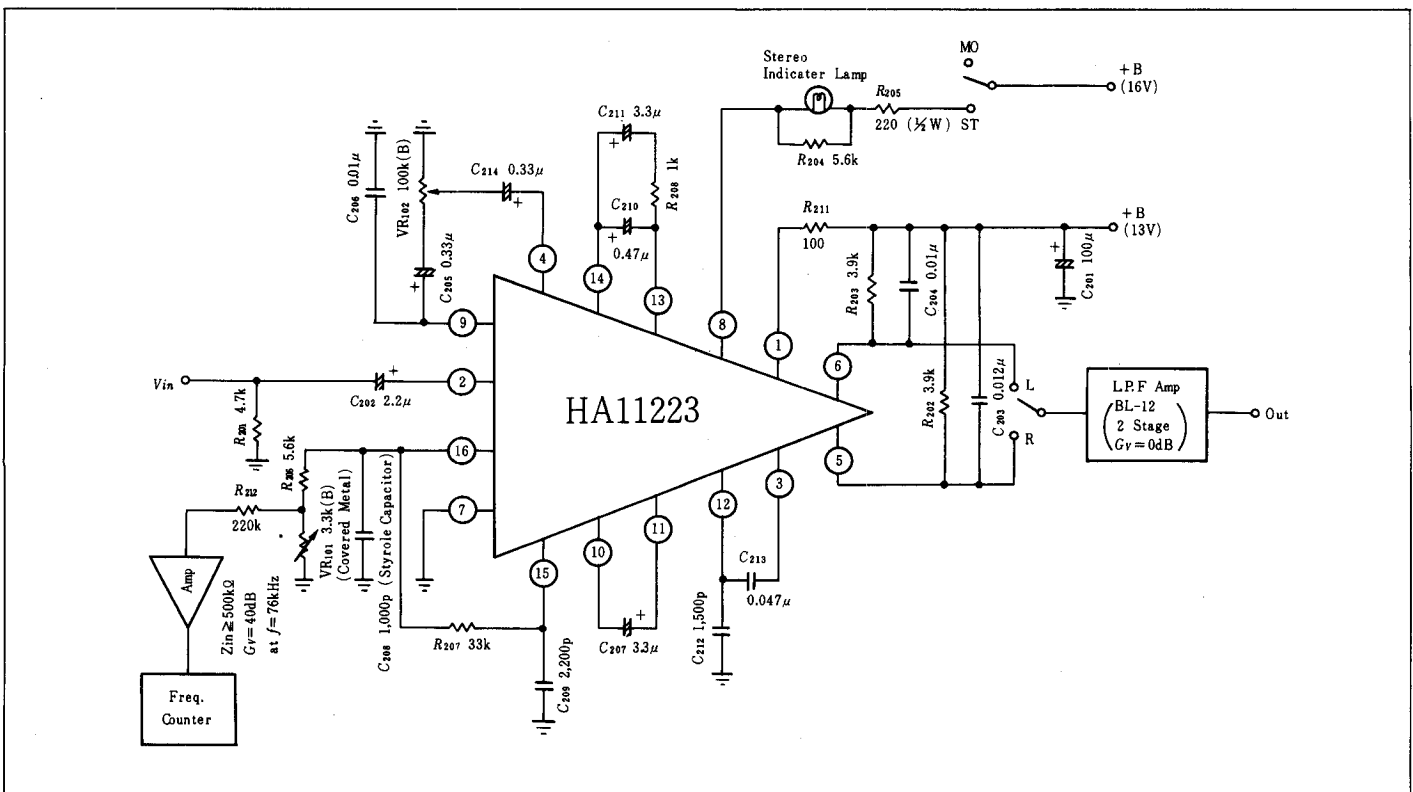

■ EXTERNAL PARTS

Parts No.	Recommended Value	Purpose	Influence		Remarks
			Smaller than Recommended Value	Larger than Recommended Value	
R ₂₀₁	4.7kΩ	Input equivalent resistance	—	—	—
C ₂₀₁	100μF	Power source decoupling	—	—	—
C ₂₀₂	2.2μF	Input DC cut-off	Deterioration of f-characteristics	Larger pop noise	—
R ₂₀₂	3.9kΩ	Load resistance	Smaller output voltage	Deterioration of decrease voltage characteristics	—
R ₂₀₃	3.9kΩ				
C ₂₀₃	0.012μF	Deemphasis characteristics	—	—	—
C ₂₀₄	0.012μF				
R ₂₀₄	5.6kΩ	Countermeasure for damage of stereo indicator lamp	Insufficient lamp illumination	At time of damage to lamp, the stereo will not operate	—
R ₂₀₅	220Ω	Rush current of lamp is limited	IC is damaged by rush current	Insufficient lamp illumination	—
C ₂₀₅	0.33μF	Pilot cancel circuit, DC cut-off	Insufficient amount of pilot cancel	Deterioration of S/N	—
C ₂₁₄	0.33μF				
C ₂₀₆	0.01μF	Wave form for Pilot cancel	Insufficient amount of pilot cancel	Pilot cancel adjustment is not possible	—
VR ₁₀₂	100kΩ (B)	Adjustment of Pilot cancel	Pilot cancel adjustment is not possible	Deterioration of S/N	—
R ₂₀₆	5.6kΩ	Adjustment of V.C.O. free running freq.	Adjustment of V.C.O. self-propelled freq. is impossible in relation to C ₂₀₆ .		Metal film
VR ₁₀₁	3.3kΩ (B)				
C ₂₀₈	1000pF		High jitter of V.C.O.	Narrower capture range	Styrol condenser
R ₂₀₇	33kΩ	L.P.F. of PLL Loop	Distortion for high limit at time of stereo is poor	PLL construction not proble	—
C ₂₀₉	2200pF			Narrower capture range	
C ₂₀₇	3.3μF	L.P.F. of lamp circuit	Distortion for low limit is poor	Deterioration in lamp turn on and off response	—
C ₂₁₀	0.47μF	L.P.F. of PLL loop	Distortion for high limit at time of stereo is poor	Narrower capture range	—
C ₂₁₁	3.3μF				
R ₂₀₈	1kΩ				
C ₂₁₃	0.047μF	DC cut-off of PLL input	Poor selectivity	—	—
C ₂₁₂	1500pF	Correction of PLL phase delay	Insufficient pilot cancel	Insufficient pilot cancel	—
R ₂₁₁	100Ω	Prevention of poor S/N	S/N is at to become worse	Deterioration of low voltage characteristics	Note

Note: R₂₁₁ is inserted for the prevention of S/N from becoming worse. Since S/N will get worse when AC GND is performed to R₂₁₁ and pin 1, do not remove the AC GND from pin 1.

■ CAUTION

1. Handling of R_{211}

The R_{211} of block diagram is inserted for the prevention of deterioration. When using R_{211} , if AC GND is performed between R_{211} and pin 7, S/N will become worse to the extent of about 10dB when the temperature is low. And, when R_{211} is not inserted, S/N also becomes worse to the extent of about 10dB. So, in all cases be sure to insert R_{211} .

2. Adjustment of Pilot Cancel

As is seen on the block diagram, the pilot cancel of HA11223 employs a special method which make it cancel by the input from the decoder. During this time, since the signal for cancellation uses triangular waves, the input signal which passes through the pilot cancel circuit includes odd high harmonics of 19 kHz. The including 19 kHz is regenerated by this odd high harmonic wave and by the 38 kHz switching waves of the decoder. Since this regenerated signal of 19 kHz becomes unbalanced at L-ch and R-ch, it is necessary to adjust the pilot cancel by VR_{102} (100 k Ω) to make L-ch and R-ch the same. Also, when the unbalance between L-ch and R-ch is liable to generate when the phase difference between the input signal and the 19 kHz triangular waves for cancellation becomes larger. However, it is necessary to correct the phase by C_{212} (1500pF) to prevent it.

3. Forced Monaural

In order to put monaural in operation by HA11223, be sure to turn off the impressed voltage of pin 8 (lamp driver output terminal).

Therefore, Q_{101} and Q_{102} (2SC458) are used to force the monaural to operate.

As in the case of application of our IC HA1156W, when the method of making DC's GND pin 11 pin 8 for HA1156W is employed, the pilot circuit does not operate at the time of forced monaural. Moreover, it will generate a large popping noise, at the time of Stereo/Monaural changeover.

4. Adjustment of V.C.O. Free Running Frequency

Adjust the V.C.O. free running frequency by VR_{101} (3.3 k Ω) after the forced monaural is turned off and pin 2 is kept to have no input. Since the monitor of the free running frequency has no terminal, for exclusive use, a buffer amplifier of a high input impedance (Over 500 k Ω) should be provided through 220 k Ω from the point connection R_{206} (5.6 k Ω) to VR_{101} and then connecting to the frequency counter.

5. L.P.F. Within PLL

L.P.F. which is placed inside PLL of HA11223 is of a 2 stage construction. One is constructed by (C_{210} , C_{211} , and R_{208}) and the other is constructed by (C_{209} and R_{207}). Since the characteristics are influenced by both of the above mentioned two L.P.F. stages, in case a constant for L.P.F. is changed, be sure to thoroughly examine the relations between the two L.P.F. stages.

● L.P.F. for Carrier Leak Attenuation

Since HA11223 has a built-in pilot cancel circuit, it is possible to improve the f characteristics as compared with the L.P.F. previously used in general. Please take special note of the following matters concerning the above L.P.F.

1. Two Pole Type L.P.F.

L.P.F. of this type is used for comparatively sophisticated sets, however, in this case, it is considered necessary to make the attenuation quantity of the high limits smaller and also take sufficient carrier leak quantity.

In order to meet these demands, we recommend L.P.F. (Toko Trial Manufacture No. 190 BLR-3190N). The frequency characteristics of L.P.F. versus the attenuation degree characteristics are indicated on external parts. The following can be seen from the data,

- 1) Quantity of attenuation at f = 16 kHz: 0.20dB
- 2) Quantity of attenuation at f = 19 kHz: 13dB
- 3) Quantity of attenuation at f = 38 kHz: 50dB

On the other hand, the carrier leak (including Deemphasis) is 61dB typ. at 19 kHz, and is 35dB typ. at 38 kHz. Therefore, the composite carrier leak becomes as follows.

- 1' $13 + 61 = 74\text{dB typ. at } 19 \text{ kHz}$
- 2' $35 + 49 = 84\text{dB typ. at } 38 \text{ kHz}$

2. One Pole Type L.P.F.

An L.P.F. of this type is used for comparatively low price sets. In this case, the merits of the cost factor outweighs all other factors.

We recommend L.P.F. (Toko Trial Manufacture No. BLRB-3220N). The frequency vs. attenuation characteristics of this L.P.F. is indicated on curve. The following can be seen from the data.

- (1) Quantity of attenuation at f 15 kHz: 0.2dB
- (2) Quantity of attenuation at f 19 kHz: 3.5dB
- (3) Quantity of attenuation at f 38 kHz: 55dB

Accordingly, the composite carrier leak combined with the carrier leak characteristics of HA11223 becomes as follows.

- 1' $3.5 - 61 = 64.5\text{dB typ. at } 19 \text{ kHz}$
- 2' $55 - 35 = 90\text{dB typ. at } 38 \text{ kHz}$

This carrier leak characteristics is about the same as the characteristics of the 2 pole type L.P.F. used for the conventional IC for MPX.

3. 2 POLE TYPE LEAK FILTER

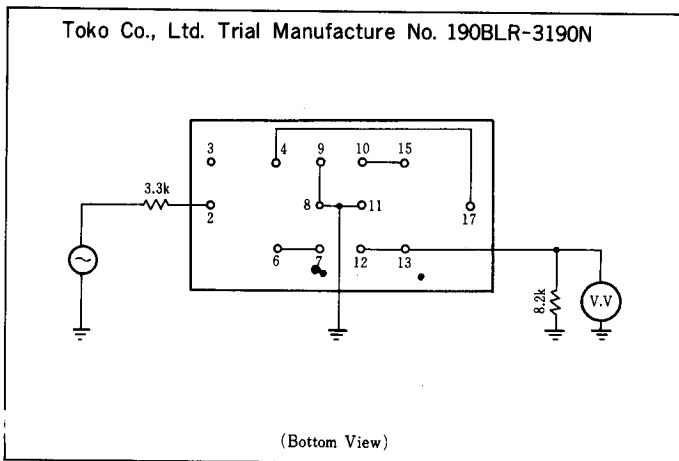

4. 1 POLE TYPE LEAK FILTER

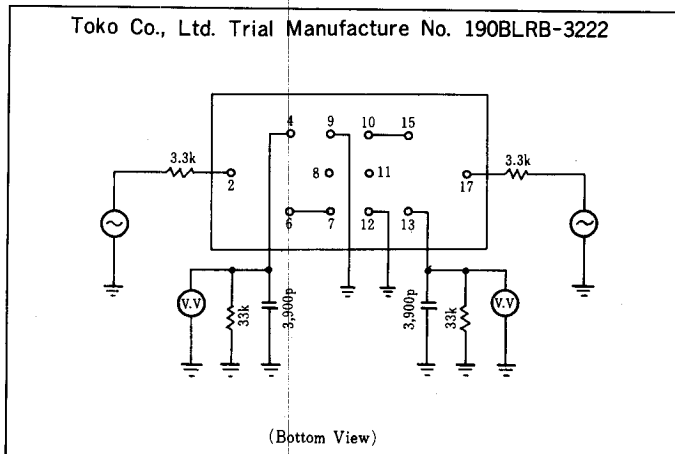

LEAK FILTER ATTENUATION VS. FREQUENCY

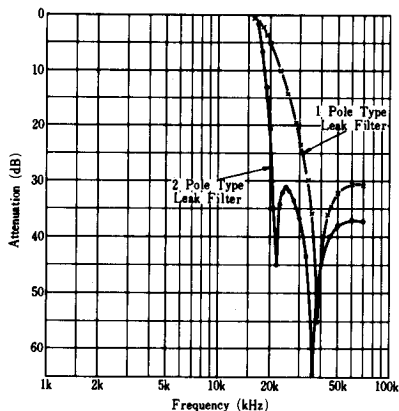

circuit is detected synchronously by the 19 kHz signal with the same phase as the pilot signal generated by the PLL circuit, and sent to pin 10 and pin 11 as a DC signal in proportion to the level of the pilot signal.

The DC signal is amplified by DC-Amp, and used as the control signal of the above mentioned Gain Control Amp. Therefore, when there is no load capacity C_{206} in the output of pin 9 that has been outputted from the Gain Control Amp.,

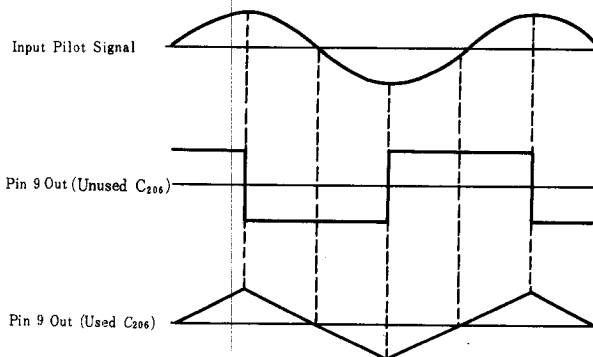

a rectangle wave with a phase of 90° advanced as compared with the input pilot signal will appear as indicated in the right figure b.

As a matter of fact, however, since there is C_{206} , a triangular wave that is in the same phase as the input pilot signal will appear as shown in Fig. c. The level of the triangular wave correlates with the input pilot signal level and it disperses due to dispersion of IC within the circuit. Therefore, it is necessary to adjust properly the level by VR_{102} (100 k Ω B). This level adjusted triangular wave is inputted to pin 4 and is phase inverted by Q_{60} , then added to the input pilot signal.

EXPLANATION OF OPERATIONS

Features of IC

1. Built-in pilot cancel circuit.
2. Reduction of beat generated at the time of stereo highpass input, a problem that has been common with the conventional ICs.
3. Low distortion
4. High S/N

We will explain the improvements of the above circuit.

1. Pilot Cancel Circuit Operations

The composite signal inputted from pin 2 is amplified by the Pre-Amp circuit, and then it is outputted to pin 3. This signal is inputted to pin 12 and, one part is inputted to the PLL circuit and the other to the lamp driver circuit. The PLL circuit locks out the pilot signal by the signal which has been inputted to the PLL circuit, and the signal in the PLL circuit generates three kinds of signals, 76 kHz, 38 kHz, and 19 kHz. The 19 kHz signal whose phase is advancing 90° more than the pilot signal is inputted to the Gain Control Amp.

On the other hand, the signal inputted to the lamp driver

Since the pilot cancel of HA11223 is utilizing the above mentioned triangular wave injection, when the difference between the pilot signal and the fundamental frequency component of the triangular wave is eliminated, the odd high harmonics of the triangular wave will remain.

This high harmonic components are, needless to say, the odd times of 19 kHz, but when this signal is turned on by switching TRS (Q_{50} to Q_{53}) of the decoder, as the 38 kHz rectangular wave, it causes beat with the high harmonics that are the odd times of 38 kHz, and generates a signal of 19 kHz component again.

As a result of this, the signal of 19 kHz component that appears at the output pin becomes easier to be unbalanced at pin ⑤ and at pin ⑥. Therefore, for the above mentioned adjustments of VR_{102} , it becomes necessary to make each 19 kHz component appearing at pin ⑤ and at pin ⑥ the same and to maximize them.

2. Reduction Circuit for Beat Caused at Stereo High-Frequency Input

In the case of the MPX of the conventional PLL, the beat of $f = 1$ kHz at an input of $f = 10$ kHz during stereo operations will become larger by as much as 0.3 to 0.5% through the T.H.D. This is due to the phase comparator. Since the bit

generated with the high harmonics of the main signal and the 19 kHz switching signal is not attenuated by the L.P.F. which is placed between the phase comparator and the DC-Amp. of the second stage, V.C.O. is modulated by the beat.

For prevention of this, the L.P.F. is provided at 2 levels to sufficiently attenuate the beat. Through these countermeasures it has become possible to reduce the beat generated with the 10 kHz main signal input to such a degree as about 0.06% by the T.H.D. conversion.

3. Low Distortion

The HA11223 provides 100% negative amplification of the block generating distortion by the decoder to obtain a low distortion.

In addition, the reference voltage circuit of the amplifier of the same type is used to obtain a good balance of the decoder.

As the result, the HA11223 monaural distortion becomes 0.01% typ.

4. High S/N

The HA11223 pays particular attention to the circuit whose noise sensitivity is high at the MPX decoder and provides a low sensitivity to noises. Therefore, it becomes 86dB typ. at monaural S/N.

■ PC-BOARD LAYOUT PATTERN

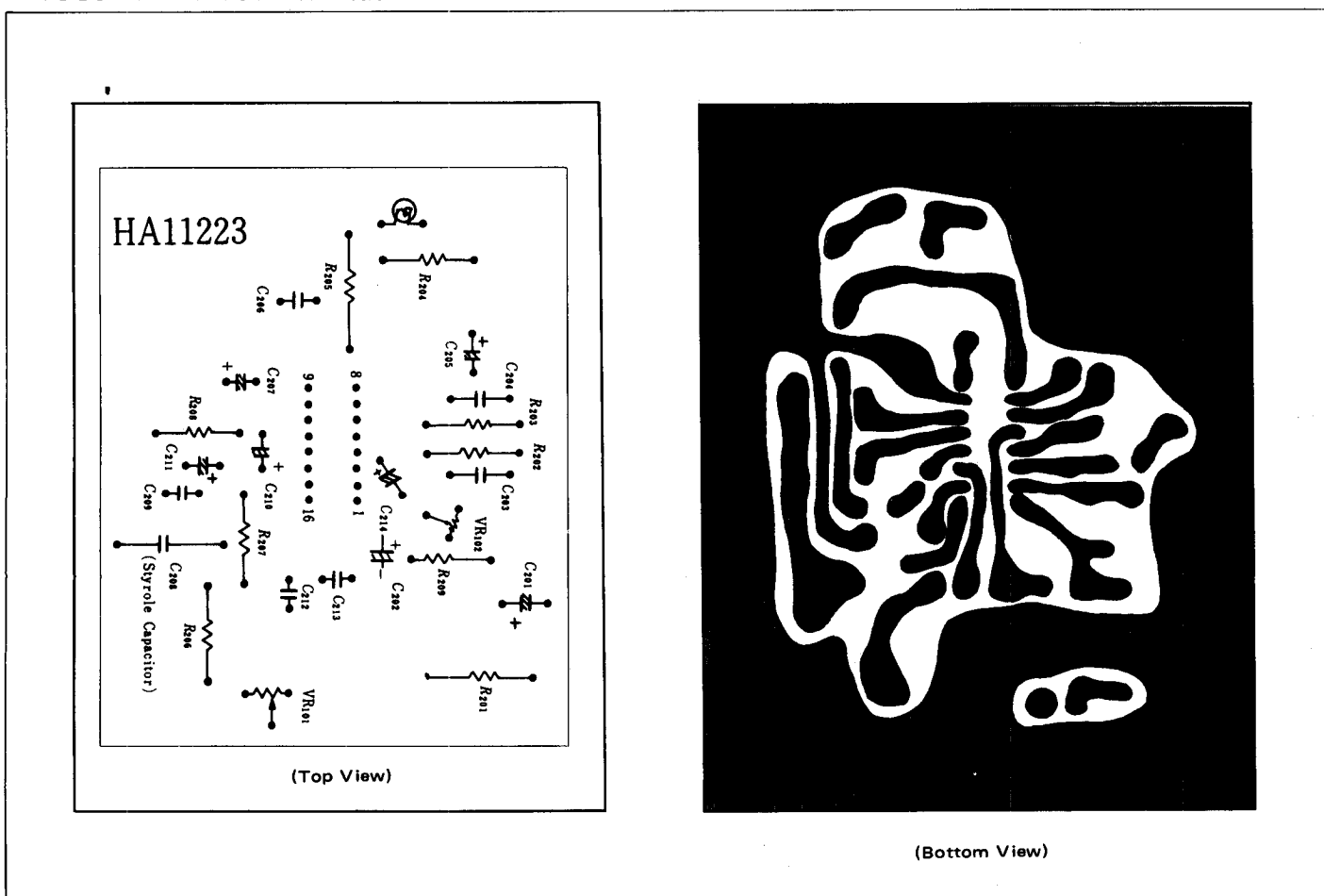

CHANNEL BALANCE, R-CHANNEL OUTPUT VOLTAGE AND TOTAL HARMONIC DISTORTION VS. FREQUENCY

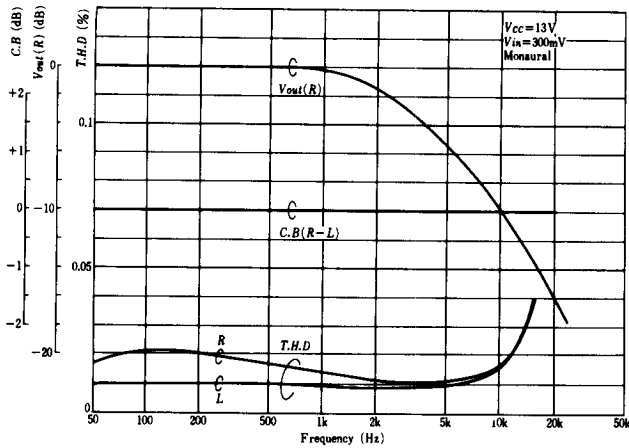

SEPARATION AND TOTAL HARMONIC DISTORTION VS. FREQUENCY

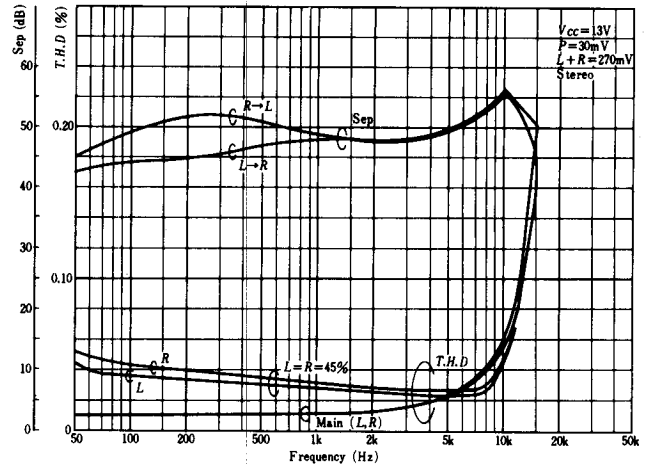

SEPARATION AND TOTAL HARMONIC DISTORTION VS. INPUT VOLTAGE

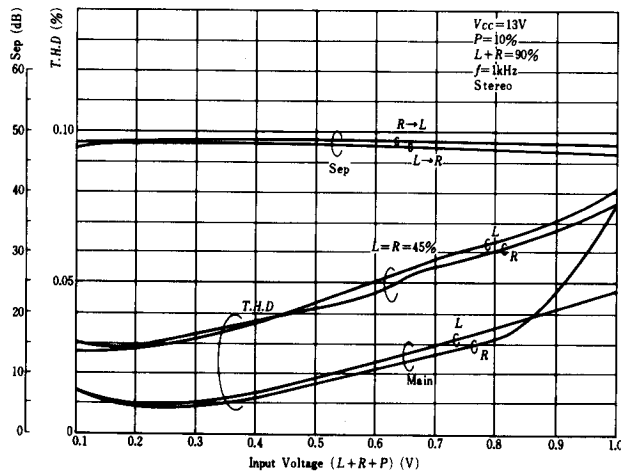

CHANNEL BALANCE, OUTPUT VOLTAGE AND TOTAL HARMONIC DISTORTION VS. INPUT VOLTAGE

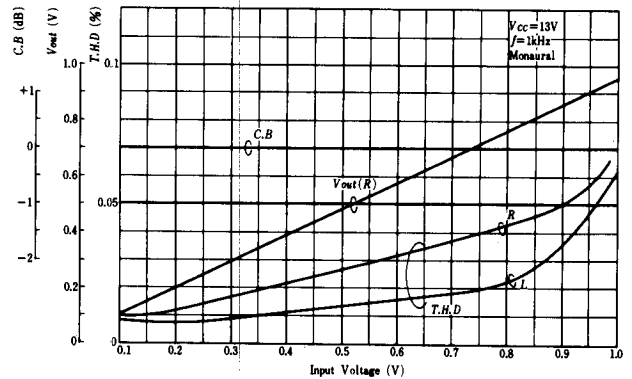

CARRIER LEAK VS. INPUT VOLTAGE

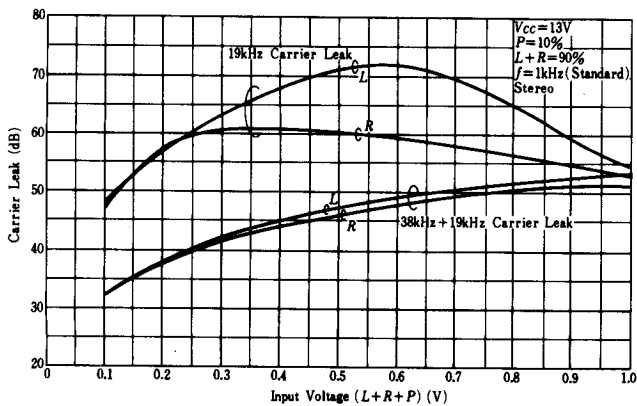

SCA REJECTION VS. FREQUENCY

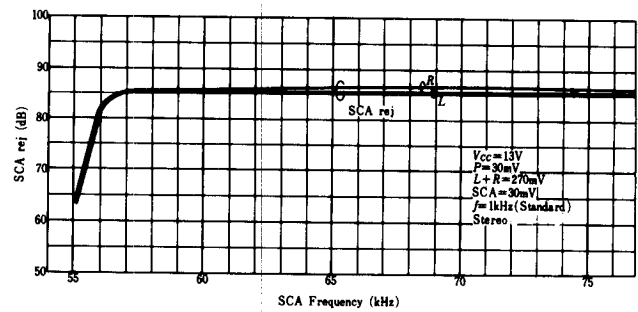

TOTAL HARMONIC DISTORTION, CARRIER LEAK AND SEPARATION VS. PILOT INPUT LEVEL

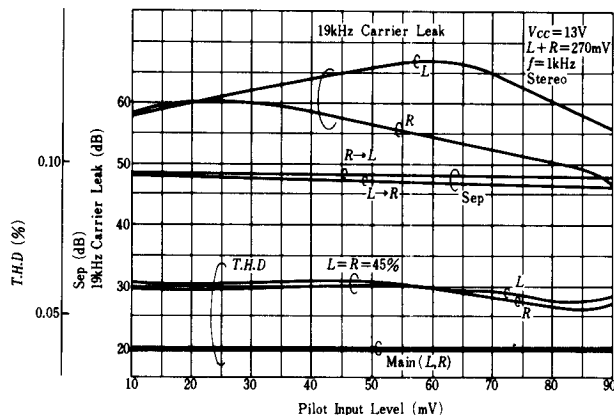

SEPARATION AND TOTAL HARMONIC DISTORTION VS. V.C.O. FREE RUNNING FREQUENCY DRIFT

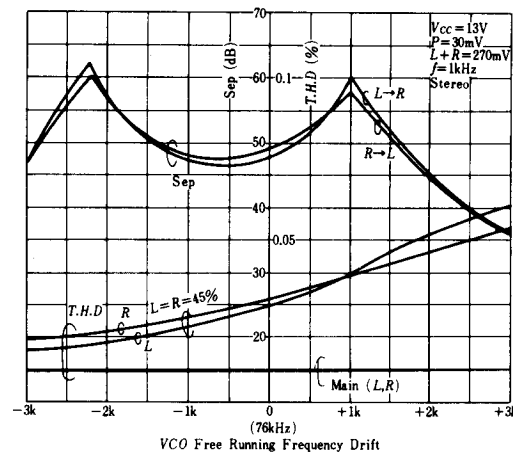

PILOT INPUT LEVEL AND CARRIER LEAK VS. V.C.O. FREE RUNNING FREQUENCY DRIFT

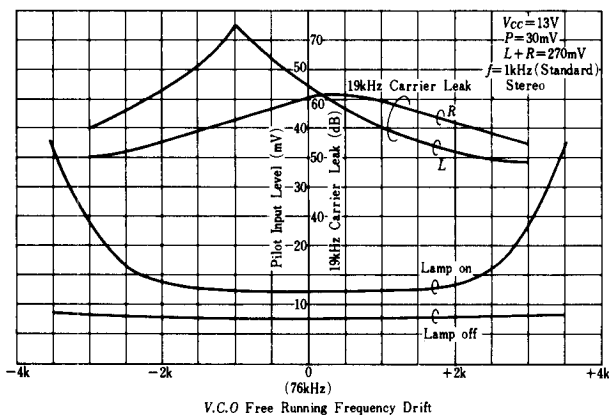

TOTAL HARMONIC DISTORTION AND SEPARATION VS. SUPPLY VOLTAGE

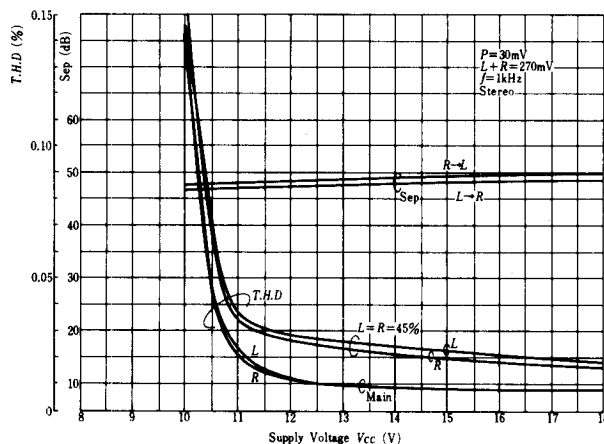

V.C.O. FREE RUNNING FREQUENCY DRIFT AND LAMP ON/OFF LEVEL VS. SUPPLY VOLTAGE

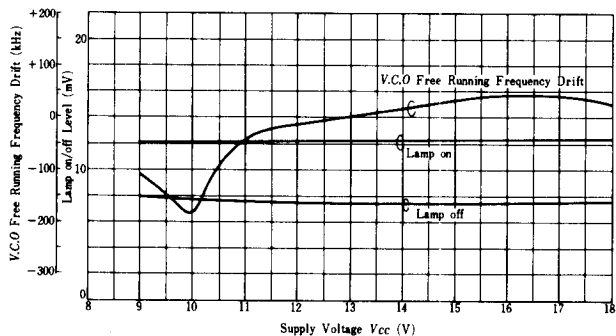

SIGNAL-TO-NOISE RATIO, CANNEL BALANCE, OUTPUT VOLTAGE AND TOTAL HARMONIC DISTORTION VS. SUPPLY VOLTAGE

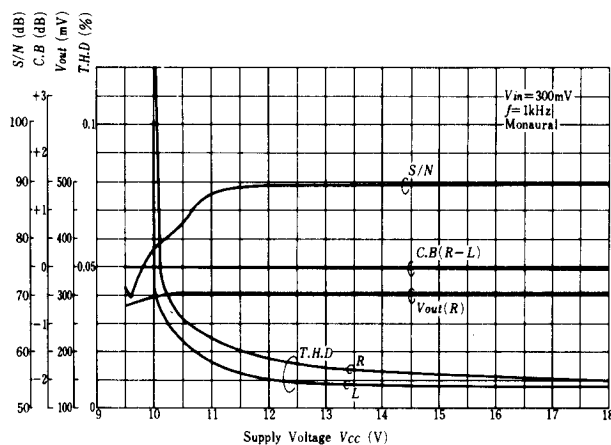

SCA REJECTION VS. SUPPLY VOLTAGE

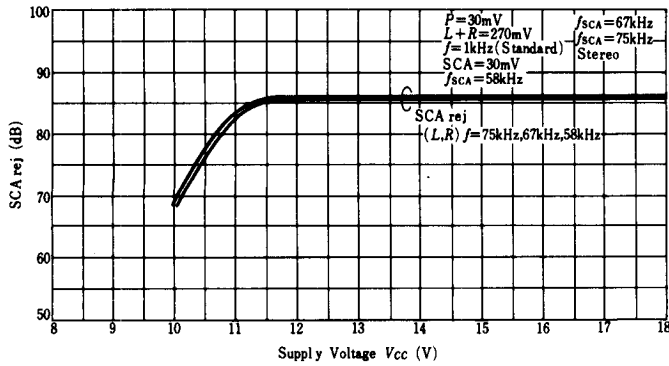

SCA REJECTION AND SEPARATION VS. AMBIENT TEMPERATURE

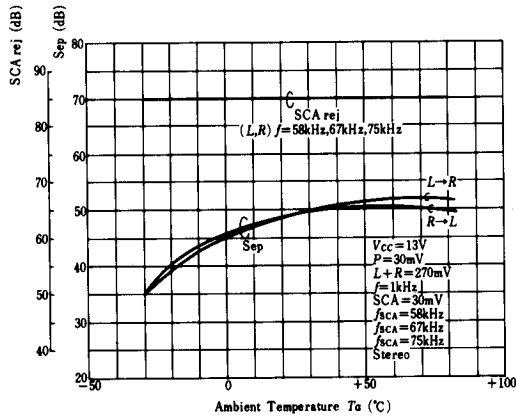

SIGNAL-TO-NOISE RATIO, CHANNEL BALANCE, TOTAL HARMONIC DISTORTION AND OUTPUT VOLTAGE VS. AMBIENT TEMPERATURE

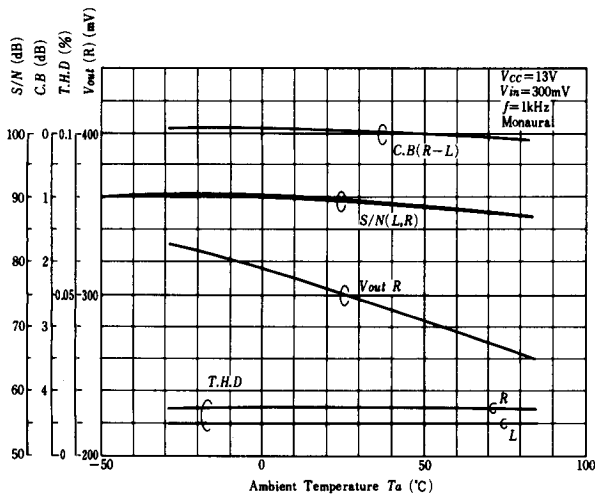

SIGNAL-TO-NOISE RATIO AND TOTAL HARMONIC DISTORTION VS. AMBIENT TEMPERATURE

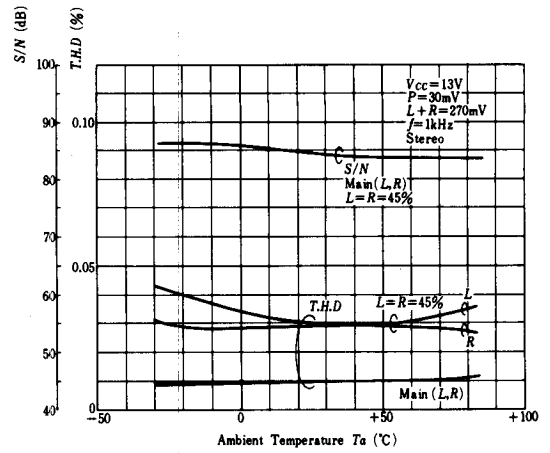

FREE RUNNING FREQUENCY AND CARRIER LEAK VS. AMBIENT TEMPERATURE

