

HA13122

Dual 4 W Audio Power Amplifier

T-74-05-01

The HA13122 is specifically designed for cassette-radio, encapsulated in SP-15TA plastic package. The HA13122 delivers 4.3 W per channel under 12 V power supply to 4 Ω load.

Features

- A low quiescent current (36 mA typ.) for efficient battery-operation
- Designed for low crossover distortion under a low idling current
- Audio muting circuit included, providing 60 dB typ of muting attenuation just by 5 mA of muting control current
- No electrical isolation needed for simple chassis-mounting
- Dual power amplifiers provide 4.3 W typ. under 12 V power supply voltage ($R_L = 4 \Omega$, THD = 10 %)
- Internal thermal protection

Ordering Information

Type No.	Package
HA13122	SP-15



Hitachi America, Ltd. • Hitachi Plaza • 2000 Sierra Point Pkwy. • Brisbane, CA 94005-1819 • (415) 589-8300 361

HA13122

T-74-05-01

Recommended Application

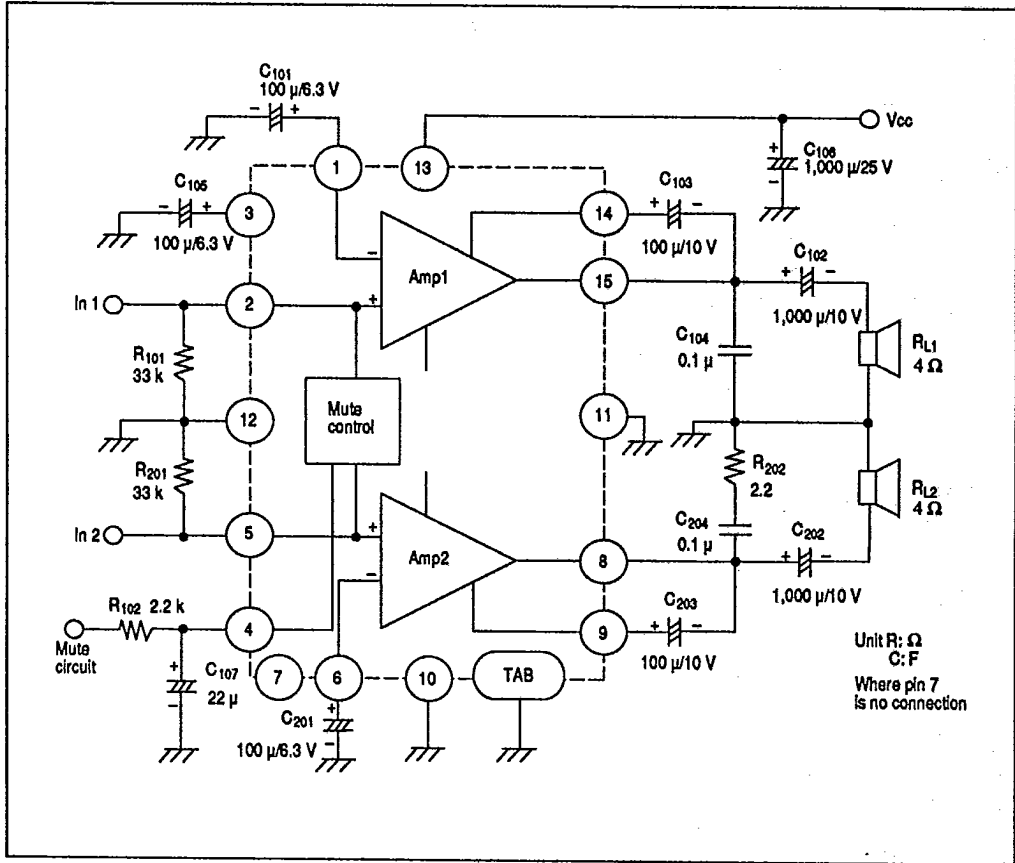

362 Hitachi America, Ltd. • Hitachi Plaza • 2000 Sierra Point Pkwy. • Brisbane, CA 94005-1819 • (415) 589-8300

T-74-05-01

HA13122

Table 1 Absolute Maximum Ratings (Ta = 25 °C)

Item	Symbol	Rating	Unit
Supply voltage	Vcc	18	V
Output current	Io(peak)	4	A
Power dissipation	Pr	15 (See note)	W
Junction temperature	Tj	150	°C
Operating temperature	Topr	-20 to +70	°C
Storage temperature	Tstg	-50 to +125	°C

Note: The derating curve is shown below, in which θ is the thermal resistance of heat - sink. θ_j-c , the thermal resistance between the junction and the case (TAB), is calculated as 4 °C/W.

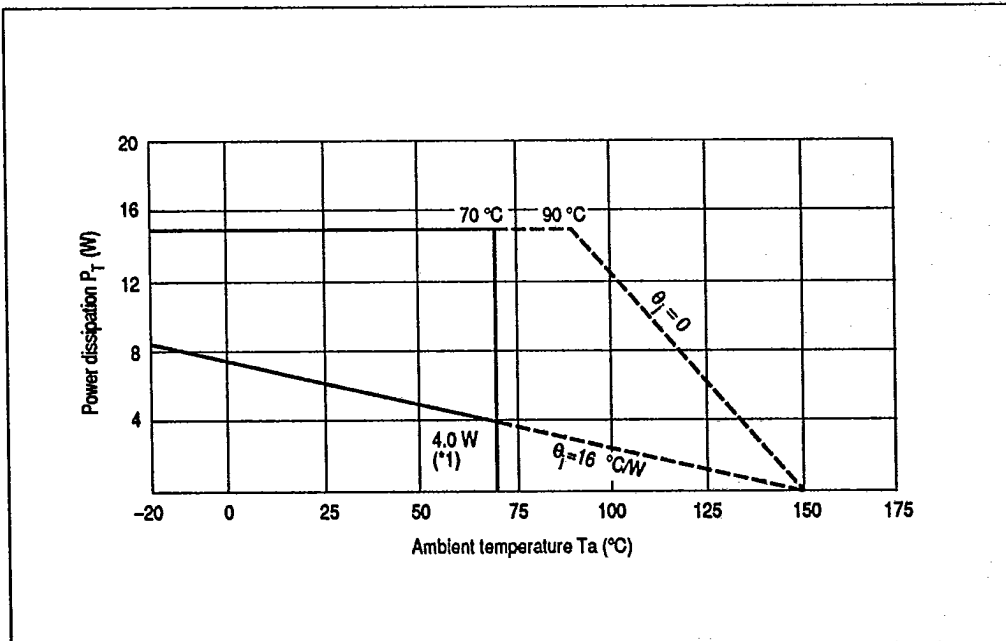

*1: Max power dissipation under Vcc = 12 V, RL = 4 Ω and dual operation.



Hitachi America, Ltd. • Hitachi Plaza • 2000 Sierra Point Pkwy. • Brisbane, CA 94005-1819 • (415) 589-8300 363

HA13122

T-74-05-01

Table 2 Electrical Characteristics (Unless otherwise specified, $T_a = 25^\circ\text{C}$, $V_{CC} = 12\text{ V}$, $R_L = 4\ \Omega$, $f = 1\text{ kHz}$ and $R_g = 600\ \Omega$, under Dual Amp Operation)

Item	Symbol	Min	Typ	Max	Unit	Test Conditions
Quiescent current	I_Q	—	36	60	mA	$V_{in} = 0\text{ V}$
Input bias current	I_B	—	—	1.0	μA	$V_{in} = 0\text{ V}$
Voltage gain	G_v	44	46	48	dB	$V_{in} = -46\text{ dBm}$
Difference of voltage gain	ΔG_v	—	—	± 1.5	dB	$V_{in} = -46\text{ dBm}$
Output power per channel	P_{out}	3.8	4.3	—	W	THD = 10 % $V_{CC} = 12\text{ V}$
Total harmonic distortion	THD	—	0.25	1.0	%	$P_{out} = 0.5\text{ W}$
Noise output	WBN	—	0.4	1.0	mV	$R_g = 10\text{ k}\Omega$, BW = 20 Hz to 20 kHz
Supply voltage rejection ratio	SVR	40	44	—	dB	$f = 100\text{ Hz}$, Vripple = 0 dBm
Roll-off frequency	f_H	12	20	33	kHz	$V_{in} = -46\text{ dBm}$, $G_v = -3\text{ dB}$ ($f = 1\text{ kHz Ref.}$)
Cross-talk	CT	—	60	—	dB	$V_{in} = -46\text{ dBm}$
Muting attenuation	ATT	—	60	—	dB	$I_{MUTE} = 5\text{ mA}$, $V_{in} = -46\text{ dBm}$



Typical Performance Curves

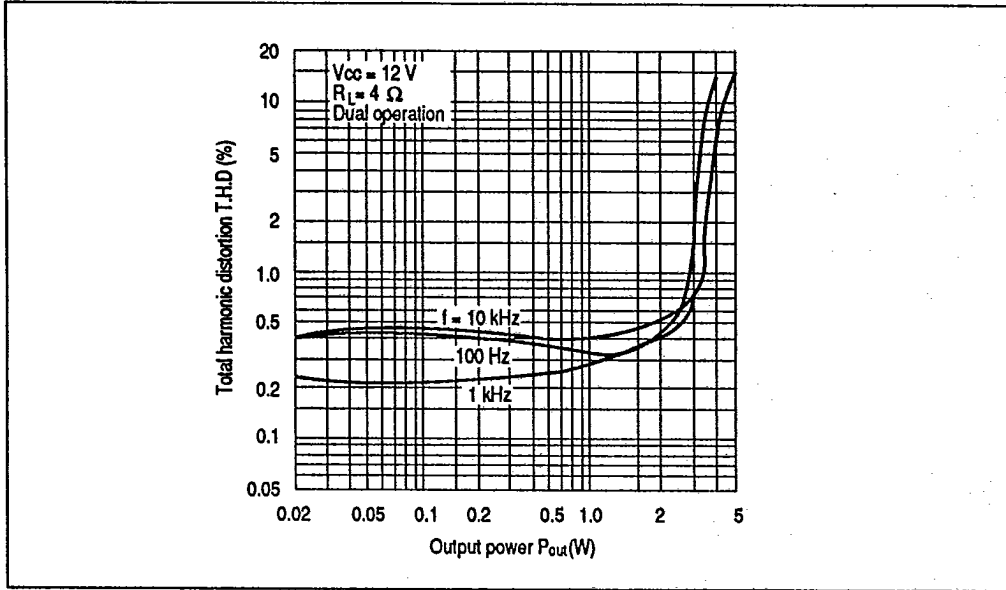

Total Harmonic Distortion vs. Output Power

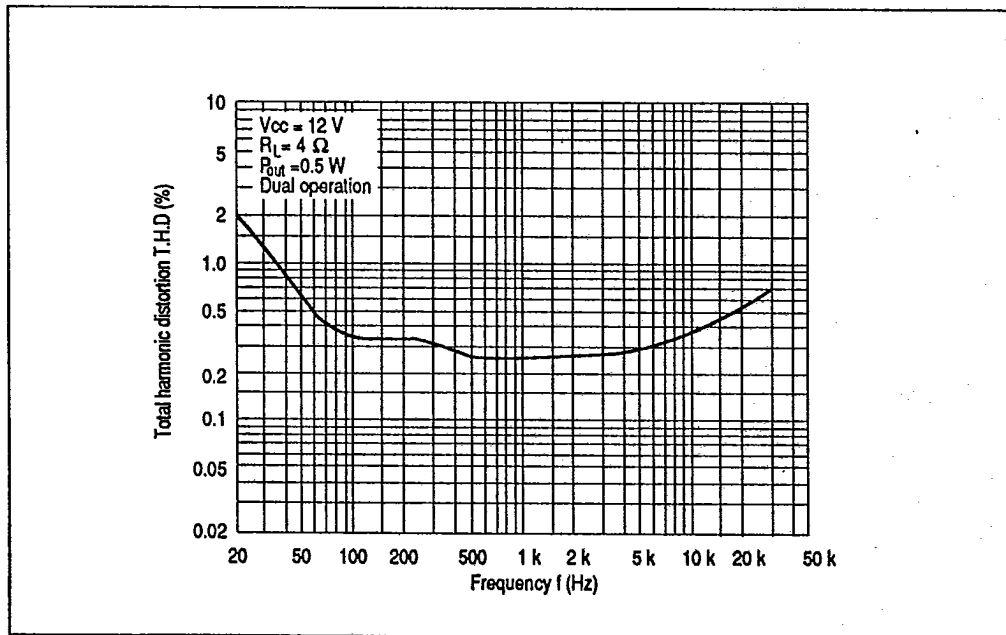

Total Harmonic Distortion vs. Frequency



Hitachi America, Ltd. • Hitachi Plaza • 2000 Sierra Point Pkwy. • Brisbane, CA 94005-1819 • (415) 589-8300 365

HA13122

T-74-05-01

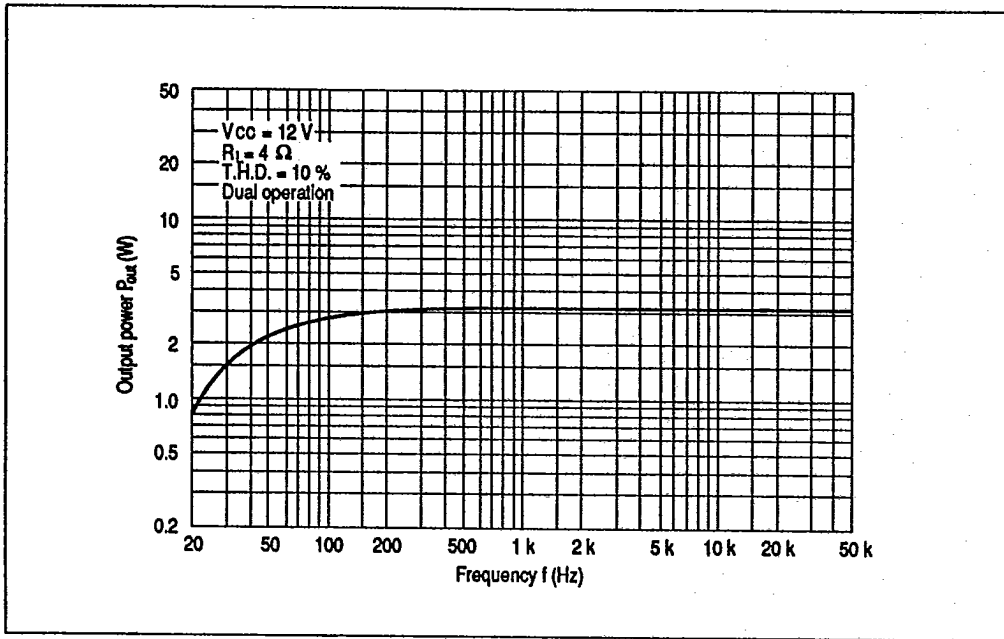

Output Power vs. Frequency

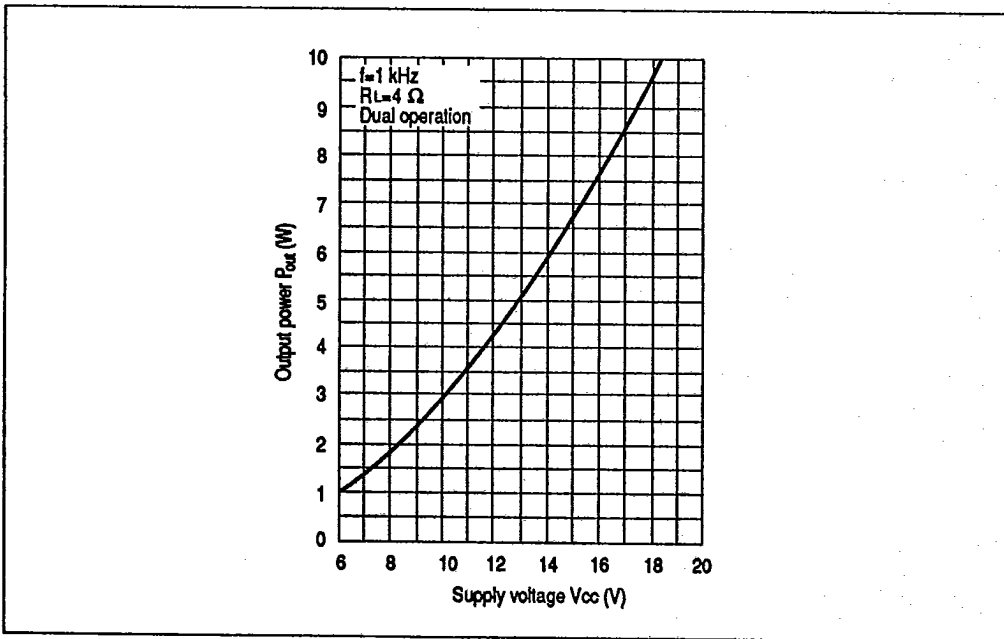

Output Power vs. Supply Voltage



T-74-05-01 HA13122

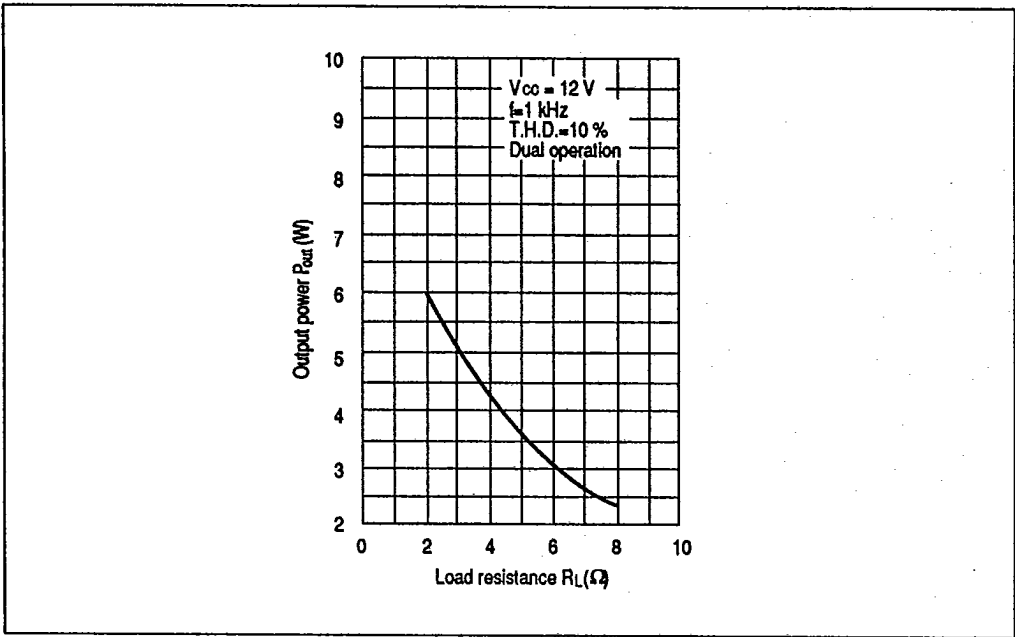

Output Power vs. Load Resistance

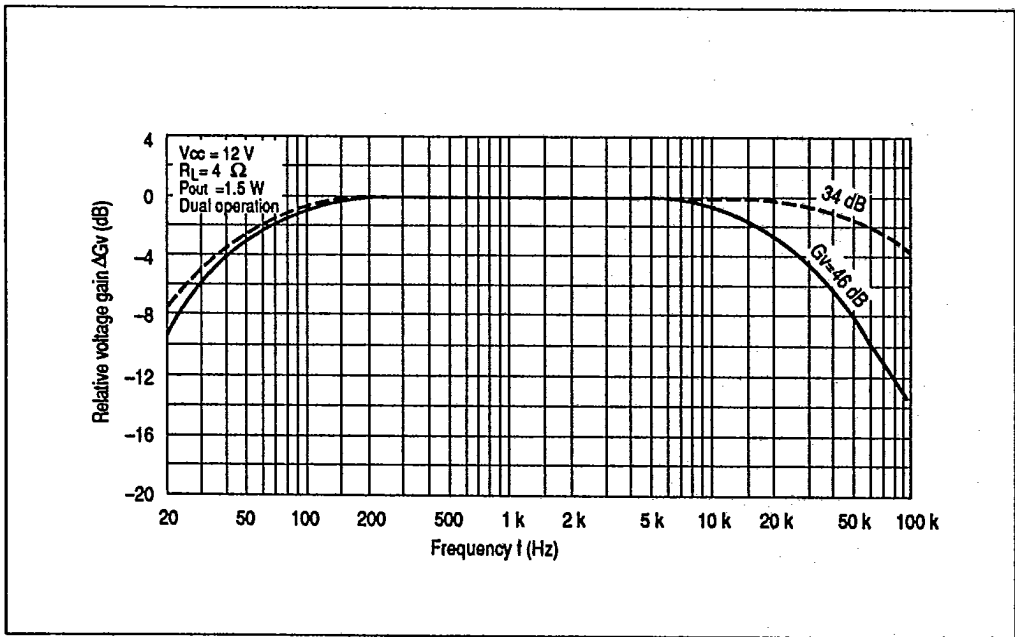

Relative Voltage Gain vs. Frequency



Hitachi America, Ltd. • Hitachi Plaza • 2000 Sierra Point Pkwy. • Brisbane, CA 94005-1819 • (415) 589-8300