HD74AC245/HD74ACT245

Octal Bidirectional Transceiver with 3-State Input/Output

HITACHI

Description

The HD74AC245/HD74ACT245 contains eight non-inverting bidirectional buffers with 3-state outputs and is intended for bus-oriented applications. Current sinking capability is 24 mA at both the A and B ports. The Transmit/Receive (T/\bar{R}) input determines the direction of data flow through the bidirectional transceiver. Transmit (active-High) enables data from A ports to B ports; Receive (active-Low) enables data from B ports to A ports. The Output Enable input, when High, disables, both A and B ports by placing them in a High Z condition.

Features

- Noninverting Buffers
- Bidirectional Data Path
- A and B Outputs Source/Sink 24 mA
- HD74ACT245 has TTL-Compatible Inputs

Pin Names

\overline{OE}	Output Enable Input
T/\bar{R}	Transmit/Receive Input
A_0 to A_7	Side A 3-State Inputs or 3-State Outputs
B_0 to B_7	Side B 3-State Inputs or 3-State Outputs

HD74AC245/HD74ACT245

Pin Arrangement

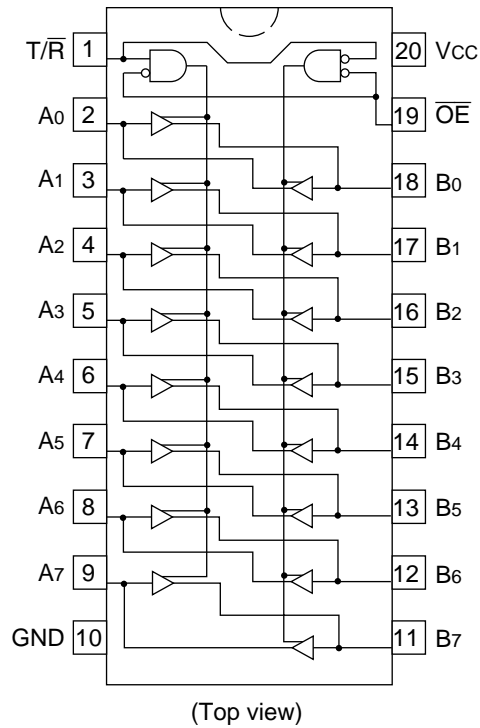

Truth Tables

Inputs

\overline{OE}	T/\overline{R}	Outputs
L	L	Bus B Data to Bus A
L	H	Bus A Data to Bus B
H	X	High Z State

H : High Voltage Level

L : Low Voltage Level

X : Immaterial

HITACHI

DC Characteristics (unless otherwise specified)

Item	Symbol	Max	Unit	Condition
Maximum quiescent supply current	I_{CC}	80	μA	$V_{IN} = V_{CC}$ or ground, $V_{CC} = 5.5\text{ V}$, $T_a = \text{Worst case}$
Maximum quiescent supply current	I_{CC}	8.0	μA	$V_{IN} = V_{CC}$ or ground, $V_{CC} = 5.5\text{ V}$, $T_a = 25^\circ\text{C}$
Maximum additional I_{CC}/input (HD74ACT245)	I_{CCT}	1.5	mA	$V_{IN} = V_{CC} - 2.1\text{ V}$, $V_{CC} = 5.5\text{ V}$, $T_a = \text{Worst case}$

AC Characteristics: HD74AC245

Item	Symbol	$V_{CC} (\text{V})^{*1}$	$T_a = +25^\circ\text{C}$ $C_L = 50\text{ pF}$			$T_a = -40^\circ\text{C to } +85^\circ\text{C}$ $C_L = 50\text{ pF}$		Unit
			Min	Typ	Max	Min	Max	
Propagation delay	t_{PLH}	3.3	1.0	5.0	8.5	1.0	9.0	ns
		5.0	1.0	3.5	6.5	1.0	7.0	
Data to output	t_{PHL}	3.3	1.0	5.0	8.5	1.0	9.0	ns
		5.0	1.0	3.5	6.0	1.0	7.0	
Output enable time	t_{PZH}	3.3	1.0	7.0	11.5	1.0	12.5	ns
		5.0	1.0	5.0	8.5	1.0	9.0	
Output enable time	t_{PZL}	3.3	1.0	7.5	12.0	1.0	13.5	ns
		5.0	1.0	5.5	9.0	1.0	9.5	
Output disable time	t_{PHZ}	3.3	1.0	6.5	12.0	1.0	12.5	ns
		5.0	1.0	5.5	9.0	1.0	10.0	
Output disable time	t_{PLZ}	3.3	1.0	7.0	11.5	1.0	13.0	ns
		5.0	1.0	5.5	9.0	1.0	10.0	

Note: 1. Voltage Range 3.3 is $3.3\text{ V} \pm 0.3\text{ V}$
Voltage Range 5.0 is $5.0\text{ V} \pm 0.5\text{ V}$

HD74AC245/HD74ACT245

AC Characteristics: HD74ACT245

Item	Symbol	V _{CC} (V)*1	Ta = +25°C C _L = 50 pF			Ta = -40°C to +85°C C _L = 50 pF		Unit
			Min	Typ	Max	Min	Max	
Propagation delay Data to output	t _{PLH}	5.0	1.0	4.0	7.5	1.0	8.0	ns
Propagation delay Data to output	t _{PHL}	5.0	1.0	4.0	8.0	1.0	9.0	ns
Output enable time	t _{PZH}	5.0	1.0	5.0	10.0	1.0	11.0	ns
Output enable time	t _{PZL}	5.0	1.0	5.5	10.0	1.0	12.0	ns
Output disable time	t _{PHZ}	5.0	1.0	5.5	10.0	1.0	11.0	ns
Output disable time	t _{PLZ}	5.0	1.0	5.0	10.0	1.0	11.0	ns

Note: 1. Voltage Range 5.0 is 5.0 V ± 0.5 V

Capacitance

Item	Symbol	Typ	Unit	Condition
Input capacitance	C _{IN}	4.5	pF	V _{CC} = 5.5 V
Input/output capacitance	C _{I/O}	15.0	pF	V _{CC} = 5.5 V
Power dissipation capacitance	C _{PD}	45.0	pF	V _{CC} = 5.0 V

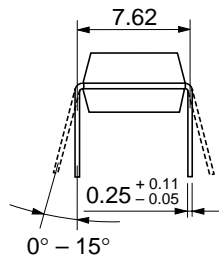
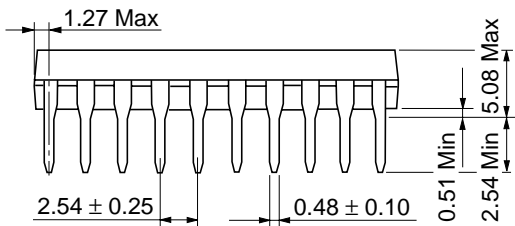
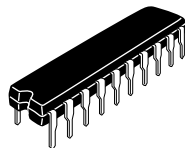
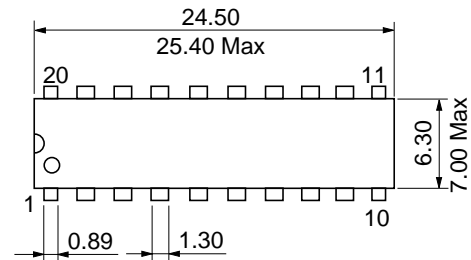

Hitachi Code	DP-20N
JEDEC	—
EIAJ	Conforms
Weight (reference value)	1.26 g

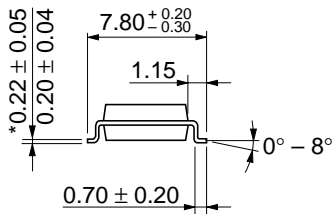
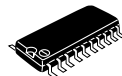
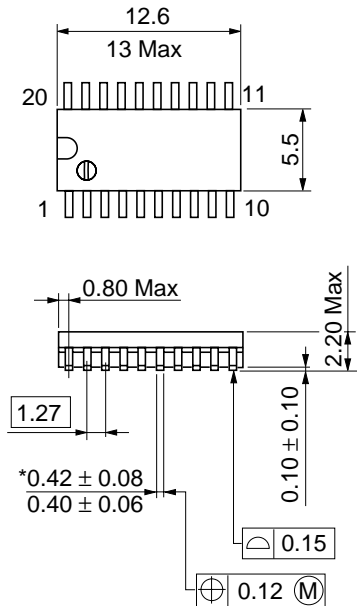

*Dimension including the plating thickness
Base material dimension

Hitachi Code	FP-20DA
JEDEC	—
EIAJ	Conforms
Weight (reference value)	0.31 g

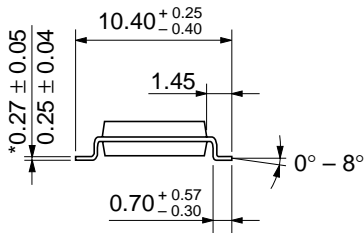
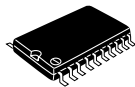
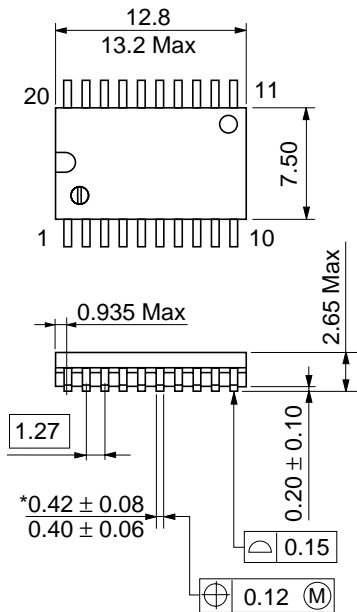

Hitachi Code	FP-20DB
JEDEC	Conforms
EIAJ	—
Weight (reference value)	0.52 g

*Dimension including the plating thickness
Base material dimension

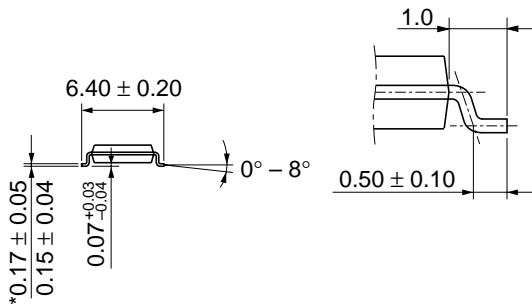
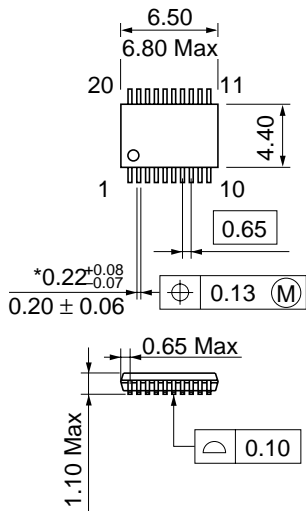

*Dimension including the plating thickness
Base material dimension

Hitachi Code	TTP-20DA
JEDEC	—
EIAJ	—
Weight (reference value)	0.07 g

Cautions

1. Hitachi neither warrants nor grants licenses of any rights of Hitachi's or any third party's patent, copyright, trademark, or other intellectual property rights for information contained in this document. Hitachi bears no responsibility for problems that may arise with third party's rights, including intellectual property rights, in connection with use of the information contained in this document.
2. Products and product specifications may be subject to change without notice. Confirm that you have received the latest product standards or specifications before final design, purchase or use.
3. Hitachi makes every attempt to ensure that its products are of high quality and reliability. However, contact Hitachi's sales office before using the product in an application that demands especially high quality and reliability or where its failure or malfunction may directly threaten human life or cause risk of bodily injury, such as aerospace, aeronautics, nuclear power, combustion control, transportation, traffic, safety equipment or medical equipment for life support.
4. Design your application so that the product is used within the ranges guaranteed by Hitachi particularly for maximum rating, operating supply voltage range, heat radiation characteristics, installation conditions and other characteristics. Hitachi bears no responsibility for failure or damage when used beyond the guaranteed ranges. Even within the guaranteed ranges, consider normally foreseeable failure rates or failure modes in semiconductor devices and employ systemic measures such as fail-safes, so that the equipment incorporating Hitachi product does not cause bodily injury, fire or other consequential damage due to operation of the Hitachi product.
5. This product is not designed to be radiation resistant.
6. No one is permitted to reproduce or duplicate, in any form, the whole or part of this document without written approval from Hitachi.
7. Contact Hitachi's sales office for any questions regarding this document or Hitachi semiconductor products.

HITACHI

Hitachi, Ltd.

Semiconductor & Integrated Circuits.
Nippon Bldg., 2-6-2, Ohte-machi, Chiyoda-ku, Tokyo 100-0004, Japan
Tel: Tokyo (03) 3270-2111 Fax: (03) 3270-5109

URL North America : <http://semiconductor.hitachi.com/>
 Europe : <http://www.hitachi-eu.com/hel/ecg>
 Asia (Singapore) : <http://www.has.hitachi.com.sg/grp3/sicd/index.htm>
 Asia (Taiwan) : http://www.hitachi.com.tw/E/Product/SICD_Frame.htm
 Asia (HongKong) : <http://www.hitachi.com.hk/eng/bo/grp3/index.htm>
 Japan : <http://www.hitachi.co.jp/Sicd/indx.htm>

For further information write to:

Hitachi Semiconductor
(America) Inc.
179 East Tasman Drive,
San Jose, CA 95134
Tel: <1> (408) 433-1990
Fax: <1> (408) 433-0223

Hitachi Europe GmbH
Electronic components Group
Dornacher Straße 3
D-85622 Feldkirchen, Munich
Germany
Tel: <49> (89) 9 9180-0
Fax: <49> (89) 9 29 30 00

Hitachi Europe Ltd.
Electronic Components Group.
Whitebrook Park
Lower Cookham Road
Maidenhead
Berkshire SL6 8YA, United Kingdom
Tel: <44> (1628) 585000
Fax: <44> (1628) 778322

Hitachi Asia Pte. Ltd.
16 Collyer Quay #20-00
Hitachi Tower
Singapore 049318
Tel: 535-2100
Fax: 535-1533

Hitachi Asia Ltd.
Taipei Branch Office
3F, Hung Kuo Building, No.167,
Tun-Hwa North Road, Taipei (105)
Tel: <886> (2) 2718-3666
Fax: <886> (2) 2718-8180

Hitachi Asia (Hong Kong) Ltd.
Group III (Electronic Components)
7/F., North Tower, World Finance Centre,
Harbour City, Canton Road, Tsim Sha Tsui,
Kowloon, Hong Kong
Tel: <852> (2) 735 9218
Fax: <852> (2) 730 0281
Telex: 40815 HITEC HX

Copyright ' Hitachi, Ltd., 1999. All rights reserved. Printed in Japan.

HITACHI