

**8.0A HIGH EFFICIENCY RECTIFIERS - 50V-1000V
TO-220A PACKAGE**

**HER801
THRU
HER808**

Features

- Low forward voltage drop
- High current capability
- High reliability
- High surge current capability
- High speed switching
- AEC-Q101 qualified
-
-



TO-220A

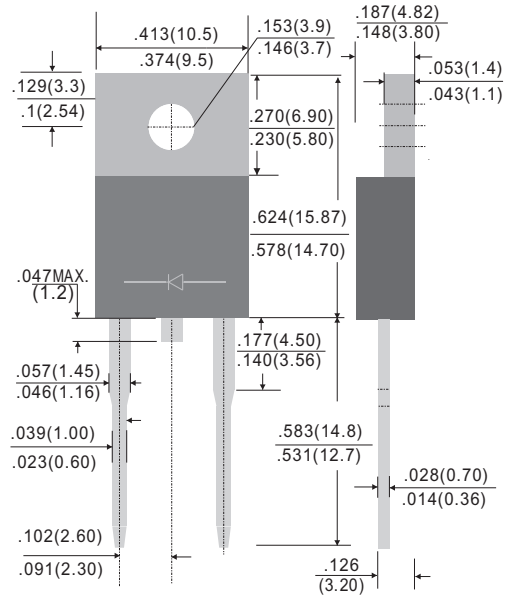

Dimensions in inches and (millimeters)

Mechanical Date

- Case: TO-220A
- Case Material: Molded Plastic. UL Flammability Classification Rating 94V-0
- Terminals: Lead Free Plating (Tin Finish). Solderable per MIL-STD-202, Method 208
- Weight: 1.89 grams (approximate)

MAXIMUM RATINGS (TA=25°C unless otherwise noted)

PARAMETER	SYMBOL	HER 801	HER 802	HER 803	HER 804	HER 805	HER 806	HER 807	HER 808	UNIT	
Maximum repetitive peak reverse voltage	V_{RRM}	50	100	200	300	400	600	800	1000	V	
Maximum RMS voltage	V_{RMS}	35	70	140	210	280	420	560	700	V	
Maximum DC blocking voltage	V_{DC}	50	100	200	300	400	600	800	1000	V	
Maximum average forward rectified current	I_F	8.0								A	
Peak forward surge current, 8.3ms single half sine-wave superimposed on rated load	I_{FSM}	125.0								A	
Maximum Instantaneous Forward Voltage IF=8A @ 25°C	V_F	1.00		1.35		1.75			V		
Maximum DC Reverse Current @ Tc=25°C at Rated DC Blocking Voltage @ Tc=100°C	I_R	10				20				uA mA	
Typical Junction Capacitance(NOTE1)	C_j	75								pF	
Maximum Reverse Recovery Time(NOTE2)	T_{rr}	50					75				ns
Typical Thermal Resistance	$R_{\theta JC}$	3								°C/W	
Operating Temperature Range	T_J	-55 to +150								°C	
Storage Temperature Range	T_{STG}	-55 to +150								°C	

NOTES: 1. Measured at 1.0MHZ and applied reverse voltage of 4.0V DC
2. Measured with IF=0.5A, IR=1A, IRR=0.25A

FIG. 1-TYPICAL FORWARD CURRENT DERATING CURVE

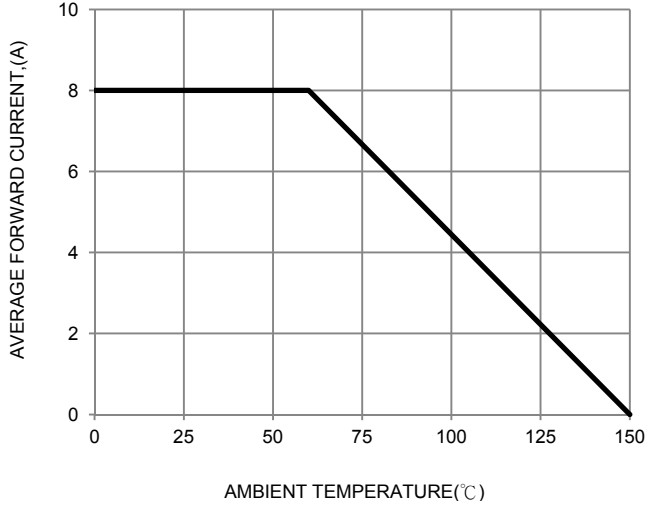

FIG. 2-TYPICAL FORWARD CHARACTERISTICS

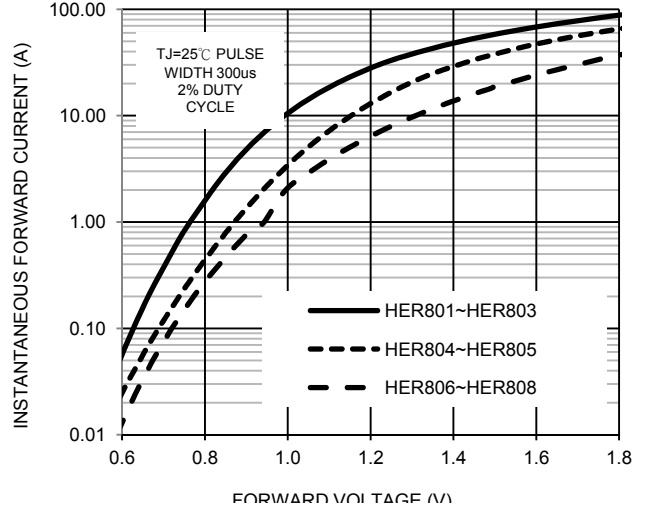

FIG. 3-MAXIMUM NON-REPETITIVE FORWARD SURGE CURRENT

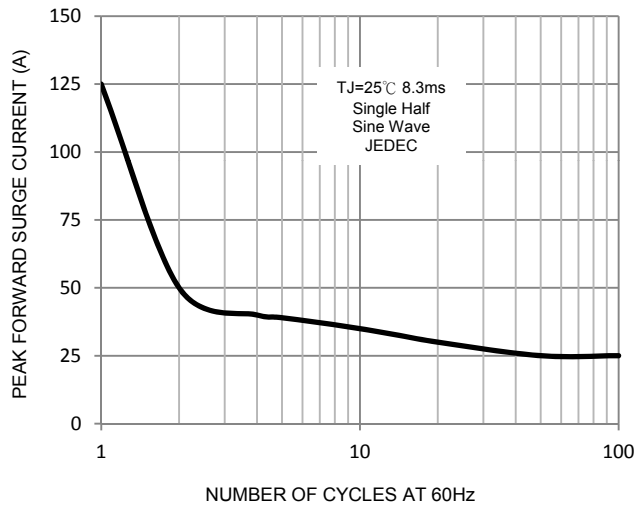

FIG. 4-TYPICAL REVERSE CHARACTERISTICS

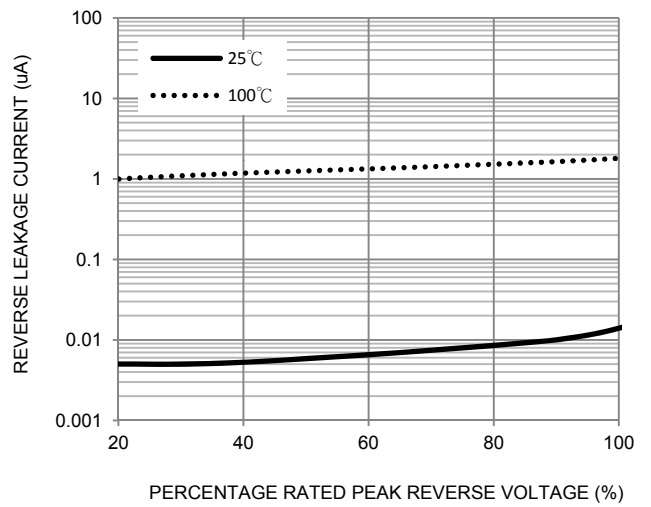

FIG. 5-TYPICAL JUNCTION CAPACITANCE

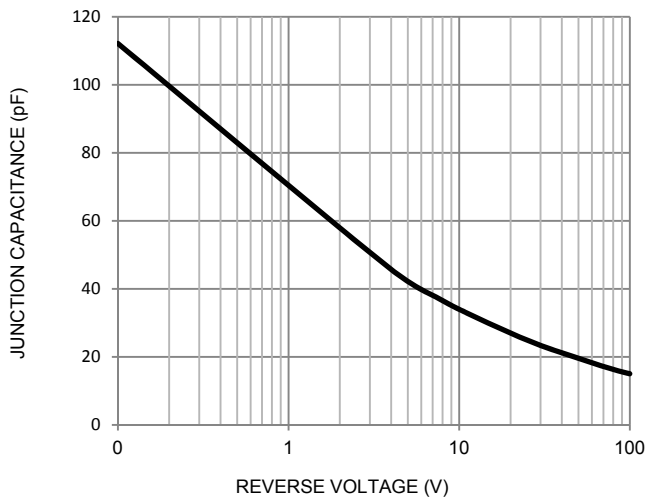

FIG. 6-Reverse Recovery Time Characteristic and Test Circuit

