

# HFBR-53A3VEMZ/HFBR-53A3VMZ

RoHS Compliant 3.3 V 1 x 9 Fiber Optic Transceivers  
for Fibre Channel

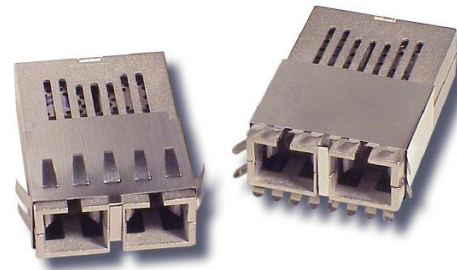

## Data Sheet



### Description

The HFBR-53A3VEMZ/VMZ transceivers from Avago Technologies allow the system designer to implement a range of solutions for multimode Fibre Channel applications.

The overall Avago transceiver product consists of three sections: the transmitter and receiver optical subassemblies, an electrical subassembly, and the package housing which incorporates a duplex SC connector receptacle.

### Transmitter Section

The transmitter section of the HFBR-53A3VEMZ/VMZ consists of an 850 nm Vertical Cavity Surface Emitting Laser (VCSEL) in an Optical Subassembly (OSA), which mates to the fiber cable. The OSA is driven by a custom, silicon bipolar IC which converts differential PECL compatible logic signals into an analog laser diode drive current. The high speed output lines are internally AC-coupled and differentially terminate with a 100  $\Omega$  resistor.

### Receiver Section

The receiver of the HFBR-53A3VEMZ/VMZ includes a GaAs PIN photo-diode mounted together with a custom, silicon bipolar transimpedance preamplifier IC in an OSA. This OSA is mated to a custom silicon bipolar circuit that provides post-amplification and quantization.

The post-amplifier also includes a Signal Detect circuit which provides a TTL logic-high output upon detection of a usable input optical signal level. The high speed output lines are internally AC-coupled.

### Features

- Fully RoHS compliant
- Compliant with ANSI X3.297-1996 Fibre Channel Physical Interface FC-PH-2 revision 7.4 proposed specification for 100-M5-SN-I and 100-M6-SN-I signal interfaces
- Performance  
HFBR-53A3VEMZ/VMZ:  
300 m links in 62.5/125  $\mu\text{m}$  MMF cables  
500 m links in 50/125  $\mu\text{m}$  MMF cables
- Wave solder and aqueous wash process compatible
- Industry standard mezzanine height  
1 x 9 package style with integral duplex SC connector
- IEC 60825-1 Class 1/CDRH Class I laser eye safe
- Single +3.3 V power supply operation with PECL compatible logic interfaces and TTL Signal Detect

### Applications

- Mass storage systems I/O
- Computer systems I/O
- High-speed peripheral interface
- High-speed switching systems
- Computer systems I/O
- Host adapter I/O
- RAID cabinets

### Related Products

- Versions of this transceiver module also available for +5 V operation (AFBR-53D3Z)

## Package and Handling Instructions

### Flammability

The HFBR-53A3VEMZ/VMZ transceiver housing is made of high strength, heat resistant, chemically resistant, and UL 94V-0 flame retardant plastic.

### Recommended Solder and Wash Process

The HFBR-53A3VEMZ/VMZ is compatible with industry-standard wave or hand solder processes.

### Process Plug

This transceiver is supplied with a process plug (HFBR-5000) for protection of the optical ports within the duplex SC connector receptacle. This process plug prevents contamination during wave solder and aqueous rinse as well as during handling, shipping, and storage. It is made of a high-temperature, molded sealing material that can withstand 80° C and a rinse pressure of 110lbs per square inch.

### Recommended Solder Fluxes

Solder fluxes used with the HFBR-53A3VEMZ/VMZ should be water-soluble, organic fluxes. Recommended solder fluxes include Lonco 3355-11 from London Chemical West, Inc. of Burbank, CA, and 100 Flux from Alpha-Metals of Jersey City, NJ.

### Recommended Cleaning/Degrading Chemicals

*Alcohols:* methyl, isopropyl, isobutyl.

*Aliphatics:* hexane, heptane.

*Other:* soap solution, naphtha.

*Do not use* partially halogenated hydrocarbons such as 1,1,1 trichloroethane, ketones such as MEK, acetone, chloroform, ethyl acetate, methylene dichloride, phenol, methylene chloride, or N-methylpyrrolidone. Also, Avago does not recommend the use of cleaners that use halogenated hydrocarbons because of their potential environmental harm.

### Regulatory Compliance

(See the Regulatory Compliance Table for transceiver performance)

The overall equipment design will determine the certification level. The transceiver performance is offered as a figure of merit to assist the designer in considering their use in equipment designs.

### Electrostatic Discharge (ESD)

There are two design cases in which immunity to ESD damage is important.

The first case is during handling of the transceiver prior to mounting it on the circuit board. It is important to use normal ESD handling precautions for ESD sensitive devices. These precautions include using grounded wrist straps, work benches, and floor mats in ESD controlled areas. The transceiver performance has been shown to provide adequate performance in typical industry production environments.

The second case to consider is static discharges to the exterior of the equipment chassis containing the transceiver parts. To the extent that the duplex SC connector receptacle is exposed to the outside of the equipment chassis it may be subject to whatever system-level ESD test criteria that the equipment is intended to meet. The transceiver performance is more robust than typical industry equipment requirements of today.

### Electromagnetic Interference (EMI)

Most equipment designs utilizing these high-speed transceivers from Avago will be required to meet the requirements of FCC in the United States, CENELEC EN55022 (CISPR 22) in Europe and VCCI in Japan. Refer to EMI section (page 4) for more details.

### Immunity

Equipment utilizing these transceivers will be subject to radio-frequency electromagnetic fields in some environments. These transceivers have good immunity to such fields due to their shielded design.

### Eye Safety

These laser-based transceivers are classified as AEL Class 1 (U.S. 21 CFR(J) and AEL Class 1 per EN 60825-1 (+A11)). They are eye safe when used within the data sheet limits per CDRH. They are also eye safe under normal operating conditions and under all reasonably foreseeable single fault conditions per EN60825-1. Avago has tested the transceiver design for compliance with the requirements listed below under normal operating conditions and under single fault conditions where applicable. TÜV Rheinland has granted certification to these transceivers for laser eye safety and use in EN 60950 and EN 60825-2 applications. Their performance enables the transceivers to be used without concern for eye safety up to maximum volts transmitter  $V_{CC}$ .

**CAUTION:**

There are no user serviceable parts nor any maintenance required for the HFBR-53A3VEMZ/VMZ. All adjustments are made at the factory before shipment to our customers. Tampering with or modifying the performance of the HFBR-53A3VEMZ/VMZ will result in voided product warranty. It may also result in improper operation of the HFBR-53A3VEMZ/VMZ circuitry, and possible overstress of the laser source. Device degradation or product failure may result.

Connection of the HFBR-53A3VEMZ/VMZ to a non-approved optical source, operating above the recommended absolute maximum conditions or operating the HFBR-53A3VEMZ/VMZ in a manner inconsistent with its design and function may result in hazardous radiation exposure and may be considered an act of modifying or manufacturing a laser product. The person(s) performing such an act is required by law to recertify and reidentify the laser product under the provisions of U.S. 21 CFR (Subchapter J).

**Regulatory Compliance**

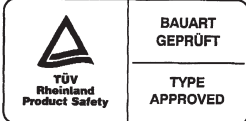
Feature	Test Method	Performance
Electrostatic Discharge (ESD) to the Electrical Pins	MIL-STD-883C Method 3015.4	Class 1 (> 1500 V).
Electrostatic Discharge (ESD) to the Duplex SC Receptacle	Variation of IEC 801-2	Typically withstand at least 15 kV without damage when the duplex SC connector receptacle is contacted by a Human Body Model probe.
Electromagnetic Interference (EMI)	FCC Class B CENELEC EN55022 Class B (CISPR 22A) VCCI Class 1	Margins are dependent on customer board and chassis designs.
Immunity	Variation of IEC 801-3	Typically show no measurable effect from a 10 V/m field swept from 27 to 1000 MHz applied to the transceiver without a chassis enclosure.
Laser Eye Safety and Equipment Type Testing	US 21 CFR, Subchapter J per Paragraphs 1002.10 and 1002.12	AEL Class I, FDA/CDRH HFBR-53A3V*MZ Accession #2071022
	EN 60825-1: 1994 + A11:1996 EN 60825-2: 1994 + A1 EN 60950: 1992 + A1 + A2 + A3 + A4 + A11	AEL Class 1, TÜV Rheinland of North America HFBR-53A3V*MZ: Certificate #R9771018.5 Protection Class III
Component Recognition	Underwriters Laboratories and Canadian Standards Association Joint Component Recognition for Information Technology Equipment Including Electrical Business Equipment.	UL File E173874

## APPLICATION SUPPORT

### Optical Power Budget and Link Penalties

The worst-case Optical Power Budget (OPB) in dB for a fiber-optic link is determined by the difference between the minimum transmitter output optical power (dBm avg) and the lowest receiver sensitivity (dBm avg). This OPB provides the necessary optical signal range to establish a working fiber-optic link. The OPB is allocated for the fiber-optic cable length and the corresponding link penalties. For proper link performance, all penalties that affect the link performance must be accounted for within the link optical power budget.

### Data Line Interconnections

Avago's HFBR-53A3VEMZ/VFMZ fiber-optic transceiver is designed for compatible PECL signals. The transmitter inputs are internally AC-coupled to the laser driver circuit from the transmitter input pins (pins 7, 8). The transmitter driver circuit for the laser light source is an AC-coupled circuit. This circuit regulates the output optical power. The regulated light output will maintain a constant output optical power provided the data pattern is reasonably balanced in duty factor. If the data duty factor has long, continuous state times (low or high data duty factor), then the output optical power will gradually change its average output optical power level to its pre-set value.

The receiver section is internally AC-coupled between the pre-amplifier and the post-amplifier stages. The actual Data and Data-bar outputs of the post-amplifier are AC-coupled to their respective output pins (pins 2, 3). Signal Detect is a single-ended, TTL output signal that is DC-coupled to pin 4 of the module. Signal Detect should not be AC-coupled externally to the follow-on circuits because of its infrequent state changes.

Caution should be taken to account for the proper interconnection between the supporting Physical Layer integrated circuits and this HFBR-53A3VEMZ/VFMZ transceiver. Figure 3 illustrates a recommended interface circuit for interconnecting to a DC PECL compatible fiber-optic transceiver.

### Eye Safety Circuit

For an optical transmitter device to be eye-safe in the event of a single fault failure, the transmitter must either maintain normal, eye-safe operation or be disabled.

In the HFBR-53A3VEMZ/VFMZ there are three key elements to the laser driver safety circuitry: a monitor diode, a window detector circuit, and direct control of the laser bias. The window detection circuit monitors the average optical power using the monitor diode. If a fault occurs such that the transmitter DC regulation circuit cannot maintain the preset bias conditions for the laser emitter within  $\pm 20\%$ , the transmitter will automatically be disabled. Once this has occurred, only an electrical power reset will allow an attempted turn-on of the transmitter.

### Signal Detect

The Signal Detect circuit provides a TTL low output signal when the optical link is broken or when the transmitter is off. The Signal Detect threshold is set to transition from a high to low state between the minimum receiver input optional power and -30 dBm avg. input optical power indicating a definite optical fault (e.g., unplugged connector for the receiver or transmitter, broken fiber, or failed far-end transmitter or data source). A Signal Detect indicating a working link is functional when receiving encoded 8B/10B characters. The Signal Detect does not detect receiver data error or error-rate. Data errors are determined by signal processing following the transceiver.

### Electromagnetic Interference (EMI)

One of a circuit board designer's foremost concerns is the control of electromagnetic emissions from electronic equipment. Success in controlling generated Electromagnetic Interference (EMI) enables the designer to pass a governmental agency's EMI regulatory standard; and more importantly, it reduces the possibility of interference to neighboring equipment. The EMI performance of an enclosure using these transceivers is dependent on the chassis design. Avago encourages using standard RF suppression practices and avoiding poorly EMI-sealed enclosures.

## Absolute Maximum Ratings

Stresses in excess of the absolute maximum ratings can cause catastrophic damage to the device. Limits apply to each parameter in isolation, all other parameters having values within the recommended operating conditions. It should not be assumed that limiting values of more than one parameter can be applied to the product at the same time. Exposure to the absolute maximum ratings for extended periods can adversely affect device reliability.

Parameter	Symbol	Min.	Typ.	Max.	Units	Reference
Storage Temperature	$T_S$	-40		+100	°C	
Supply Voltage	$V_{CC}$	-0.5		5.0	V	1
Transmitter Differential Input Voltage	$V_D$			2.2	V	
Relative Humidity	RH	5		95	%	
TTL Signal Detect Current – Low	$I_{OL, MAX}$	-5			mA	
TTL Signal Detect Current – High	$I_{OH, MAX}$			4.0	mA	

## Recommended Operating Conditions

Parameter	Symbol	Min.	Typ.	Max.	Units	Reference
Ambient Operating Temperature	$T_A$	0		+70	°C	
Case Temperature	$T_C$	0		+80	°C	2
Supply Voltage	$V_{CC}$	3.14		3.47	V	
Power Supply Rejection	PSR		100		mV <sub>p-p</sub>	3
Transmitter Differential Input Voltage	$V_D$	0.4		1.6	V	
Received Data Output Load	$R_{DL}$		50		Ω	
TTL Signal Detect Output Current – Low	$I_{OL}$			1.0	mA	
TTL Signal Detect Output Current – High	$I_{OH}$	-400			μA	

## Process Compatibility

Parameter	Symbol	Min.	Typ.	Max.	Units	Reference
Hand Lead Soldering Temperature/Time	$T_{SOLD}/T_{SOLD}$			+260/10	°C/s	
Wave Soldering and Aqueous Wash	$T_{SOLD}/T_{SOLD}$			+260/10	°C/s	4

Notes:

1. The transceiver is class 1 eye safe up to  $V_{CC} = 5.0$  V.
2. Case temperature measurement referenced to the metal housing.
3. Tested with a 100 mV<sub>p-p</sub> sinusoidal signal in the frequency range from 10 Hz to 2 MHz on the  $V_{CC}$  supply with the recommended power supply filter (with C8) in place. Typically less than a 1 dB change in sensitivity is experienced.
4. Aqueous wash pressure < 110 psi.

## HFBR-53A3VEMZ/VFMZ, 850 nm VCSEL

### Transmitter Electrical Characteristics ( $T_A = 0^\circ\text{C}$ to $+70^\circ\text{C}$ , $V_{CC} = 3.14\text{ V}$ to $3.47\text{ V}$ )

Parameter	Symbol	Min.	Typ.	Max.	Units	Reference
Supply Current	$I_{CCT}$		55	75	mA	
Power Dissipation	$P_{DIST}$		0.18	0.26	$\Omega$	
Laser Reset Voltage	$V_{CCT-reset}$		2.5	2.0	V	1

### Receiver Electrical Characteristics ( $T_A = 0^\circ\text{C}$ to $+70^\circ\text{C}$ , $V_{CC} = 3.14\text{ V}$ to $3.47\text{ V}$ )

Parameter	Symbol	Min.	Typ.	Max.	Units	Reference
Supply Current	$I_{CCR}$		80	135	mA	
Power Dissipation	$P_{DISR}$		0.26	0.47	$\Omega$	
Data Output Voltage – Peak to Peak Differential	$V_{OPP}$	0.4		1.20	V	2
Data Output Rise Time	$t_r$			0.40	ns	3
Data Output Fall Time	$t_f$			0.40	ns	3
Signal Detect Output Voltage – Low	$V_{OL}$			0.6	V	4
Signal Detect Output Voltage – High	$V_{OH}$	2.2			V	4
Signal Detect Assert Time	$t_{SDA}$			100	$\mu\text{s}$	
Signal Detect Deassert Time	$t_{SDD}$			350	$\mu\text{s}$	

#### Notes:

1. The Laser Reset Voltage is the voltage level below which the  $V_{CCT}$  voltage must be lowered to cause the laser driver circuit to reset from an electrical/optical shutdown condition to a proper electrical/optical operating condition. The maximum value corresponds to the worst-case highest  $V_{CC}$  voltage necessary to cause a reset condition to occur. The laser safety shutdown circuit will operate properly with transmitter  $V_{CC}$  levels of  $2.5\text{ Vdc} \leq V_{CC} \leq 5.0\text{ Vdc}$ .
2. These outputs are compatible with 10 K, 10 KH, and 100 K ECL and PECL inputs.
3. These are 20-80% values.
4. Under recommended operating conditions.

## HFBR-53A3VEMZ/VFMZ, 850 nm VCSEL

### Transceiver Optical Characteristics ( $T_A = 0^\circ\text{C}$ to $+70^\circ\text{C}$ , $V_{CC} = 3.14\text{ V}$ to $3.47\text{ V}$ )

Parameter	Symbol	Min.	Typ.	Max.	Unit	Reference
Output Optical Power 50/125 $\mu\text{m}$ , NA = 0.20 fiber	$P_{OUT}$	-10		-4	dBm avg.	
Output Optical Power 62.5/125 $\mu\text{m}$ , NA = 0.275 fiber	$P_{OUT}$	-10		-4	dBm avg.	
Optical Extinction Ratio		9			dB	1
Center Wavelength	$\lambda_C$	830	850	860	nm	
Spectral Width – rms	$\sigma$			0.85	nm rms	
Optical Rise/Fall Time	$t_r / t_f$			0.45	ns	2, 3, Figure 1
$RIN_{12}$				-116	dB/Hz	
Deterministic Transmitter Jitter				188	ps	

### Receiver Optical Characteristics ( $T_A = 0^\circ\text{C}$ to $+70^\circ\text{C}$ , $V_{CC} = 3.14\text{ V}$ to $3.47\text{ V}$ )

Parameter	Symbol	Min.	Typ.	Max.	Unit	Reference
Input Optical Power	$P_{IN}$	-16		0	dBm avg.	4
Operating Center Wavelength	$\lambda_C$	770		860	nm	
Return Loss		12			dB	5
Signal Detect – Asserted	$P_A$			-17	dBm avg.	
Signal Detect – Deasserted	$P_D$	-30			dBm avg.	
Signal Detect – Hysteresis	$P_A - P_D$	1.5			dB	

#### Notes:

- Optical Extinction Ratio is defined as the ratio of the average optical power of the transmitter in the high ("1") state to the low ("0") state. This Optical Extinction Ratio is expressed in decibels (dB) by the relationship  $10\log(P_{high\ avg}/P_{low\ avg})$ .
- These are 20-80% values and include the effect of a fourth order filter.
- Laser transmitter pulse response characteristics are specified by an eye diagram (Figure 1). The characteristics include rise time, fall time, pulse overshoot, pulse undershoot, and ringing, all of which are controlled to prevent excessive degradation of the receiver sensitivity.
- The receive sensitivity is measured using a worst case extinction ratio penalty while sampling at the center of the eye.
- Return loss is defined as the minimum attenuation (dB) of received optical power for energy reflected back into the optical fiber.

**Table 1. Pinout Table**

Pin	Symbol	Functional Description
Mounting Pins		The mounting pins are provided for transceiver mechanical attachment to the circuit board. They are embedded in the nonconductive plastic housing and are not connected to the transceiver internal circuit, nor is there a guaranteed connection to the metallized housing in the EM and FM versions. They should be soldered into plated-through holes on the printed circuit board.
1	$V_{EER}$	Receiver Signal Ground Directly connect this pin to receiver signal ground plane. (For HFBR-53A5VM, $V_{EER} = V_{EET}$ )
2	RD+	Receiver Data Out AC coupled – PECL compatible.
3	RD-	Receiver Data Out Bar AC coupled – PECL compatible.
4	SD	Signal Detect Signal Detect is a single-ended TTL output. If Signal Detect output is not used, leave it open-circuited. Normal optical input levels to the receiver result in a logic “1” output, $V_{OH}$ , asserted. Low input optical levels to the receiver result in a fault condition indicated by a logic “0” output $V_{OL}$ , deasserted.
5	$V_{CCR}$	Receiver Power Supply Provide +3.3 Vdc via the recommended receiver power supply filter circuit. Locate the power supply filter circuit as close as possible to the $V_{CCR}$ pin.
6	$V_{CCT}$	Transmitter Power Supply Provide +3.3 Vdc via the recommended transmitter power supply filter circuit. Locate the power supply filter circuit as close as possible to the $V_{CCT}$ pin.
7	TD-	Transmitter Data In-Bar AC coupled – PECL compatible. Internally terminated differentially with 100 $\Omega$ .
8	TD+	Transmitter Data In AC coupled – PECL compatible. Internally terminated differentially with 100 $\Omega$ .
9	$V_{EET}$	Transmitter Signal Ground Directly connect this pin to the transmitter signal ground plane.

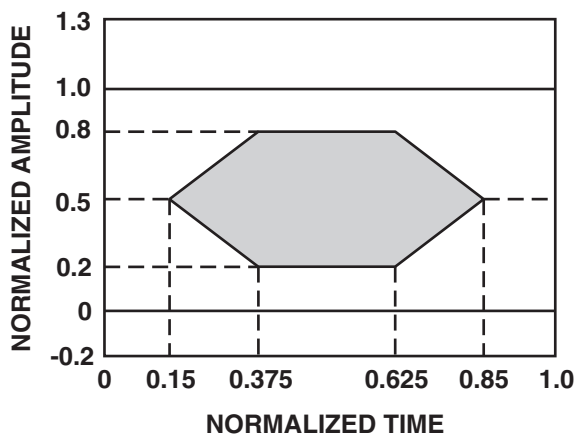

**Figure 1. Transmitter optical eye diagram mask.**

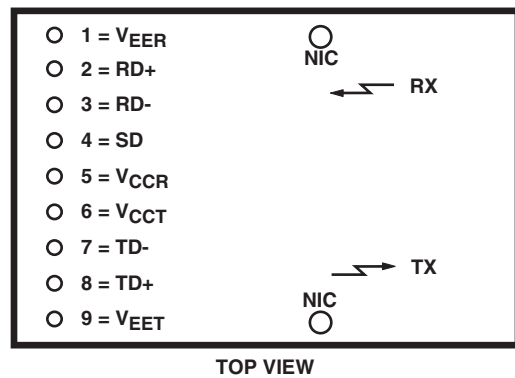

**Figure 2. Pin-out.**



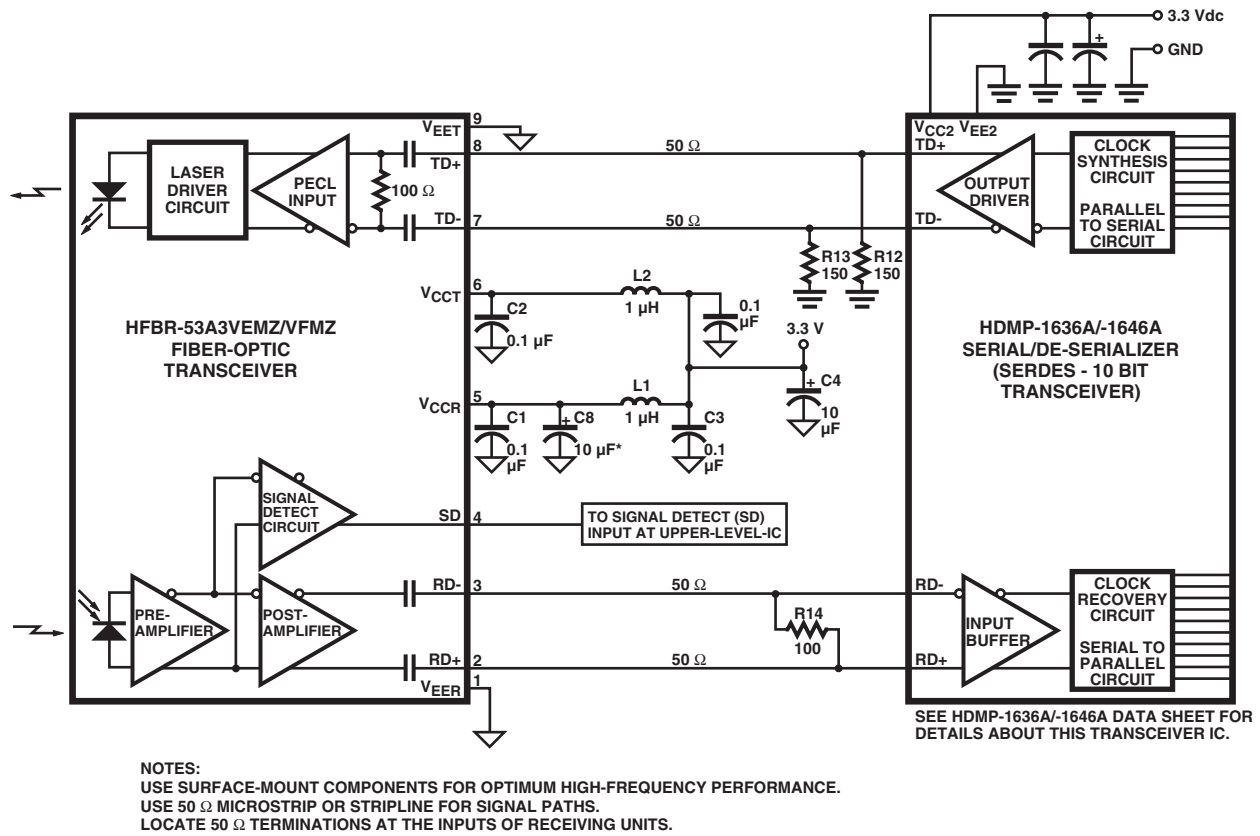

Figure 3. Recommended HFBR-53A3VEMZ/VMZ fiber-optic transceiver and HDMP-1636A/1646A SERDES integrated circuit transceiver interface and power supply filter circuits.

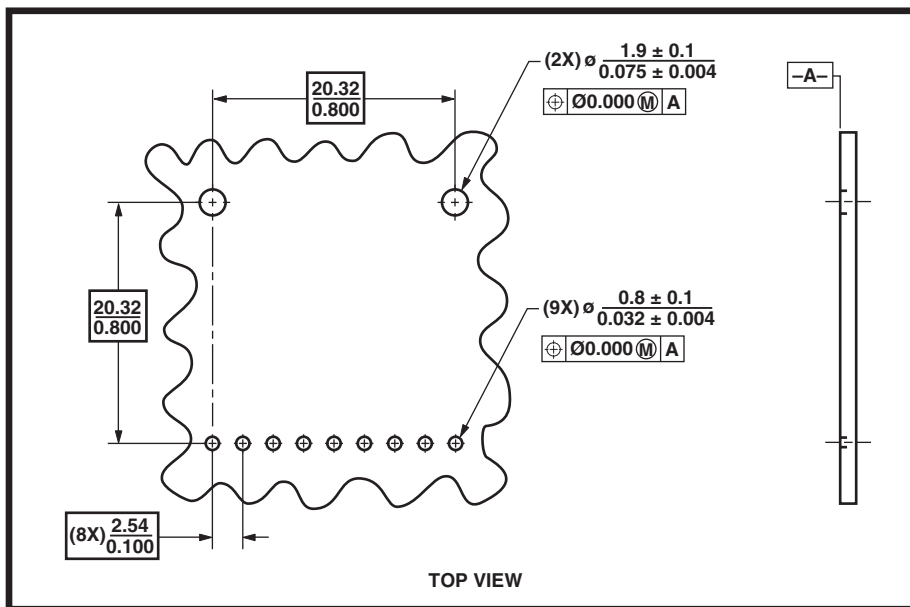
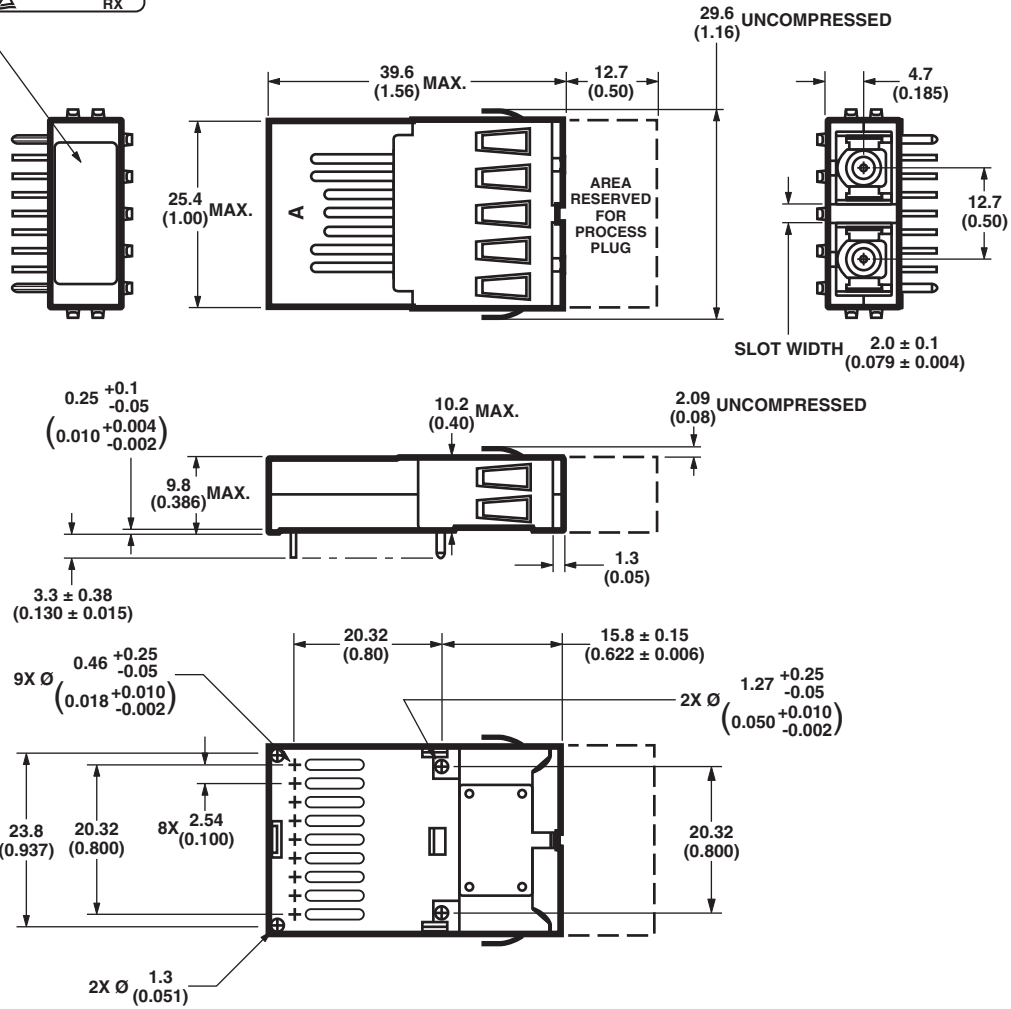

Figure 4. Recommended board layout hole pattern.

A  
 XXXX-XXXX  
 ZZZZ LASER PROD  
 21CFR(J) CLASS 1  
 COUNTRY OF ORIGIN YYWW  
 TX  RX

KEY:  
 YYWW = DATE CODE  
 FOR MULTIMODE MODULE:  
 XXXX-XXXX = HFBR-53xx  
 ZZZZ = 850 nm



DIMENSIONS ARE IN MILLIMETERS (INCHES).  
 ALL DIMENSIONS ARE ± 0.025 mm UNLESS OTHERWISE SPECIFIED.

Figure 5. Package outline for HFBR-53A3VEMZ.

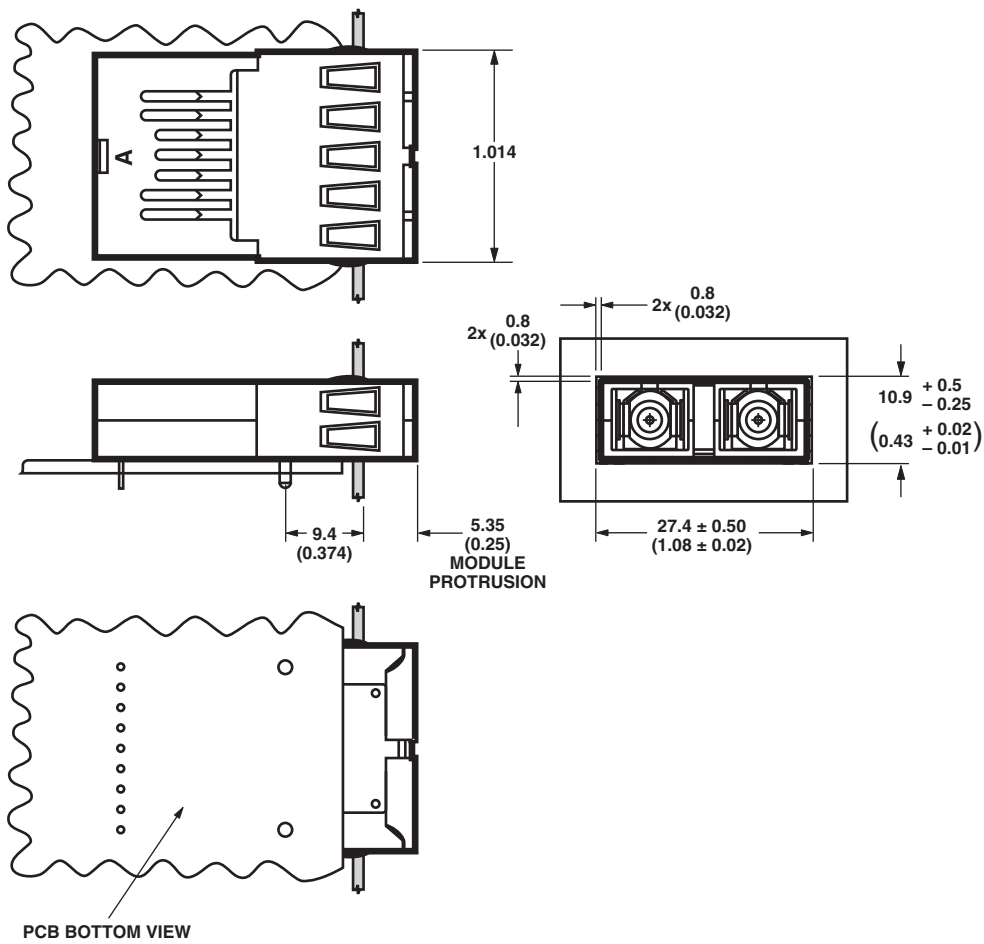

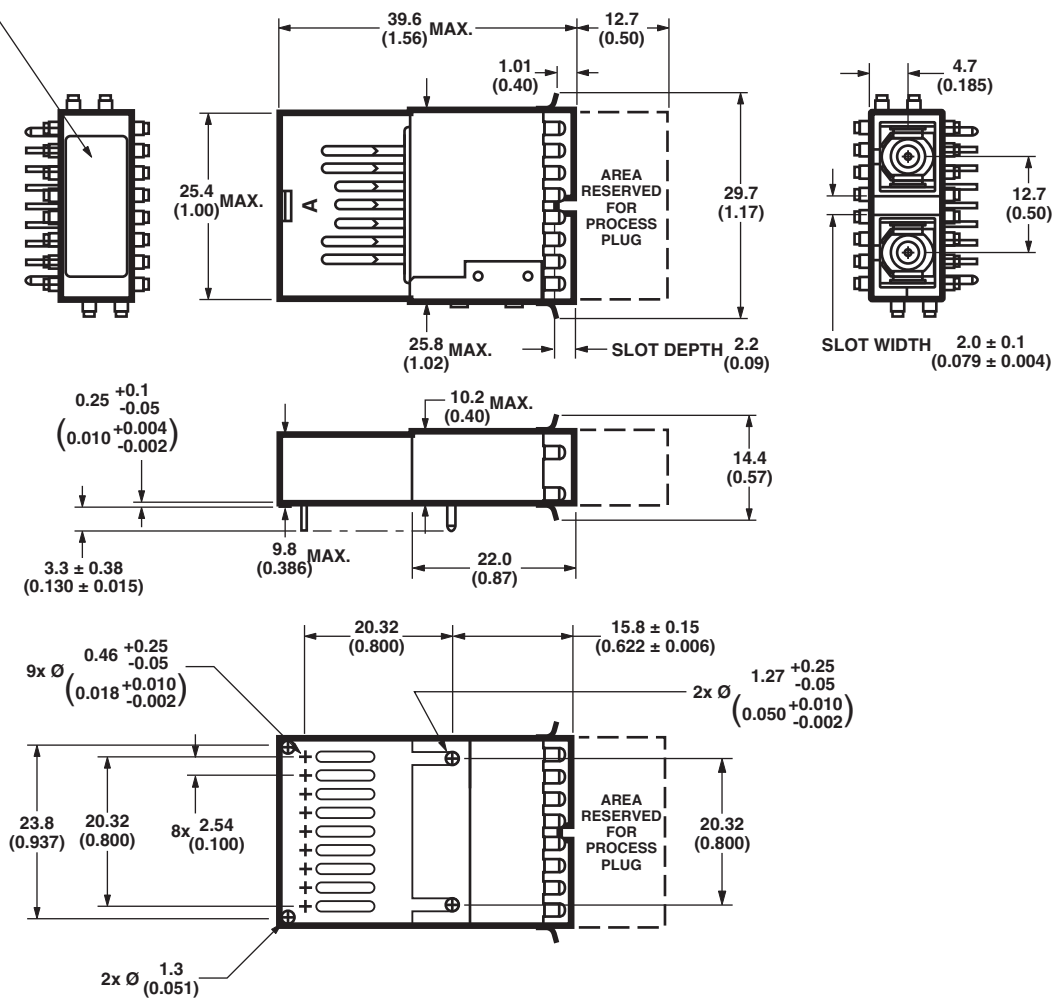

Figure 6. Suggested module positioning and panel cut-out for HFBR-53A3VEMZ.

**A** XXXX-XXXX  
 ZZZZ LASER PROD  
 21CFR(J) CLASS 1  
 COUNTRY OF ORIGIN YYWW  
 TX  RX

KEY:  
 YYWW = DATE CODE  
 FOR MULTIMODE MODULE:  
 XXXX-XXXX = HFBR-53xx  
 ZZZZ = 850 nm



DIMENSIONS ARE IN MILLIMETERS (INCHES).  
 ALL DIMENSIONS ARE ± 0.025 mm UNLESS OTHERWISE SPECIFIED.

Figure 7. Package outline for HFBR-53A3VFMZ.

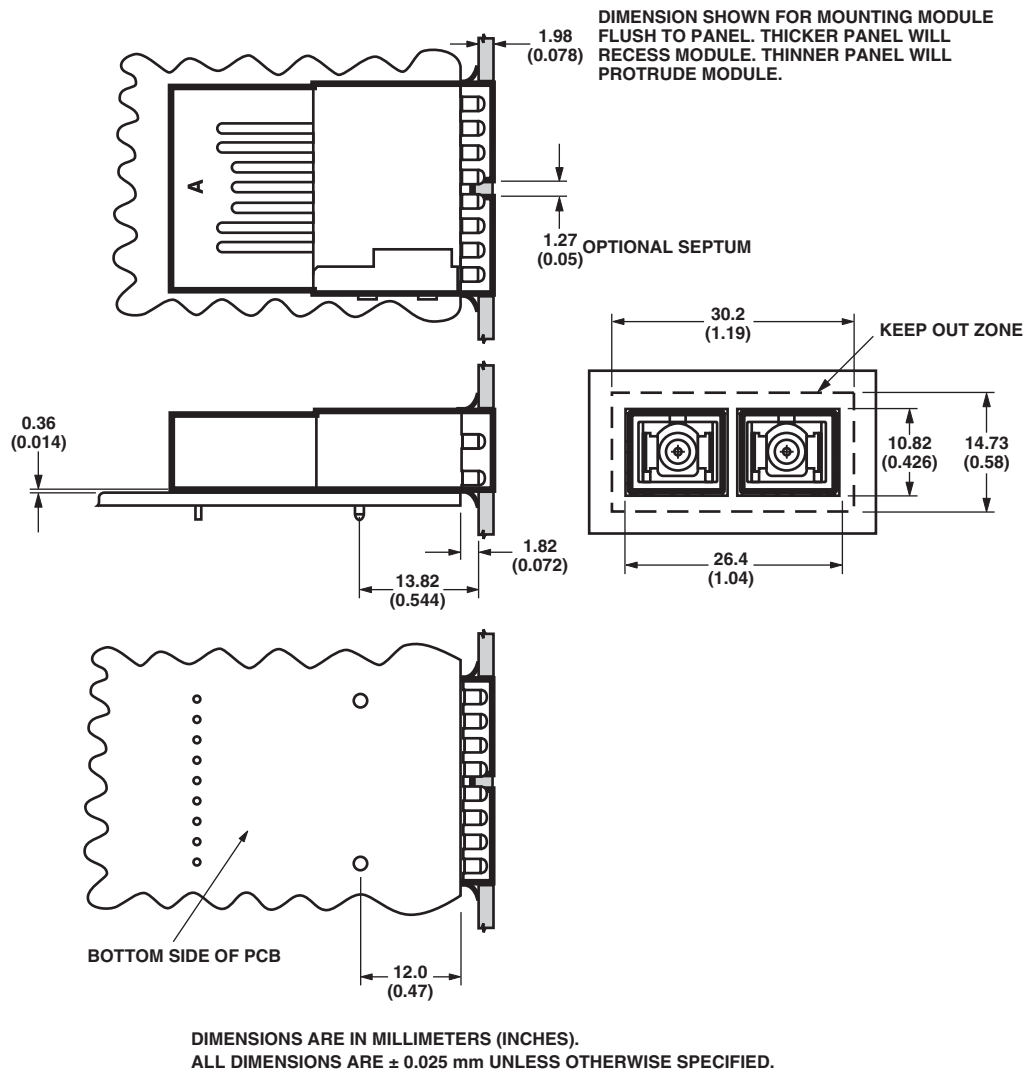

Figure 8. Suggested module positioning and panel cut-out for HFBR-53A3VMZ.

### Ordering Information

850 nm VCSEL	(SX – Short Wavelength Laser)
HFBR-53A3VEMZ	Extended shield, metal housing.
HFBR-53A3VMZ	Flush shield, metal housing.

For product information and a complete list of distributors, please go to our web site: [www.avagotech.com](http://www.avagotech.com)

Avago, Avago Technologies, and the A logo are trademarks of Avago Technologies in the United States and other countries. Data subject to change. Copyright © 2005–2014 Avago Technologies. All rights reserved. Obsoletes 5989-4731EN AV02-4620EN - August 27, 2014

**AVAGO**  
TECHNOLOGIES