

FEATURES

- Micro size plug-in design
- 20A continuous current capacity
- Plastic cover for rough environment protection

TYPICAL AUTOMOTIVE APPLICATIONS

- Blower motor control
- Ventilation motor
- Compressor control system
- Radiator cooling fan
- Stationary heating
- Head lights, full beam/dimmed
- Fog lights

CONTACT DATA

Form		1 Form A (H)	1 Form B (D)	1 Form C (Z)	
				NO	NC
Max. Switching Current	Make	90A (S: 120A)	20	90A (S: 120A)	20A
	Break	30A	15	30A	15A
Material		AgNi0.15, AgSn0InO			
Initial Contact Resistance		100 mΩ max. at 0.1A, 6VDC			
Max. Switching Voltage		See curve, current dependent			
Max. Continuous Current		20A	15A	20A	10A
Min. Load		0.1A, 12VDC			
Service Life	Mechanical	10 ⁷ ops.			
	Electrical	2 x 10 ⁵ ops, see Note 4			

COIL DATA

Coil Voltage Code	Nominal Voltage (VDC)	Resistance (Ω) ±10%		Nominal Operate Voltage max. (VDC)	Allowable Voltage (VDC)		Nominal Release Voltage min. (VDC)
		A, B	C		A, B, C	A, B	
006	6	32	25	3.6	10.4	9.2	0.6
012	12	123	97	7.2	20.4	18.1	1.2
024	24	483	384	14.3	40.4	36.0	2.4

CHARACTERISTICS

Operate Time	9 ms. typical
Release Time	7 ms. typical
Insulation Resistance	100 MΩ, at 500 VDC, 50%RH
Dielectric Strength	500 Vrms, 1 min.
Shock Resistance	20 g, 11ms.
Vibration Resistance	10-40 Hz: DA 1.27 mm; 40-70 Hz: 5 g; 70-100 Hz: DA 0.5 mm; 100-500 Hz: 10 g.
Drop Resistance	1 M height drop on concrete
Power Consumption	1.6W, unsuppressed; 1.81W, with resistor
Ambient Temperature	-40°C to 125°C operating; -40°C to 155°C storage
Weight	Plug-In: 14 g; PCB: 12 g, approx.

ORDERING DESIGNATION

Example:	HG4182 /	012	R -	H	A	4
Model						
Coil Voltage Code						
Paralleled Component						
Nil: Nil; R: Resistor;						
D: Diode (+) 85-86 (-);						
DR: Diode Reversed (-) 85-86 (+)						
Contact Form						
H: 1 Form A; D: 1 Form B; Z: 1 Form C						
Contact Material						
Nil: AgNi10; A: AgNi0.15; C: AgCdO; S: AgSn0InO						
Mounting Version						
Nil: Plug-In; 4: PCB						

REFERENCE CURVE

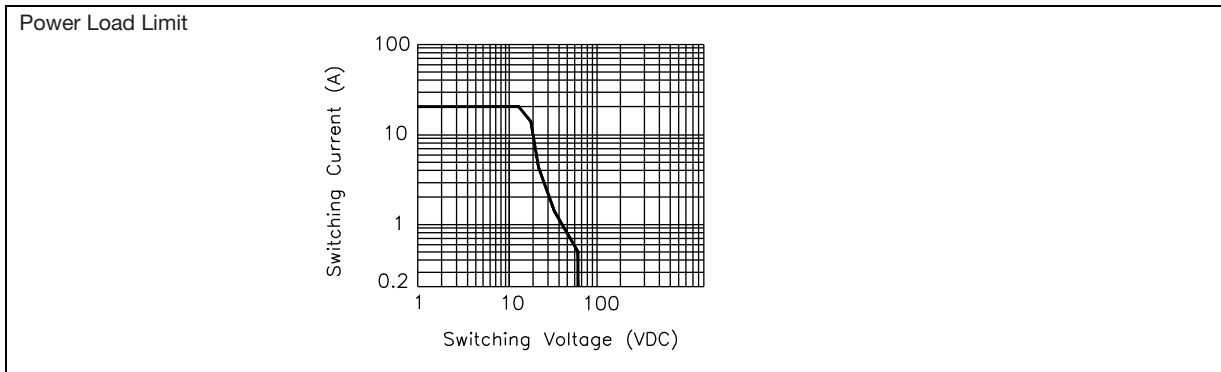

OVERALL DIMENSIONS, TERMINAL LAYOUTS, MOUNTING HOLES AND WIRING DIAGRAMS (mm)

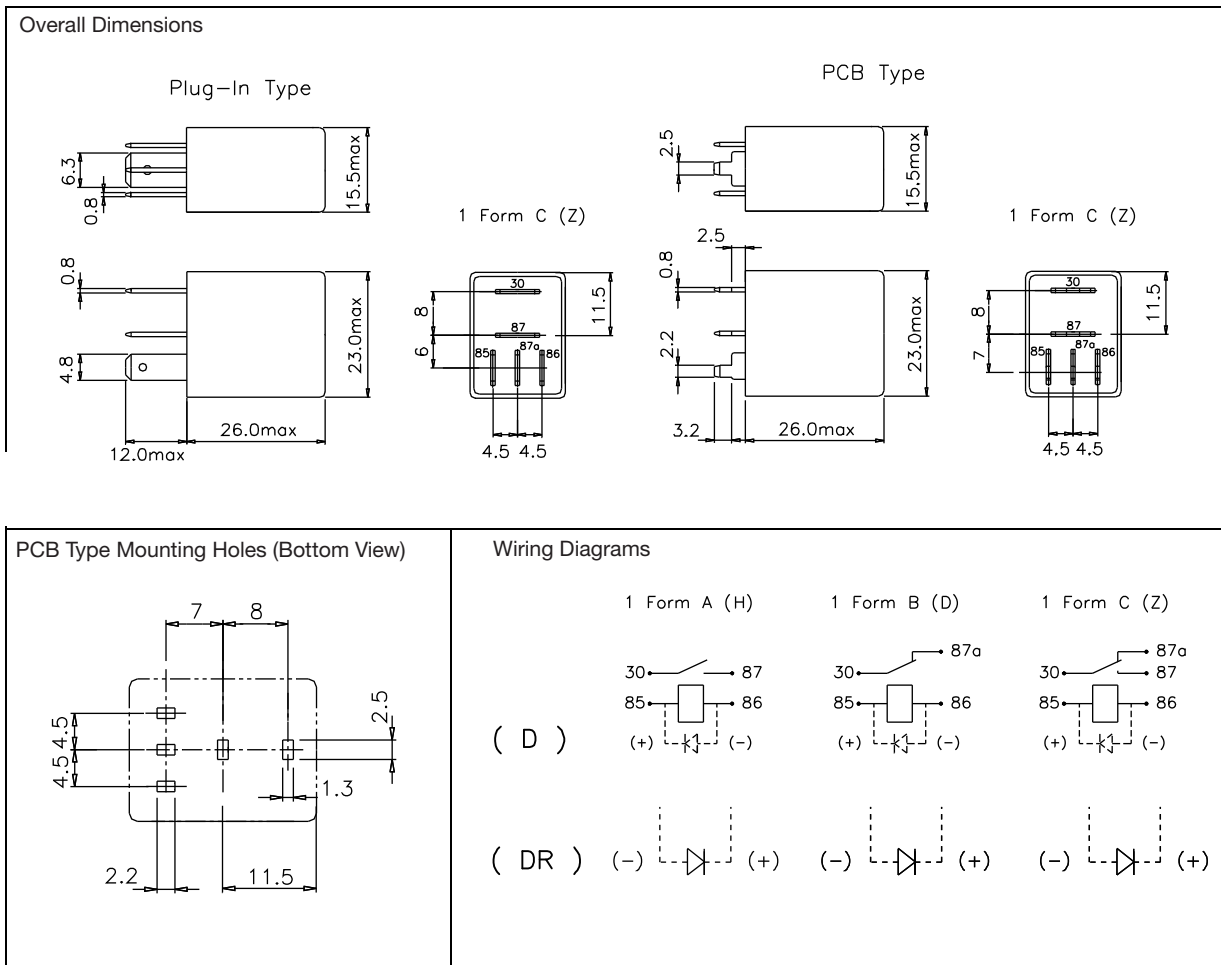

NOTES

1. All parameters, unless otherwise specified, are measured at ambient temperature 23°C.
2. Maximum make current refers to inrush current of lamp load.
3. At ambient temperature of 85°C, maximum allowable voltage should be reduced to 72%.
4. Electrical life obtained at resistive or inductive load at 20A, 15VDC with suitable arc-suppression circuit attached with operating frequency of 1 ops/sec.
5. Custom-made services available with operational quantity. Please let us know your special requirements.
6. Specifications subject to change without prior notice.

Willow Technologies Limited
 Shawlands Court
 Newchapel Road
 Lingfield
 Surrey RH7 6BL
 England
 Tel: +44 (0) 1342-835234
 Fax: +44 (0) 1342-834306
 email: sales@willow.co.uk