

PRELIMINARY

June 1998

12-Bit, 65 MSPS A/D Converter

Features

- Sampling Rate 65 MSPS
- Low Power at 65 MSPS 450mW
- Internal Sample and Hold
- Fully Differential Architecture
- Full Power Input Bandwidth 250MHz
- Low Data Latency
- TTL Compatible Clock Input
- CMOS Compatible Digital Data Outputs

Applications

- Multichannel Digital Communication Receivers
- Cellular/PCS Basestation Receivers
- Undersampling Digital IF
- Digital Subscriber Line (VDSL)
- Medical Ultrasound
- Reference Literature
 - AN9214, Using Harris High Speed A/D Converters

Description

The HI5865 is a monolithic, 12-bit, 65 MSPS Analog-to-Digital Converter fabricated in an advanced CMOS process. It is designed for high speed, high resolution applications where wide bandwidth, low power consumption and excellent SINAD performance are essential. With a 250MHz full power input bandwidth and high frequency accuracy, the converter is ideal for many types of communication systems employing digital IF architectures.

The HI5865 is designed with a fully differential pipelined architecture using a front end differential-in-differential-out Sample-and-Hold amplifier (S/H). The HI5865 has excellent dynamic performance while consuming 450mW of power at 65 MSPS.

Data output latches are provided which present valid data to the output bus with a low data latency of 9 clock cycles.

Ordering Information

PART NUMBER	TEMP. RANGE (°C)	PACKAGE	PKG. NO.
HI5865IN	-40 to 85	44 Ld MQFP	Q44.10x10
HI5865EVAL1	25	Evaluation Platform	

Pinout

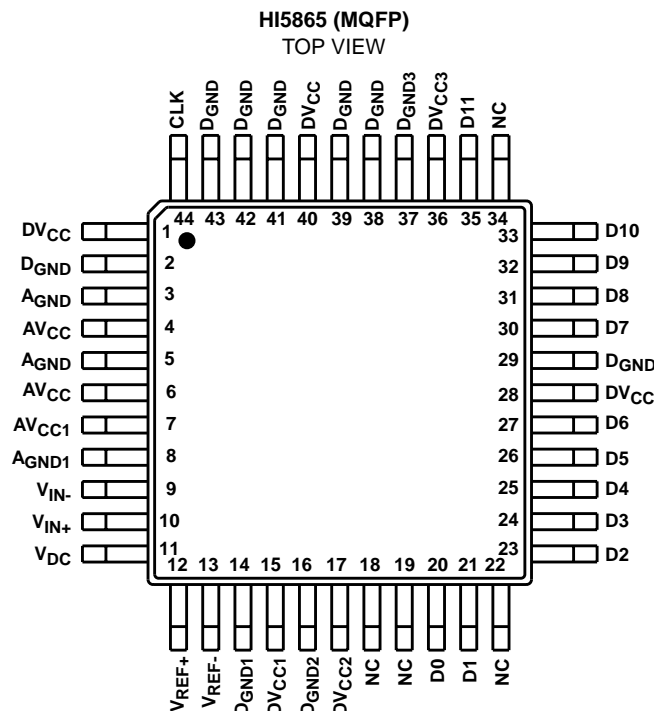

Metric Plastic Quad Flatpack Packages (MQFP/PQFP)

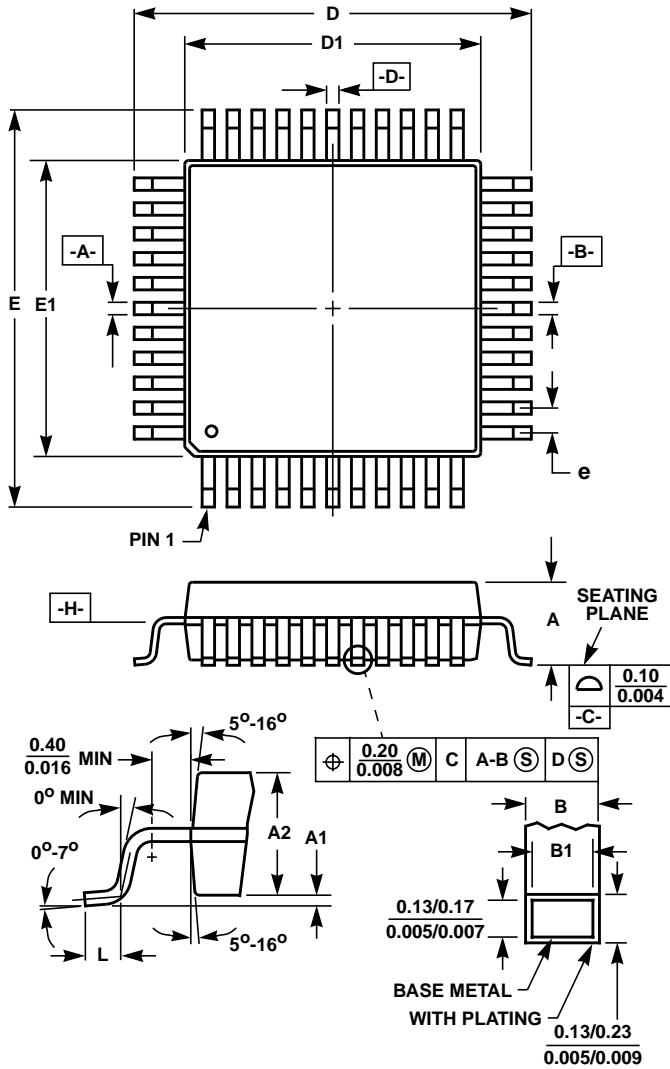

**Q44.10x10 (JEDEC MO-108AA-2 ISSUE A)
44 LEAD METRIC PLASTIC QUAD FLATPACK PACKAGE**

SYM-BOL	INCHES		MILLIMETERS		NOTES
	MIN	MAX	MIN	MAX	
A	-	0.093	-	2.35	-
A1	0.004	0.010	0.10	0.25	-
A2	0.077	0.083	1.95	2.10	-
B	0.012	0.018	0.30	0.45	6
B1	0.012	0.016	0.30	0.40	-
D	0.510	0.530	12.95	13.45	3
D1	0.390	0.398	9.90	10.10	4, 5
E	0.510	0.530	12.95	13.45	3
E1	0.390	0.398	9.90	10.10	4, 5
L	0.026	0.037	0.65	0.95	-
N	44		44		7
e	0.032 BSC		0.80 BSC		-

Rev. 1 1/94

NOTES:

1. Controlling dimension: MILLIMETER. Converted inch dimensions are not necessarily exact.
2. All dimensions and tolerances per ANSI Y14.5M-1982.
3. Dimensions D and E to be determined at seating plane **-C-**.
4. Dimensions D1 and E1 to be determined at datum plane **-H-**.
5. Dimensions D1 and E1 do not include mold protrusion. Allowable protrusion is 0.25mm (0.010 inch) per side.
6. Dimension B does not include dambar protrusion. Allowable dambar protrusion shall be 0.08mm (0.003 inch) total.
7. "N" is the number of terminal positions.