

1MHz, 18V, 2A Synchronous Step-Down Converter

DESCRIPTION

The HM1470H is a fully integrated, high-efficiency 2A synchronous rectified step-down converter. The HM1470H operates at high efficiency over a wide output current load range.

This device offers two operation modes, PWM control and PFM Mode switching control, which allows a high efficiency over the wider range of the load.

The HM1470H requires a minimum number of readily available standard external components and is available in a 6-pin SOT23 ROHS compliant package.

FEATURES

- High Efficiency: Up to 96%
- 1MHz Frequency Operation
- 2A Output Current
- No Schottky Diode Required
- 4.2V to 18V Input Voltage Range
- 0.8V Reference
- Slope Compensated Current Mode Control for Excellent Line and Load Transient Response
- Integrated internal compensation
- Stable with Low ESR Ceramic Output Capacitors
- Over Current Protection with Hiccup-Mode
- Thermal Shutdown
- Inrush Current Limit and Soft Start
- Available in SOT23-6
- -40°C to +85°C Temperature Range

APPLICATIONS

- Distributed Power Systems
- Digital Set Top Boxes
- Flat Panel Television and Monitors
- Wireless and DSL Modems
- Notebook Computer

TYPICAL APPLICATION

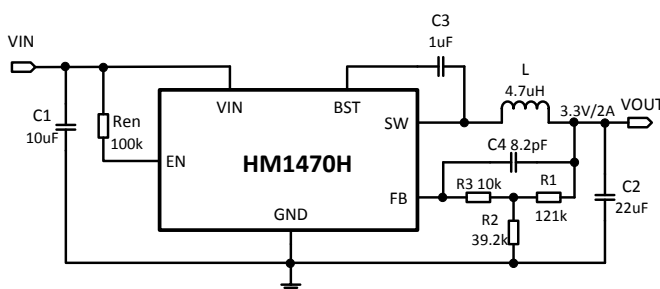

Figure 1.

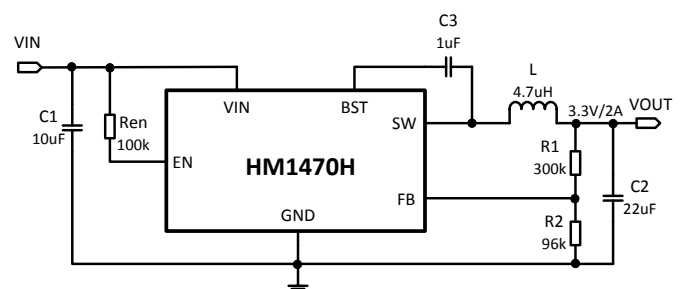

Figure 2.

Note: 1) C1 and C2 recommended using 10uF, 22uF ceramic capacitors. If the electrolytic capacitor is used, it is recommended that the ceramic capacitor in parallel with a capacitance value of 0.1uF or more.

2) The resistance R3 in Figure 1 makes the loop more stable. If it isn't used, the resistance R1, R2 should be adjusted (See Figure 2.). The value of R1 is recommended to be about 300kΩ.

3) C3 can be valued as 1uF, 0.1uF.

ORDERING INFORMATION

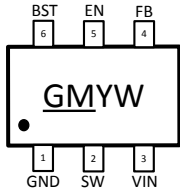
Mark Explanation <i>GM: Product Code</i> <i>YW: Date code (Year & Week)</i>		Ordering Information	
		Product ID	HM1470H
		Package	SOT23-6
		Devices per reel	3000

ABSOLUTE MAXIMUM RATING

Parameter	Value
Supply Voltage V_{IN}	-0.3V to 19V
Switch Node Voltage V_{SW}	-0.3V to ($V_{IN}+0.5V$)
Boost Voltage V_{BST}	$V_{SW}-0.3V$ to $V_{SW}+5V$
Enable Voltage V_{EN}	-0.3V to 19V
All Other Pins	-0.3V to 6V
Operating Temperature Range	-40°C to 85°C
Storage Temperature Range	-65°C to 150°C
Lead Temperature (Soldering, 10s)	300°C

ELECTRICAL CHARACTERISTICS

($V_{IN}=12V$, $V_{OUT}=5V$, $T_A=25^\circ C$, unless otherwise stated)

Parameter	Conditions	Min	Typ	Max	Unit
Input Voltage Range		4.2		18	V
UVLO Threshold			4.1		V
Supply Current in Operation	$V_{EN} = 2.0V$, $V_{FB} = 1.1V$		0.5		mA
Supply Current in Shutdown	$V_{EN} = 0V$ or $V_{EN} = GND$		5	10	µA
Regulated Feedback Voltage	$4.2V \leq V_{IN} \leq 18V$	0.784	0.8	0.816	V
High-side Switch On Resistance	$V_{BST-SW} = 5V$		150		mΩ
Low-side Switch On Resistance	$V_{IN} = 5V$		70		mΩ
High-side Switch Leakage Current	$V_{EN} = 0V$, $V_{SW} = 0V$		0	10	µA
Upper Switch Current Limit	Minimum Duty Cycle		3.8		A
Oscillation Frequency			1		MHz
Maximum Duty Cycle	$V_{FB} = 0.7V$		92		%
Minimum On Time			100		ns
EN Input Voltage "H"		1.5			V
EN Input Voltage "L"				0.6	V
Thermal Shutdown			160		°C

PIN DESCRIPTION

PIN #	NAME	DESCRIPTION
1	GND	Ground
2	SW	Switching Pin
3	VIN	Power supply Pin
4	FB	Adjustable version feedback input. Connect FB to the center point of the external resistor divider.
5	EN	Drive this pin to a logic-high to enable the IC. Drive to a logic-low to disable the IC and enter micro-power shutdown mode.
6	BST	Bootstrap. A capacitor connected between SW and BST pins is required to form a floating supply across the high-side switch driver.

ELECTRICAL PERFORMANCE

Tested under, $T_A=25^\circ\text{C}$, unless otherwise specified

Efficiency vs. Iout
 (Vout=1.2V)

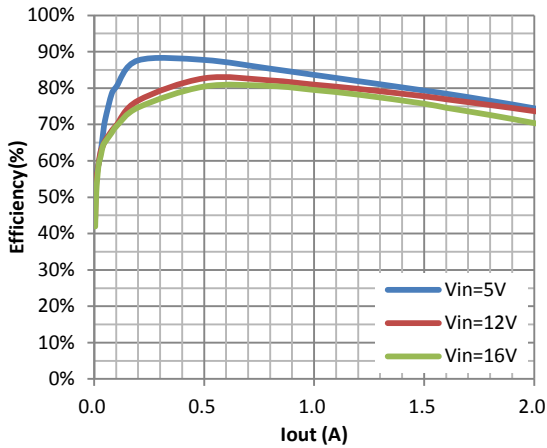

Efficiency vs. Iout
 (Vout=3.3V)

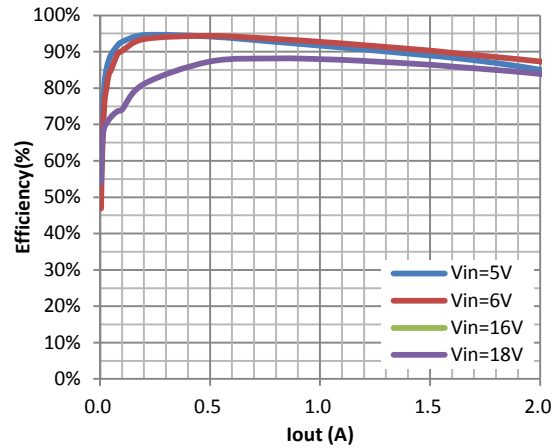

Efficiency vs. Iout
 (Vout=5.0V)

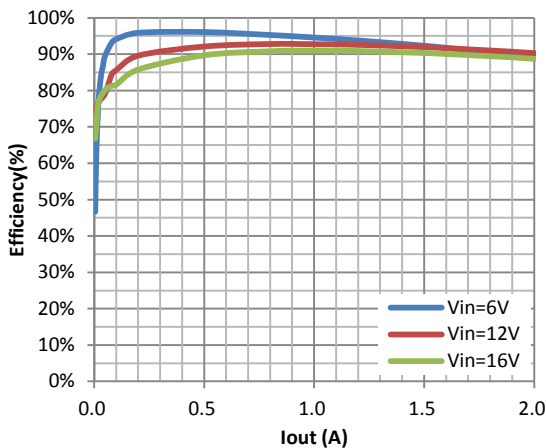

Vout vs. Iout
 (Vout=1.2V)

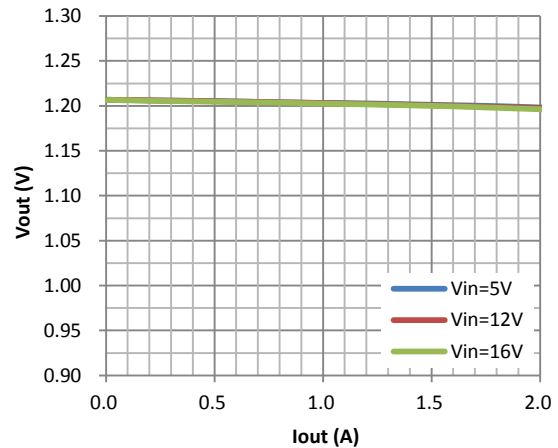

Vout vs. Iout
 (Vout=3.3V)

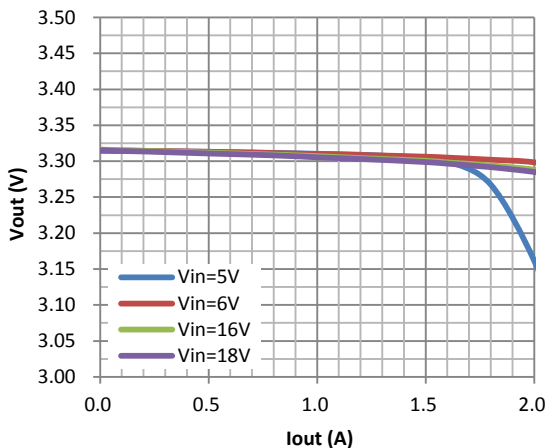

Vout vs. Iout
 (Vout=5.0V)

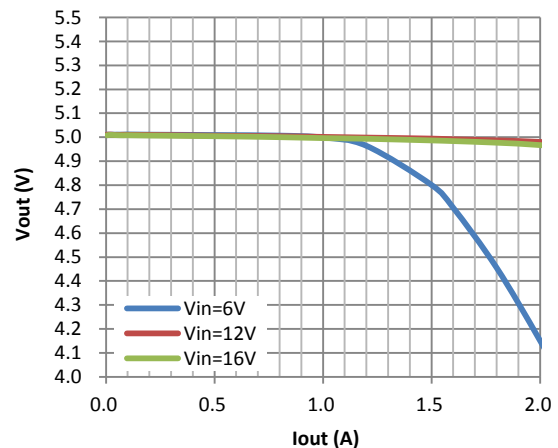

Efficiency vs. Vin
 Iout=1A

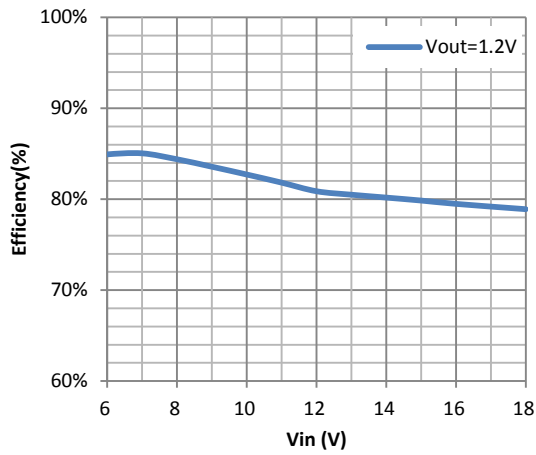

Vout vs. Vin
 Iout=1A

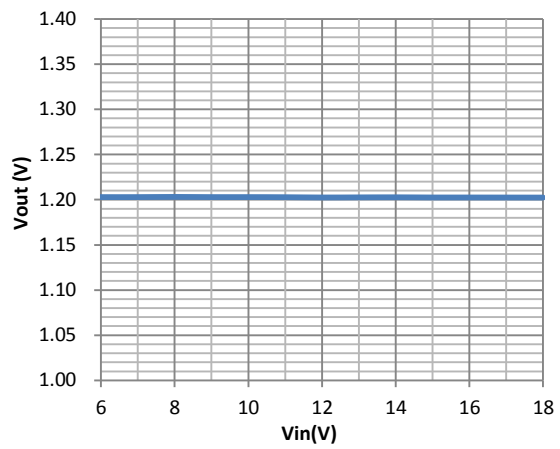

Load Transient

Vin=12V, Vout=3.3V, Iout=0.01~2A
 Ch2—Vout, Ch4—IL

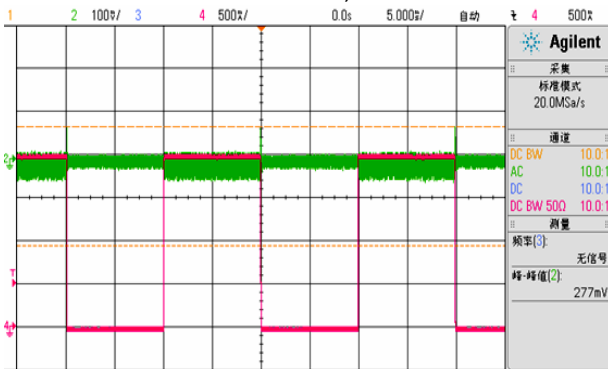

Load Transient

Vin=12V, Vout=3.3V, Iout=0.5~1A
 Ch2—Vout, Ch4—IL

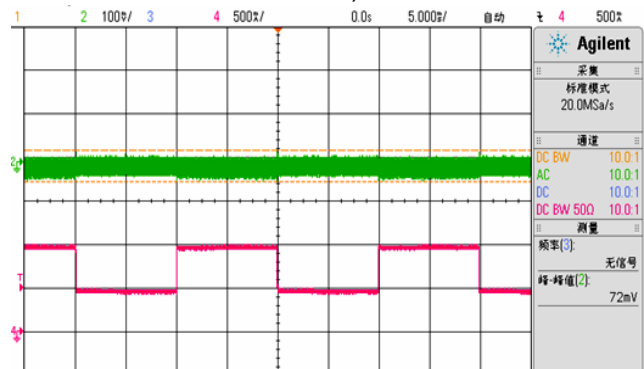

BLOCK DIAGRAM

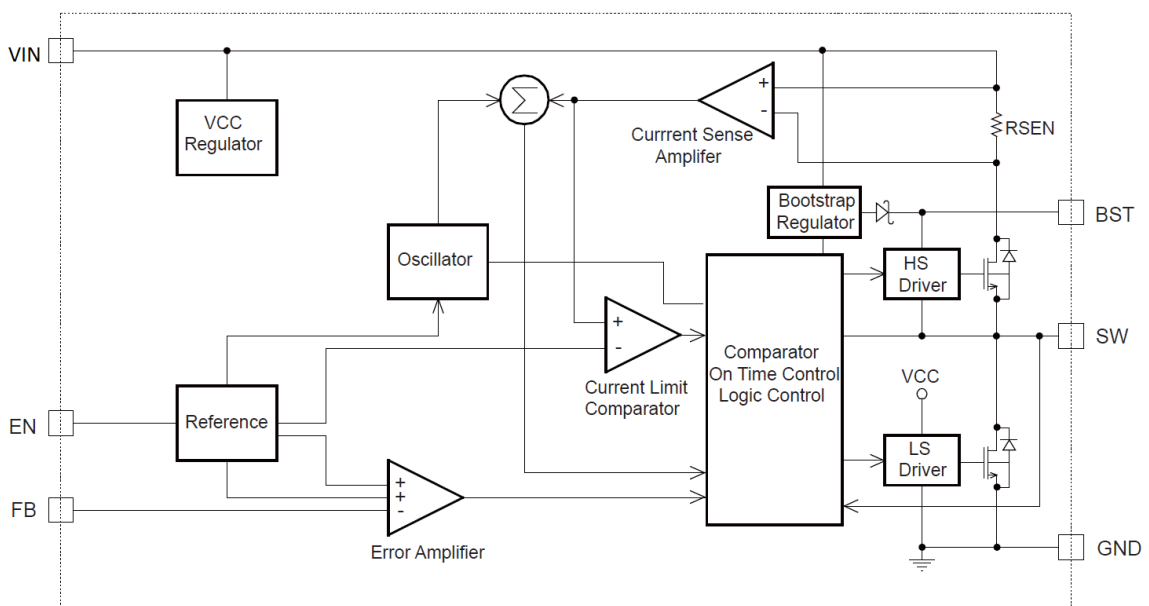

DETAILED DESCRIPTION

Internal Regulator

The HM1470H is a current mode step down DC/DC converter that provides excellent transient response with no extra external compensation components. This device contains an internal, low resistance, high voltage power MOSFET, and operates at a high 1M operating frequency to ensure a compact, high efficiency design with excellent AC and DC performance.

Error Amplifier

The error amplifier compares the FB pin voltage with the internal FB reference (V_{FB}) and outputs a current proportional to the difference between the two. This output current is then used to charge or discharge the internal compensation network to form the COMP voltage, which is used to control the power MOSFET current. The optimized internal compensation network minimizes the external component counts and simplifies the control loop design.

Internal Soft-Start

The soft-start is important for many applications because it eliminates power-up initialization problems. The controlled voltage ramp of the output also reduces peak inrush current during start-up, minimizing start-up transient events to the input power bus.

Over-Current-Protection and Hiccup

The HM1470H has a cycle-by-cycle over-current limit for when the inductor current peak value exceeds the set current-limit threshold. First, when the output voltage drops until FB falls below the Under-Voltage (UV) threshold (typically 140mV) to trigger a UV event, the HM1470H enters hiccup mode to periodically restart the part. This protection mode is especially useful when the output is dead-shortened to ground. This greatly reduces the average short-circuit current to alleviate thermal issues and to protect the regulator. The HM1470H exits hiccup mode once the overcurrent condition is removed.

Startup and Shutdown

If both VIN and EN are higher than their appropriate thresholds, the chip starts. The reference block

starts first, generating stable reference voltage and currents, and then the internal regulator is enabled. The regulator provides stable supply for the remaining circuitries. Three events can shut down the chip: EN low, VIN low and thermal shutdown. In the shutdown procedure, the signaling path is first blocked to avoid any fault triggering. The COMP voltage and the internal supply rail are then pulled down. The floating driver is not subject to this shutdown command.

APPLICATIONS INFORMATION

Setting Output Voltages

The external resistor divider is used to set the output voltage (see Typical Application on page 1). The feedback resistor R1 also sets the feedback loop bandwidth with the internal compensation capacitor. Choose R1 to be around 300kΩ for optimal transient response. R2 is then given by:

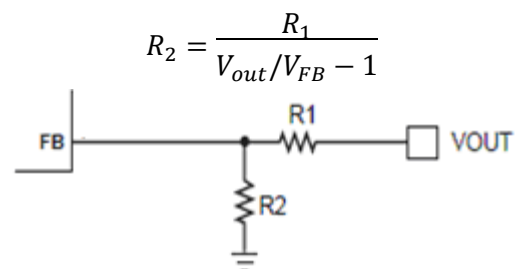

Selecting the Inductor

Use a 2.2μH-to-10μH inductor with a DC current rating of at least 25% percent higher than the maximum load current for most applications. For highest efficiency, select an inductor with a DC resistance less than 15mΩ. For most designs, derive the inductance value from the following equation.

$$L = \frac{V_{OUT} \times (V_{IN} - V_{OUT})}{V_{IN} \times \Delta I_L \times f_{osc}}$$

Where ΔI_L is the inductor ripple current. Choose an inductor current approximately 30% of the maximum load current. The maximum inductor peak current is:

$$I_{L(MAX)} = I_{LOAD} + \frac{\Delta I_L}{2}$$

Under light-load conditions (below 100mA), use a larger inductor to improve efficiency.

Selecting the Output Capacitor

The output capacitor (C2) maintains the DC output voltage. Use ceramic, tantalum, or low-ESR electrolytic capacitors. Use low ESR capacitors to limit the output voltage ripple. Estimate the output voltage ripple with:

$$\Delta V_{OUT} = \frac{V_{OUT}}{f_s \times L} \times \left[1 - \frac{V_{OUT}}{V_{IN}} \right] \times \left[R_{ESR} + \frac{1}{8 \times f_s \times C_2} \right]$$

Where L is the inductor value and R_{ESR} is the equivalent series resistance (ESR) of the output capacitor.

For ceramic capacitors, the capacitance dominates the impedance at the switching frequency and causes most of the output voltage ripple. For simplification, estimate the output voltage ripple with:

$$\Delta V_{OUT} = \frac{V_{OUT}}{8 \times f_s^2 \times L \times C_2} \times \left[1 - \frac{V_{OUT}}{V_{IN}} \right]$$

For tantalum or electrolytic capacitors, the ESR dominates the impedance at the switching frequency. For simplification, the output ripple can be approximated with:

$$\Delta V_{OUT} = \frac{V_{OUT}}{f_s \times L} \times \left[1 - \frac{V_{OUT}}{V_{IN}} \right] \times R_{ESR}$$

The characteristics of the output capacitor also affect the stability of the regulation system. The HM1470H can be optimized for a wide range of capacitance and ESR values.

PC BOARD LAYOUT

PCB layout is very important to achieve stable operation. For best results, use the following guidelines and figures as reference.

- 1) Keep the connection between the input ground and GND pin as short and wide as possible.
- 2) Keep the connection between the input capacitor and VIN pin as short and wide as possible.
- 3) Use short and direct feedback connections. Place the feedback resistors and compensation components as close to the chip as possible.
- 4) Route SW away from sensitive analog areas such as FB.

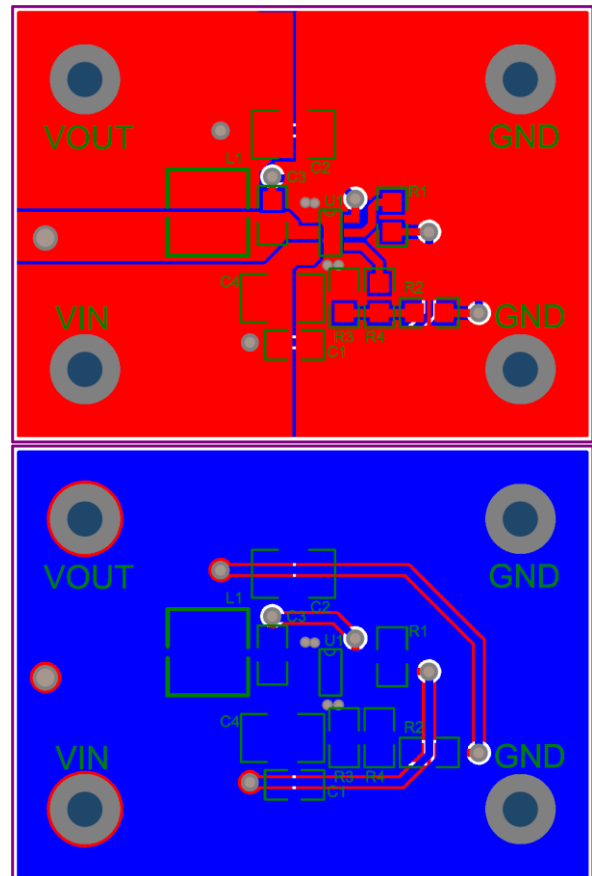

TYPICAL APPLICATION CIRCUITS

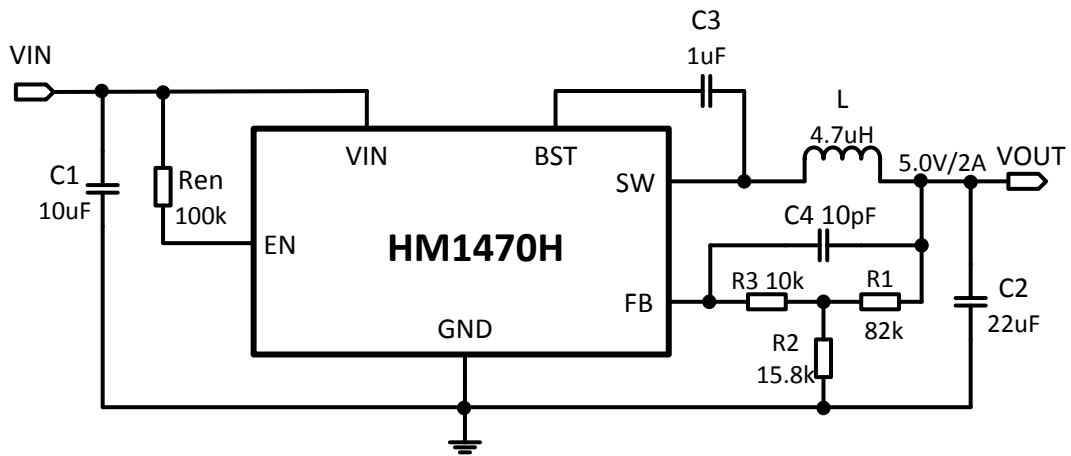

Figure3. 12V VIN, 5V/2A

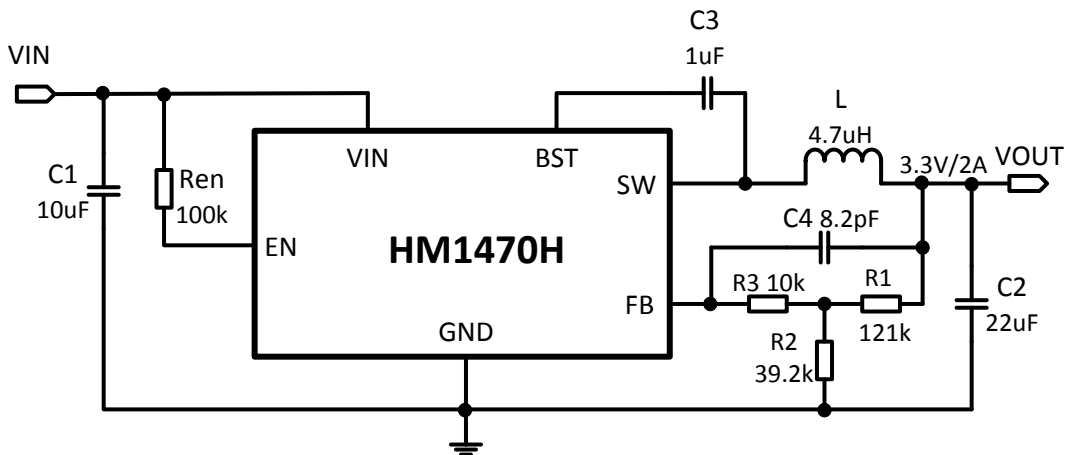

Figure4. 12V VIN, 3.3V/2A

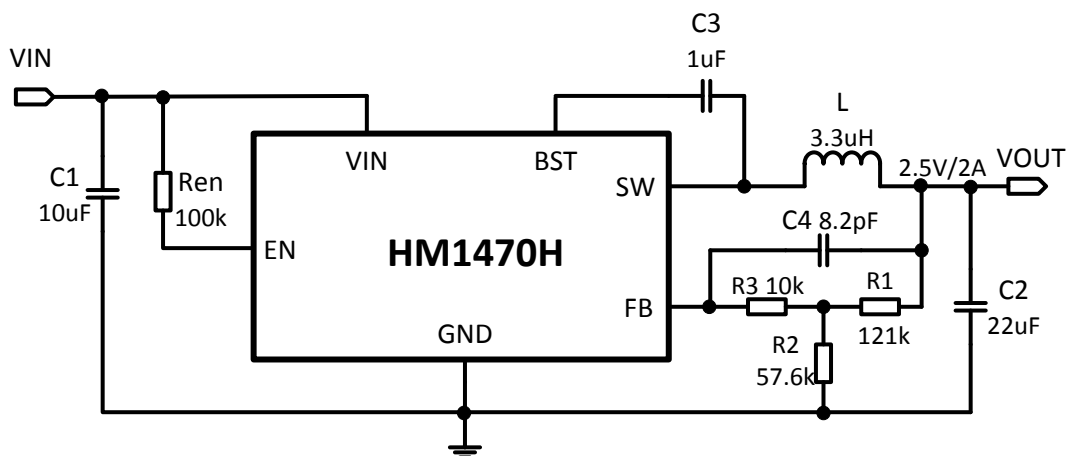

Figure5. 12V VIN, 2.5V/2A

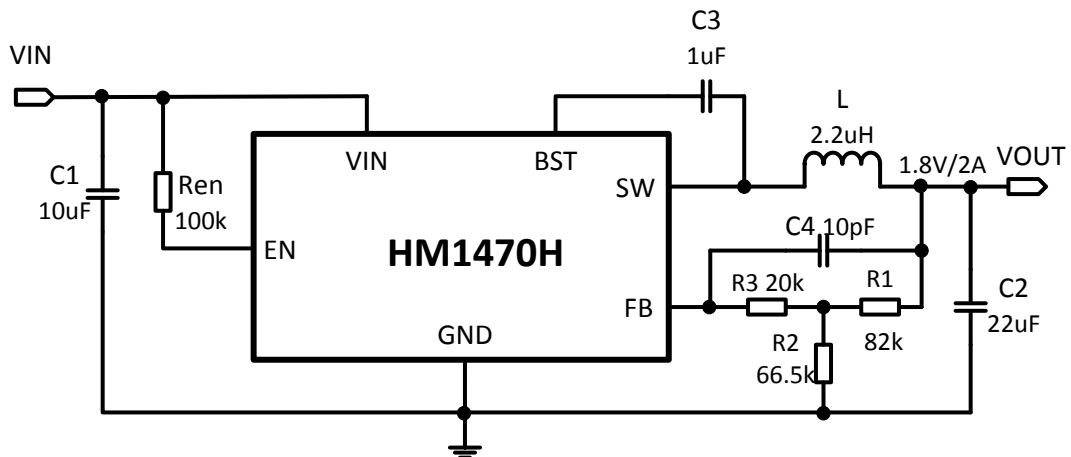

Figure6. 12V VIN, 1.8V/2A

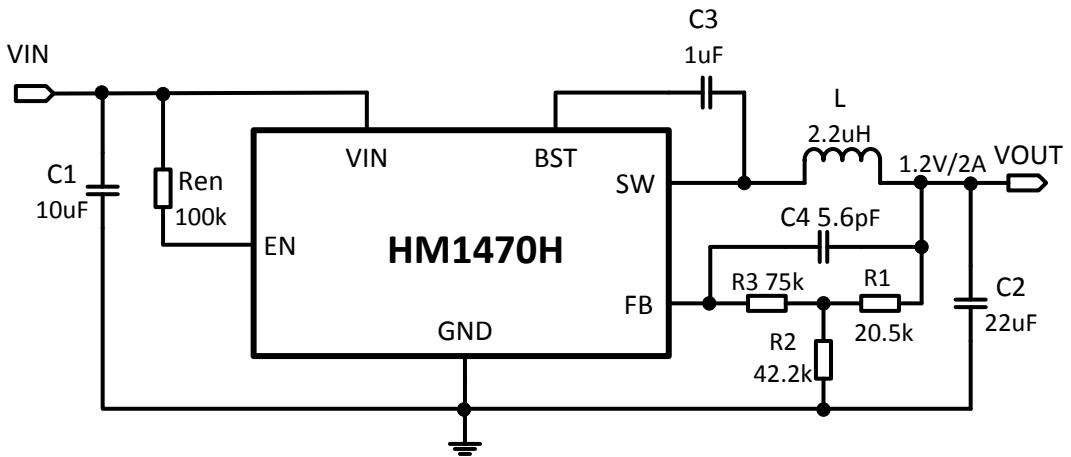

Figure7. 12V VIN, 1.2V/2A

PACKAGE OUTLINE

Package	SOT23-6	Devices per reel	3000	Unit	mm
Package specification:					