HM514100D Series

4,194,304-word × 1-bit Dynamic RAM

HITACHI

ADE-203-680 (Z)
Preliminary
Rev. 0.0
Dec. 3, 1996

Description

The Hitachi HM514100D is a CMOS dynamic RAM organized 4,194,304 word × 1-bit. HM514100D has realized higher density, higher performance and various functions by employing 0.8 μm CMOS process technology and some new CMOS circuit design technologies. The HM514100D offers Fast Page Mode as a high speed access mode. Multiplexed address input permits the HM514100D to be packaged in standard 300-mil 26-pin plastic SOJ and 26-pin plastic TSOP II.

Features

- Single 5 V (±10%)
- High speed
 - Access time : 60 ns/70 ns/80 ns (max)
- Low power dissipation
 - Active mode : 605 mW/550 mW/495 mW (max)
 - Standby mode : 11 mW (max)
0.55 mW (max) (L-version)
- Fast page mode capability
- 1024 refresh cycles : 16 ms
: 128 ms (L-version)
- 3 variations of refresh
 - $\overline{\text{RAS}}$ -only refresh
 - $\overline{\text{CAS}}$ -before- $\overline{\text{RAS}}$ refresh
 - Hidden refresh
- Test function
- Battery backup operation (L-version)

Preliminary: This document contains information on a new product. Specifications and information contained herein are subject to change without notice.

HM514100D Series

Ordering Information

Type No.	Access time	Package
HM514100DS-6	60 ns	300-mil 26-pin plastic SOJ (CP-26/20D)
HM514100DS-7	70 ns	
HM514100DS-8	80 ns	
HM514100DLS-6	60 ns	
HM514100DLS-7	70 ns	
HM514100DLS-8	80 ns	
HM514100DTT-6	60 ns	26-pin plastic TSOPII (TTP-26/20D)
HM514100DTT-7	70 ns	
HM514100DTT-8	80 ns	
HM514100DLTT-6	60 ns	
HM514100DLTT-7	70 ns	
HM514100DLTT-8	80 ns	

Pin Arrangement

HM514100CS/CLS Series

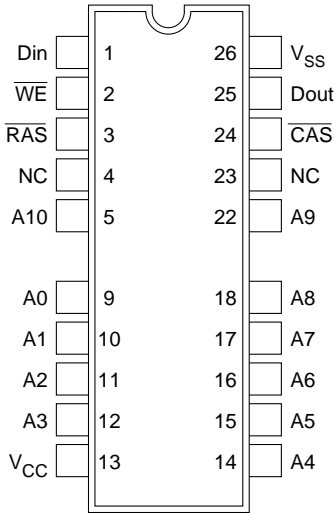

(Top view)

HM514100CTT/CLTT Series

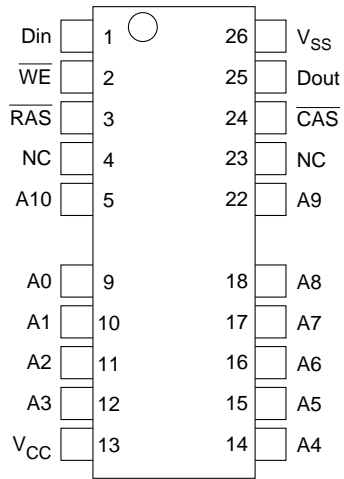

(Top view)

Pin Description

Pin name	Function
A0 to A10	Address input — Row: A0 to A10 — Column: A0 to A10 — Refresh: A0 to A9
Din	Data-in
Dout	Data-out
$\overline{\text{RAS}}$	Row address strobe
$\overline{\text{CAS}}$	Column address strobe
$\overline{\text{WE}}$	Read/Write enable
V_{CC}	Power supply
V_{SS}	Ground
NC	No connection

Block Diagram

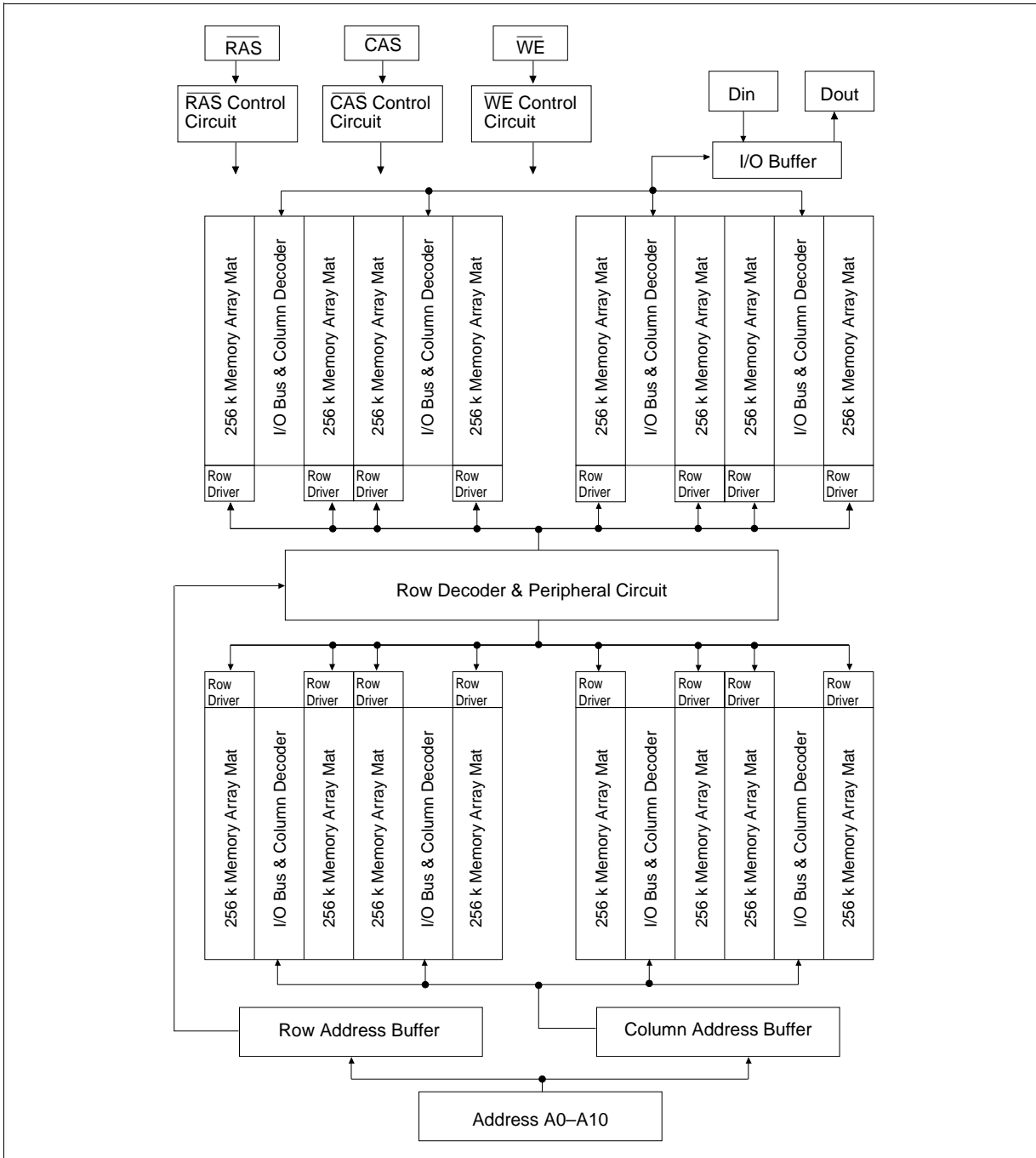

Absolute Maximum Ratings

Parameter	Symbol	Value	Unit
Voltage on any pin relative to V_{SS}	V_T	-1.0 to +7.0	V
Supply voltage relative to V_{SS}	V_{CC}	-1.0 to +7.0	V
Short circuit output current	I_{out}	50	mA
Power dissipation	P_T	1.0	W
Operating temperature	T_{opr}	0 to +70	°C
Storage temperature	T_{stg}	-55 to +125	°C

Recommended DC Operating Conditions ($T_a = 0$ to $+70^\circ\text{C}$)

Parameter	Symbol	Min	Typ	Max	Unit	Note
Supply voltage	V_{SS}	0	0	0	V	
	V_{CC}	4.5	5.0	5.5	V	1
Input high voltage	V_{IH}	2.4	—	6.5	V	1
Input low voltage	V_{IL}	-1.0	—	0.8	V	1

Note: 1. All voltage referred to V_{SS} .

HM514100D Series

DC Characteristics ($T_a = 0$ to $+70^\circ\text{C}$, $V_{CC} = 5\text{ V} \pm 10\%$, $V_{SS} = 0\text{ V}$)

Parameter	Symbol	HM514100D						Unit	Test conditions	Notes
		-6		-7		-8				
		Min	Max	Min	Max	Min	Max			
Operating current	I_{CC1}	—	110	—	100	—	90	mA	$\overline{\text{RAS}}, \overline{\text{CAS}}$ cycling $t_{RC} = \text{min}$	1, 2
Standby current	I_{CC2}	—	2	—	2	—	2	mA	TTL interface $\overline{\text{RAS}}, \overline{\text{CAS}} = V_{IH}$ Dout = High-Z	
		—	1	—	1	—	1	mA	CMOS interface $\overline{\text{RAS}}, \overline{\text{CAS}} \geq V_{CC} - 0.2\text{ V}$ Dout = High-Z	
Standby current (L-version)	I_{CC2}	—	100	—	100	—	100	μA	CMOS interface $\overline{\text{RAS}}, \overline{\text{CAS}} = V_{IH}$ WE, Address and Din = V_{IH} or V_{IL} Dout = High-Z	4
$\overline{\text{RAS}}$ -only refresh current	I_{CC3}	—	110	—	100	—	90	mA	$t_{RC} = \text{min}$	2
Standby current	I_{CC5}	—	5	—	5	—	5	mA	$\overline{\text{RAS}} = V_{IH}$, $\overline{\text{CAS}} = V_{IL}$ Dout = enable	1
$\overline{\text{CAS}}$ -before- $\overline{\text{RAS}}$ refresh current	I_{CC6}	—	110	—	100	—	90	mA	$t_{RC} = \text{min}$	
Fast page mode current	I_{CC7}	—	110	—	100	—	90	mA	$t_{PC} = \text{min}$	1, 3
Battery backup current (Standby with CBR refresh) (L-version)	I_{CC10}	—	200	—	200	—	200	μA	$t_{RC} = 125\ \mu\text{s}$ $t_{RAS} \leq 1\ \mu\text{s}$ WE = V_{IH} , $\overline{\text{CAS}} = V_{IL}$ OE Address, Din = V_{IH} or V_{IL} Dout = High-Z	4
Input leakage current	I_{LI}	-10	10	-10	10	-10	10	μA	$0\text{ V} \leq V_{in} \leq 7\text{ V}$	
Output leakage current	I_{LO}	-10	10	-10	10	-10	10	μA	$0\text{ V} \leq V_{out} \leq 7\text{ V}$ Dout = disable	
Output high voltage	V_{OH}	2.4	V_{CC}	2.4	V_{CC}	2.4	V_{CC}	V	High Iout = -5 mA	
Output low voltage	V_{OL}	0	0.4	0	0.4	0	0.4	V	Low Iout = 4.2 mA	

Notes: 1. I_{CC} depends on output load condition when the device is selected. I_{CC} max is specified at the output open condition.

2. Address can be changed twice or less while $\overline{\text{RAS}} = V_{IL}$.

3. Address can be changed once or less while $\overline{\text{CAS}} = V_{IH}$.

4. $V_{CC} - 0.2\text{ V} \leq V_{IH} \leq 6.5\text{ V}$ and $0\text{ V} \leq V_{IL} \leq 0.2\text{ V}$.

Capacitance ($T_a = 25^\circ\text{C}$, $V_{CC} = 5\text{ V} \pm 10\%$)

Parameter	Symbol	Typ	Max	Unit	Notes
Input capacitance (Address, Data-in)	C_{I1}	—	5	pF	1
Input capacitance (Clocks)	C_{I2}	—	7	pF	1
Output capacitance (Data-out)	C_O	—	7	pF	1, 2

Notes: 1. Capacitance measured with Boonton Meter or effective capacitance measuring method.
 2. $\overline{\text{RAS}}$, $\overline{\text{CAS}} = V_{IH}$ to disable Dout.

AC Characteristics ($T_a = 0$ to $+70^\circ\text{C}$, $V_{CC} = 5\text{ V} \pm 10\%$, $V_{SS} = 0\text{ V}$)^{*1, *12, *15}

Test Conditions

- Input rise and fall time : 5 ns
- Input timing reference levels : 0.8 V, 2.4 V
- Output load : 2 TTL gate + C_L (100 pF) (Including scope and jig)

Read, Write, Read-Modify-Write and Refresh Cycles (Common parameters)

Parameter	Symbol	HM514100D						Unit	Notes
		-6		-7		-8			
		Min	Max	Min	Max	Min	Max		
Random read or write cycle time	t_{RC}	110	—	130	—	150	—	ns	
$\overline{\text{RAS}}$ precharge time	t_{RP}	40	—	50	—	60	—	ns	
$\overline{\text{RAS}}$ pulse width	t_{RAS}	60	10000	70	10000	80	10000	ns	18
$\overline{\text{CAS}}$ pulse width	t_{CAS}	15	10000	20	10000	20	10000	ns	19
Row address setup time	t_{ASR}	0	—	0	—	0	—	ns	
Row address hold time	t_{RAH}	10	—	10	—	10	—	ns	
Column address setup time	t_{ASC}	0	—	0	—	0	—	ns	
Column address hold time	t_{CAH}	15	—	15	—	15	—	ns	
$\overline{\text{RAS}}$ to $\overline{\text{CAS}}$ delay time	t_{RCD}	20	45	20	50	20	60	ns	8
$\overline{\text{RAS}}$ to column address delay time	t_{RAD}	15	30	15	35	15	40	ns	9
$\overline{\text{RAS}}$ hold time	t_{RSH}	15	—	20	—	20	—	ns	
$\overline{\text{CAS}}$ hold time	t_{CSH}	60	—	70	—	80	—	ns	
$\overline{\text{CAS}}$ to $\overline{\text{RAS}}$ precharge time	t_{CRP}	10	—	10	—	10	—	ns	
Transition time (rise and fall)	t_T	3	50	3	50	3	50	ns	7
Refresh period	t_{REF}	—	16	—	16	—	16	ms	
Refresh period (L-version)	t_{REF}	—	128	—	128	—	128	ms	

HM514100D Series

Read Cycle

Parameter	Symbol	HM514100D						Unit	Notes
		-6		-7		-8			
		Min	Max	Min	Max	Min	Max		
Access time from $\overline{\text{RAS}}$	t_{RAC}	—	60	—	70	—	80	ns	2, 3, 16
Access time from $\overline{\text{CAS}}$	t_{CAC}	—	15	—	20	—	20	ns	3, 4, 14, 16
Access time from address	t_{AA}	—	30	—	35	—	40	ns	3, 5, 14, 16
Read command setup time	t_{RCS}	0	—	0	—	0	—	ns	
Read command hold time to $\overline{\text{CAS}}$	t_{RCH}	0	—	0	—	0	—	ns	17
Read command hold time to $\overline{\text{RAS}}$	t_{RRH}	0	—	0	—	0	—	ns	17
Column address to $\overline{\text{RAS}}$ lead time	t_{RAL}	30	—	35	—	40	—	ns	
Output buffer turn-off time	t_{OFF}	0	15	0	20	0	20	ns	6

Write Cycle

Parameter	Symbol	HM514100D						Unit	Notes
		-6		-7		-8			
		Min	Max	Min	Max	Min	Max		
Write command setup time	t_{WCS}	0	—	0	—	0	—	ns	10
Write command hold time	t_{WCH}	15	—	15	—	15	—	ns	
Write command pulse width	t_{WP}	10	—	10	—	10	—	ns	
Write command to $\overline{\text{RAS}}$ lead time	t_{RWL}	15	—	20	—	20	—	ns	
Write command to $\overline{\text{CAS}}$ lead time	t_{CWL}	15	—	20	—	20	—	ns	
Data-in setup time	t_{DS}	0	—	0	—	0	—	ns	11
Data-in hold time	t_{DH}	15	—	15	—	15	—	ns	11

Read-Modify-Write Cycle

Parameter	Symbol	HM514100D						Unit	Notes
		-6		-7		-8			
		Min	Max	Min	Max	Min	Max		
Read-modify-write cycle time	t_{RWC}	130	—	155	—	175	—	ns	
$\overline{\text{RAS}}$ to $\overline{\text{WE}}$ delay time	t_{RWD}	60	—	70	—	80	—	ns	10
$\overline{\text{CAS}}$ to $\overline{\text{WE}}$ delay time	t_{CWD}	15	—	20	—	20	—	ns	10
Column address to $\overline{\text{WE}}$ delay time	t_{AWD}	30	—	35	—	40	—	ns	10

Refresh Cycle

Parameter	Symbol	HM514100D						Unit	Notes
		-6		-7		-8			
		Min	Max	Min	Max	Min	Max		
$\overline{\text{CAS}}$ setup time (CBR refresh cycle)	t_{CSR}	10	—	10	—	10	—	ns	
$\overline{\text{CAS}}$ hold time (CBR refresh cycle)	t_{CHR}	10	—	10	—	10	—	ns	
$\overline{\text{RAS}}$ precharge to $\overline{\text{CAS}}$ hold time	t_{RPC}	10	—	10	—	10	—	ns	
$\overline{\text{CAS}}$ precharge time in normal mode	t_{CPN}	10	—	10	—	10	—	ns	

Fast Page Mode Cycle

Parameter	Symbol	HM514100D						Unit	Notes
		-6		-7		-8			
		Min	Max	Min	Max	Min	Max		
Fast page mode cycle time	t_{PC}	40	—	45	—	50	—	ns	
Fast page mode $\overline{\text{CAS}}$ precharge time	t_{CP}	10	—	10	—	10	—	ns	
Fast page mode $\overline{\text{RAS}}$ pulse width	t_{RASC}	—	100000	—	100000	—	100000	ns	13
Access time from $\overline{\text{CAS}}$ precharge	t_{ACP}	—	35	—	40	—	45	ns	3, 14, 16
$\overline{\text{RAS}}$ hold time from $\overline{\text{CAS}}$ precharge	t_{RHCP}	35	—	40	—	45	—	ns	

Fast Page Mode Read-Modify-Write Cycle

Parameter	Symbol	HM514100D						Unit	Notes
		-6		-7		-8			
		Min	Max	Min	Max	Min	Max		
Fast page mode read-modify-write cycle time	t_{PCM}	60	—	70	—	75	—	ns	
$\overline{\text{CAS}}$ precharge to $\overline{\text{WE}}$ delay time	t_{CPW}	35	—	40	—	45	—	ns	10

Test Mode Cycle

Parameter	Symbol	HM514100D						Unit	Notes
		-6		-7		-8			
		Min	Max	Min	Max	Min	Max		
Test mode $\overline{\text{WE}}$ setup time	t_{WS}	0	—	0	—	0	—	ns	
Test mode $\overline{\text{WE}}$ hold time	t_{WH}	10	—	10	—	10	—	ns	

Notes: 1. AC measurements assume $t_{\tau} = 5$ ns.

2. Assumes that $t_{\text{RCD}} \leq t_{\text{RCD}}(\text{max})$ and $t_{\text{RAD}} \leq t_{\text{RAD}}(\text{max})$. If t_{RCD} or t_{RAD} is greater than the maximum recommended value shown in this table, t_{RAC} exceeds the value shown.
3. Measured with a load circuit equivalent to 2 TTL loads and 100 pF.
4. Assumes that $t_{\text{RCD}} \geq t_{\text{RCD}}(\text{max})$ and $t_{\text{RAD}} \leq t_{\text{RAD}}(\text{max})$.
5. Assumes that $t_{\text{RCD}} \leq t_{\text{RCD}}(\text{max})$ and $t_{\text{RAD}} \geq t_{\text{RAD}}(\text{max})$.
6. $t_{\text{OFF}}(\text{max})$ defines the time at which the output achieves the open circuit condition and is not referred to output voltage levels.
7. $V_{\text{IH}}(\text{min})$ and $V_{\text{IL}}(\text{max})$ are reference levels for measuring timing of input signals. Also, transition times are measured between V_{IH} and V_{IL} .
8. Operation with the $t_{\text{RCD}}(\text{max})$ limit insures that $t_{\text{RAC}}(\text{max})$ can be met, $t_{\text{RCD}}(\text{max})$ is specified as a reference point only, if t_{RCD} is greater than the specified $t_{\text{RCD}}(\text{max})$ limit, then access time is controlled exclusively by t_{CAC} .
9. Operation with the $t_{\text{RAD}}(\text{max})$ limit insures that $t_{\text{RAC}}(\text{max})$ can be met, $t_{\text{RAD}}(\text{max})$ is specified as a reference point only, if t_{RAD} is greater than the specified $t_{\text{RAD}}(\text{max})$ limit, then access time is controlled exclusively by t_{AA} .
10. t_{WCS} , t_{RWD} , t_{CWD} , t_{AWD} and t_{CPW} are not restrictive operating parameters. They are included in the data sheet as electrical characteristics only; if $t_{\text{WCS}} \geq t_{\text{WCS}}(\text{min})$, the cycle is an early write cycle and the data out pin will remain open circuit (high impedance) throughout the entire cycle; if $t_{\text{RWD}} \geq t_{\text{RWD}}(\text{min})$, $t_{\text{CWD}} \geq t_{\text{CWD}}(\text{min})$, $t_{\text{AWD}} \geq t_{\text{AWD}}(\text{min})$ and $t_{\text{CPW}} \geq t_{\text{CPW}}(\text{min})$, the cycle is a read-modify-write and the data output will contain data read from the selected cell; if neither of the above sets of conditions is satisfied, the condition of the data out (at access time) is indeterminate.
11. These parameters are referred to $\overline{\text{CAS}}$ leading edge in an early write cycle and to $\overline{\text{WE}}$ leading edge in a delayed write or read-modify-write cycle.
12. An initial pause of 100 μs is required after power up followed by a minimum of eight initialization cycles ($\overline{\text{RAS}}$ -only refresh cycle or $\overline{\text{CAS}}$ -before- $\overline{\text{RAS}}$ refresh cycle). If the internal refresh counter is used, a minimum of eight $\overline{\text{CAS}}$ -before- $\overline{\text{RAS}}$ refresh cycles is required.
13. t_{RASC} defines $\overline{\text{RAS}}$ pulse width in fast page mode cycles.
14. Access time is determined by the longest among t_{AA} , t_{CAC} and t_{ACP} .
15. Test mode operation specified in this data sheet is 8-bit test function controlled by control address bits - - - RA10, CA10 and CA0. This test mode operation can be performed by $\overline{\text{WE}}$ -and- $\overline{\text{CAS}}$ -before- $\overline{\text{RAS}}$ (WCBR) refresh cycle. Refresh during test mode operation will be performed by normal read cycles or by WCBR refresh cycles. When the state of eight test bits accord each other, the condition of the output data is high level. When the state of test bits do not accord, the condition of the output data is low level. Data output pin is $\overline{\text{Dout}}$ and data input pin is $\overline{\text{Din}}$. In order to end this test mode operation, perform a $\overline{\text{CAS}}$ -before- $\overline{\text{RAS}}$ refresh cycle or a $\overline{\text{RAS}}$ -only refresh cycle.
16. In a test mode read cycle, the value of t_{RAC} , t_{AA} , t_{CAC} and t_{ACP} is delayed for 2 ns to 5 ns for the specified value. These parameters should be specified in test mode cycles by adding the above value to the specified value in this data sheet.
17. Either t_{RCH} or t_{RRH} must be satisfied
18. $t_{\text{RAS}}(\text{min}) = t_{\text{RWD}}(\text{min}) + t_{\text{RWL}}(\text{min}) + t_{\tau}$ in read-modify-write cycle.
19. $t_{\text{CAS}}(\text{min}) = t_{\text{CWD}}(\text{min}) + t_{\text{CWL}}(\text{min}) + t_{\tau}$ in read-modify-write cycle.
20. XXX: H or L (H: $V_{\text{IH}}(\text{min}) \leq V_{\text{IN}} \leq V_{\text{IH}}(\text{max})$, L: $V_{\text{IL}}(\text{min}) \leq V_{\text{IN}} \leq V_{\text{IL}}(\text{max})$)

///////: Invalid $\overline{\text{Dout}}$

When the address, clock and input pins are not described on timing waveforms, their pins must be applied V_{IH} or V_{IL} .

Timing Waveforms*20

Read Cycle

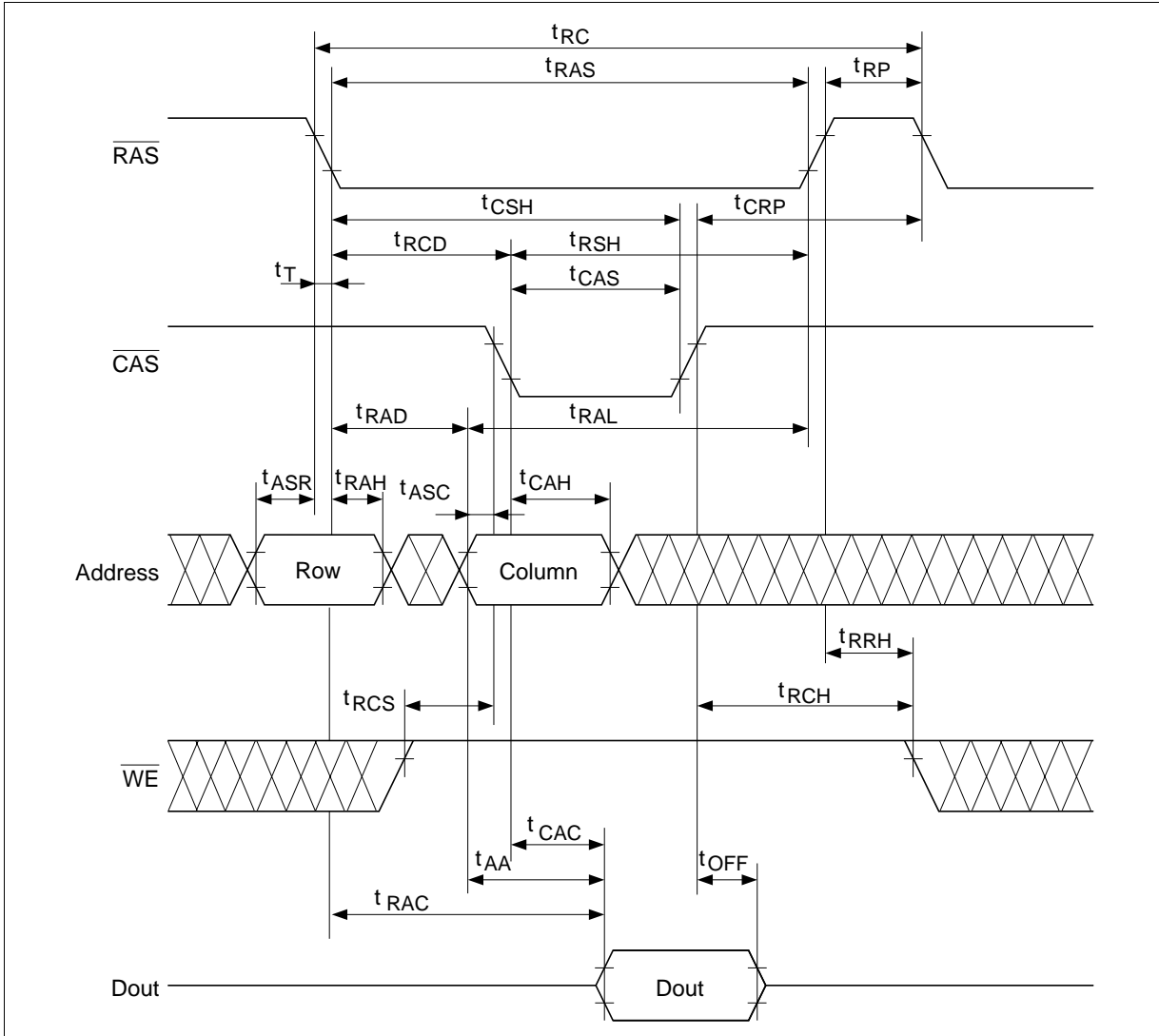

Early Write Cycle

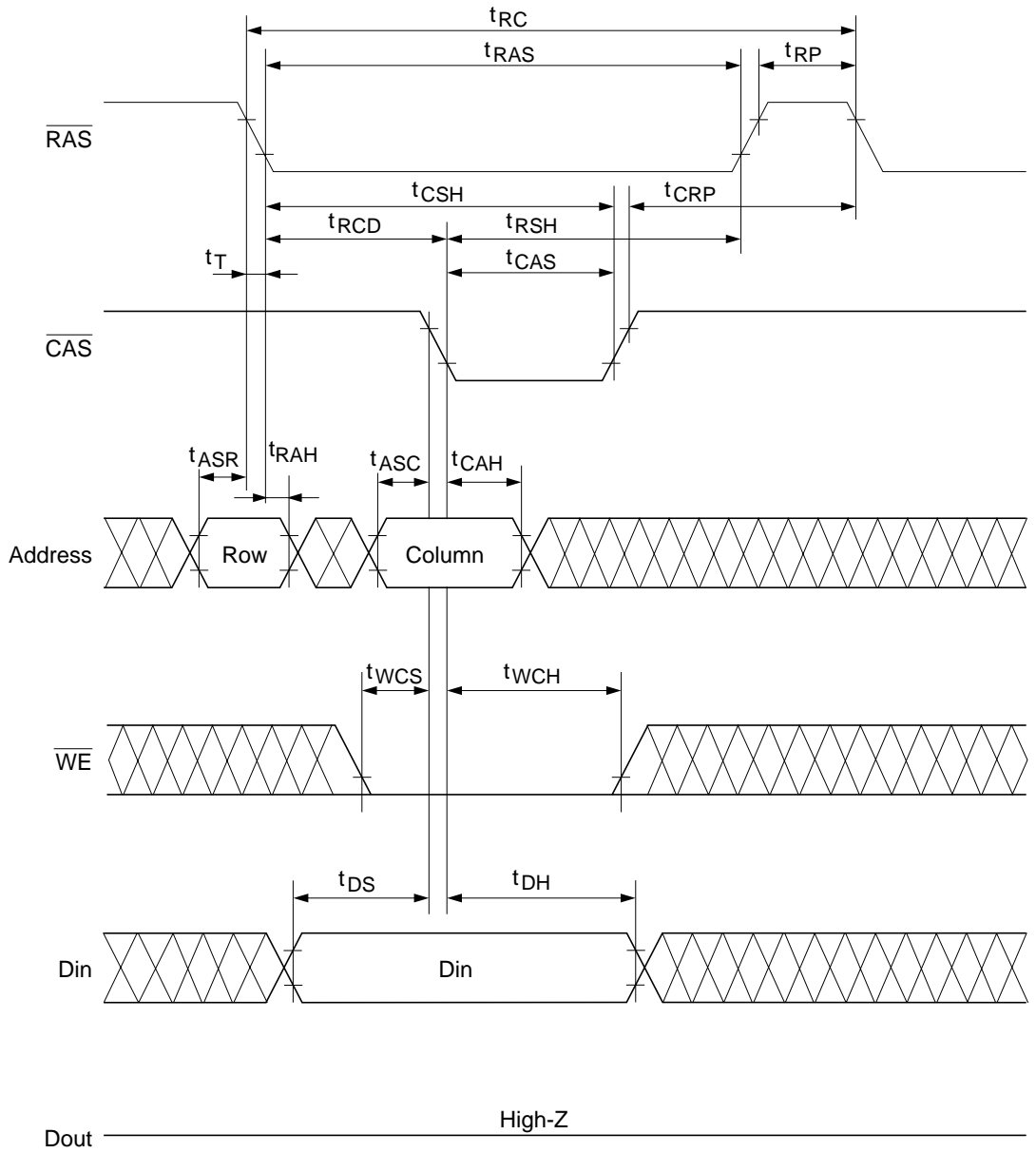

* $t_{WCS} \geq t_{WCS}(\text{min})$

Delayed Write Cycle

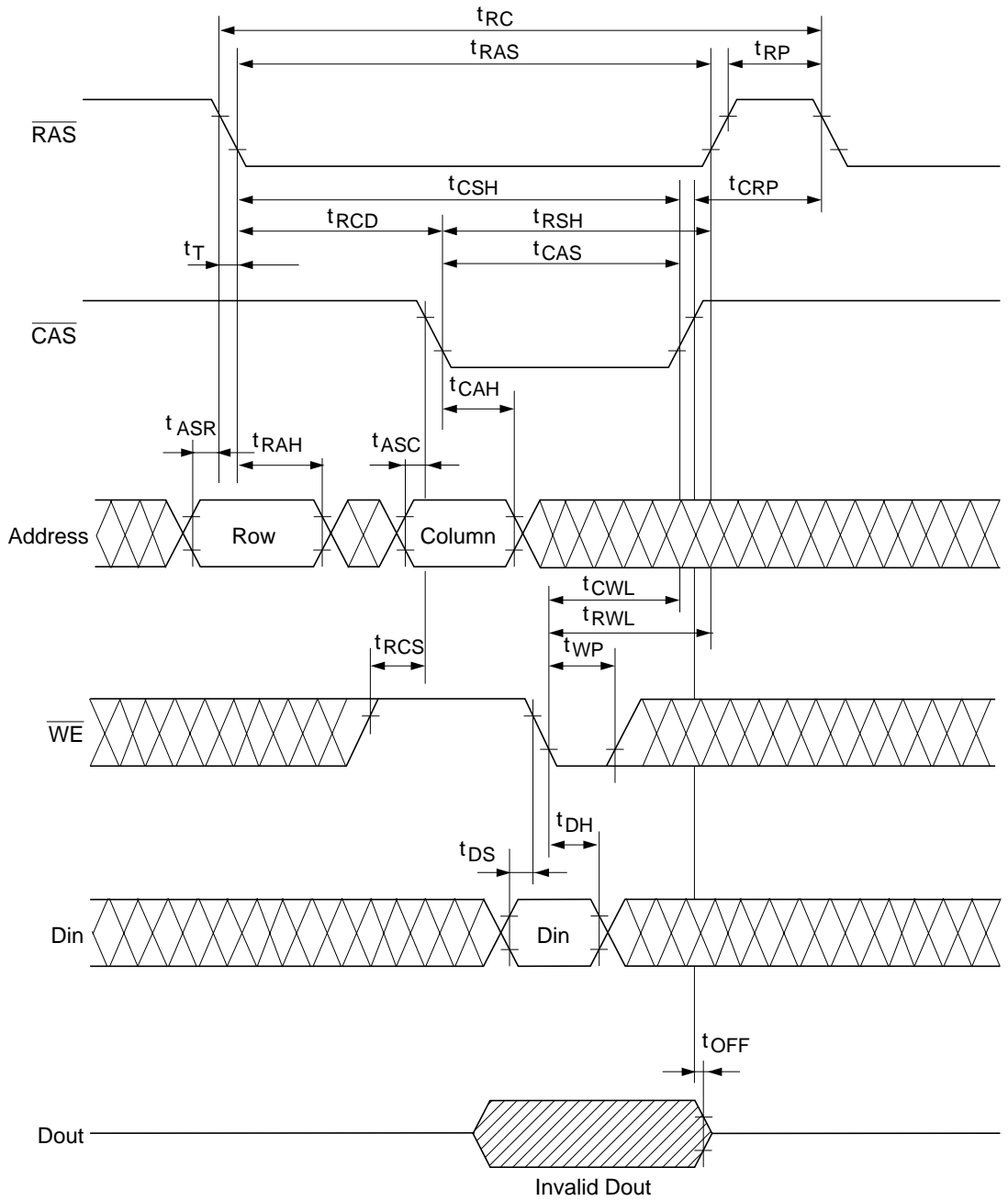

Read-Modify-Write Cycle

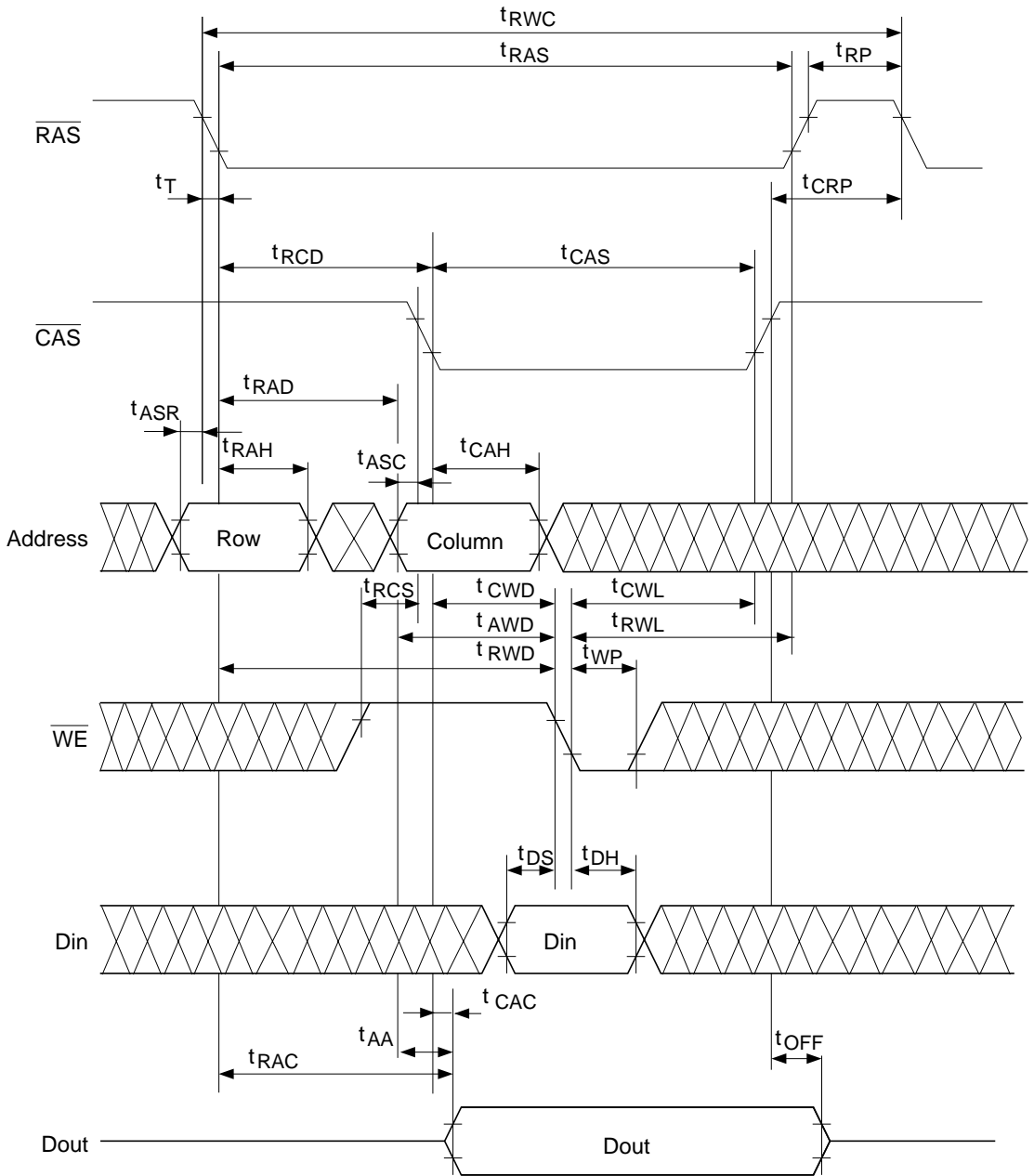

RAS-Only Refresh Cycle

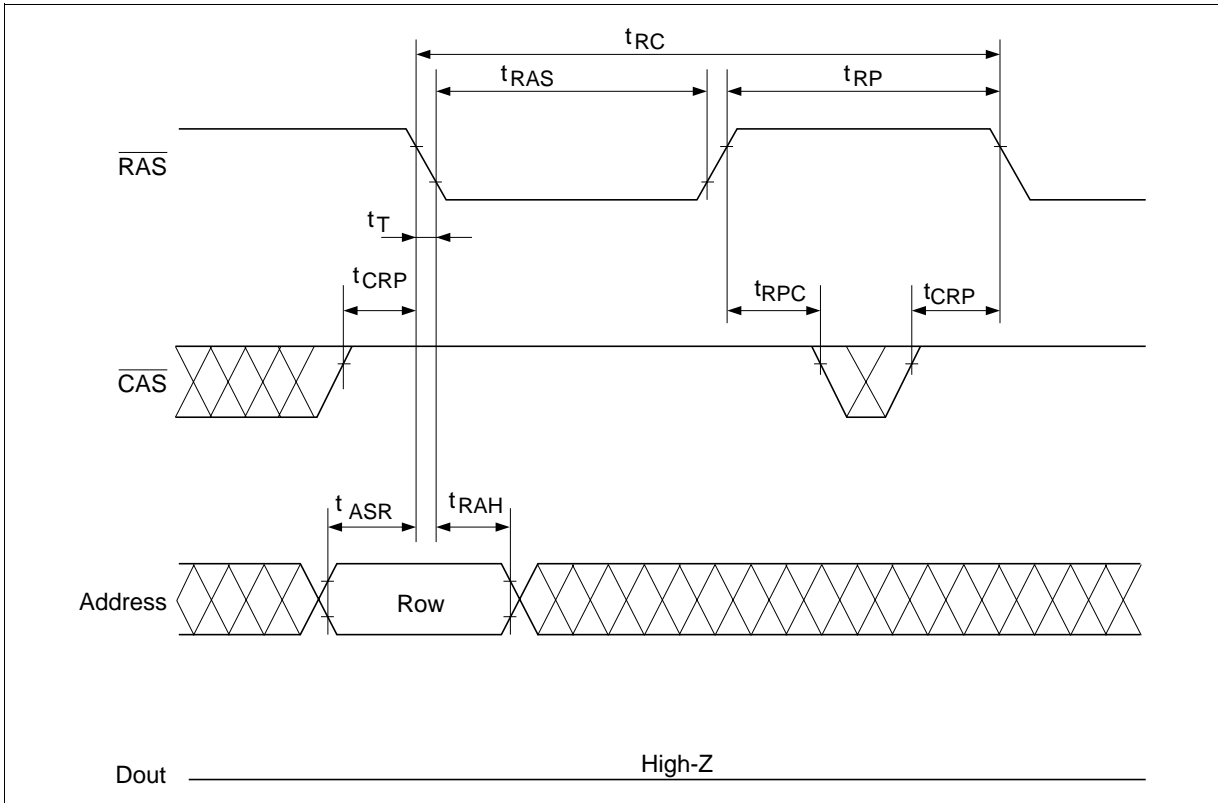

HM514100D Series

CAS-Before-RAS Refresh Cycle

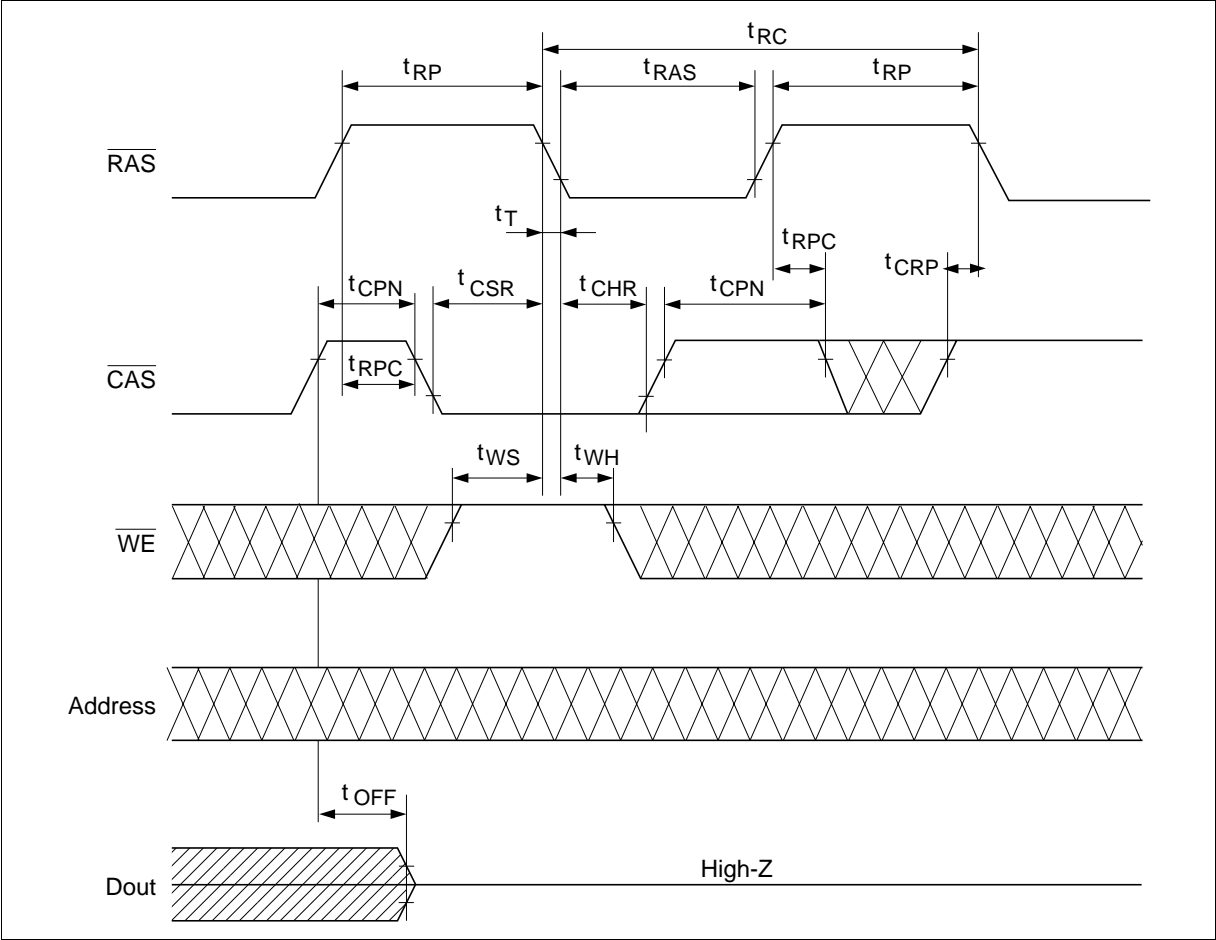

Fast Page Mode Read Cycle

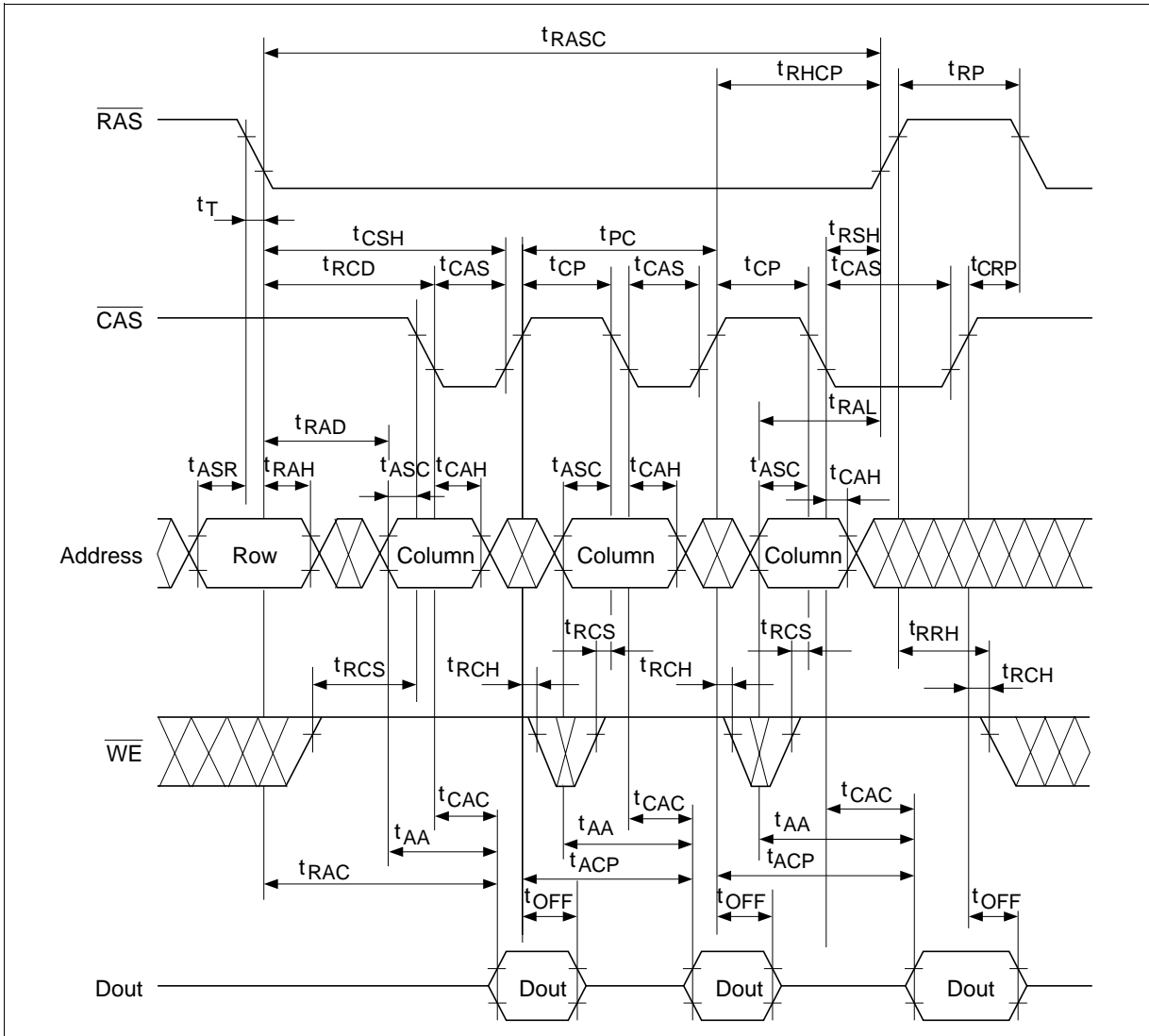

Fast Page Mode Delayed Write Cycle

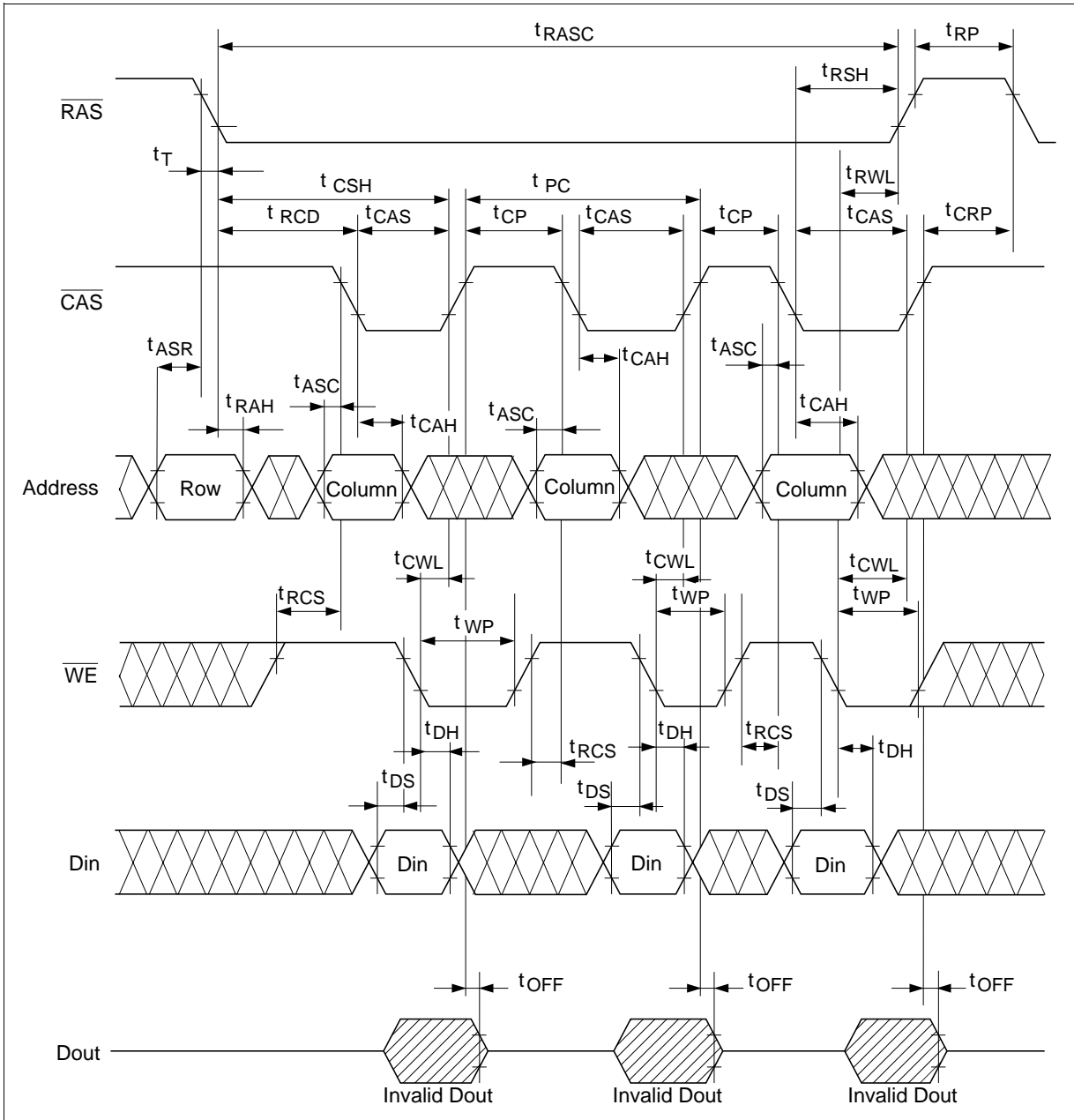

Fast Page Mode Read-Modify-Write Cycle

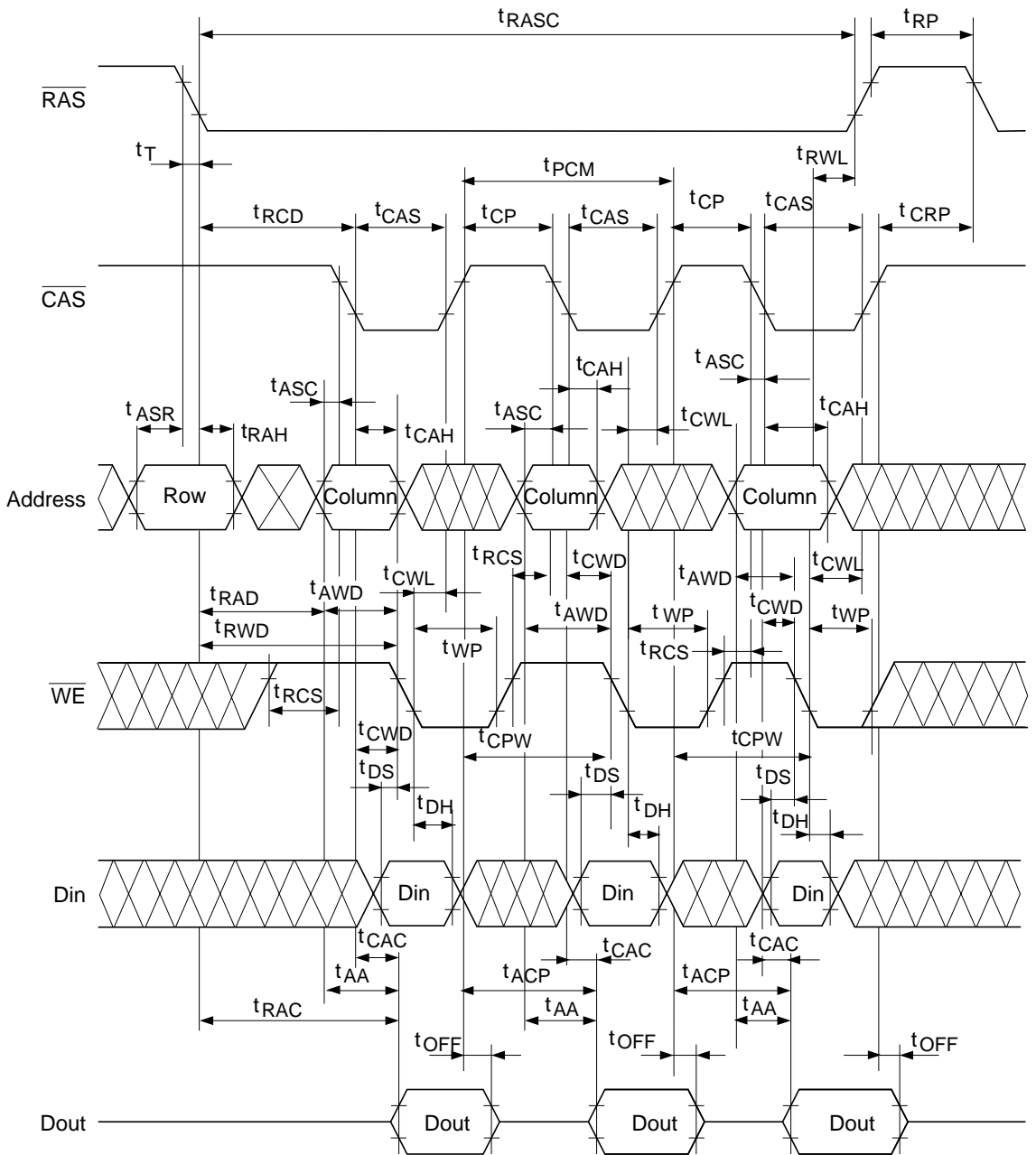

Test Mode Cycle

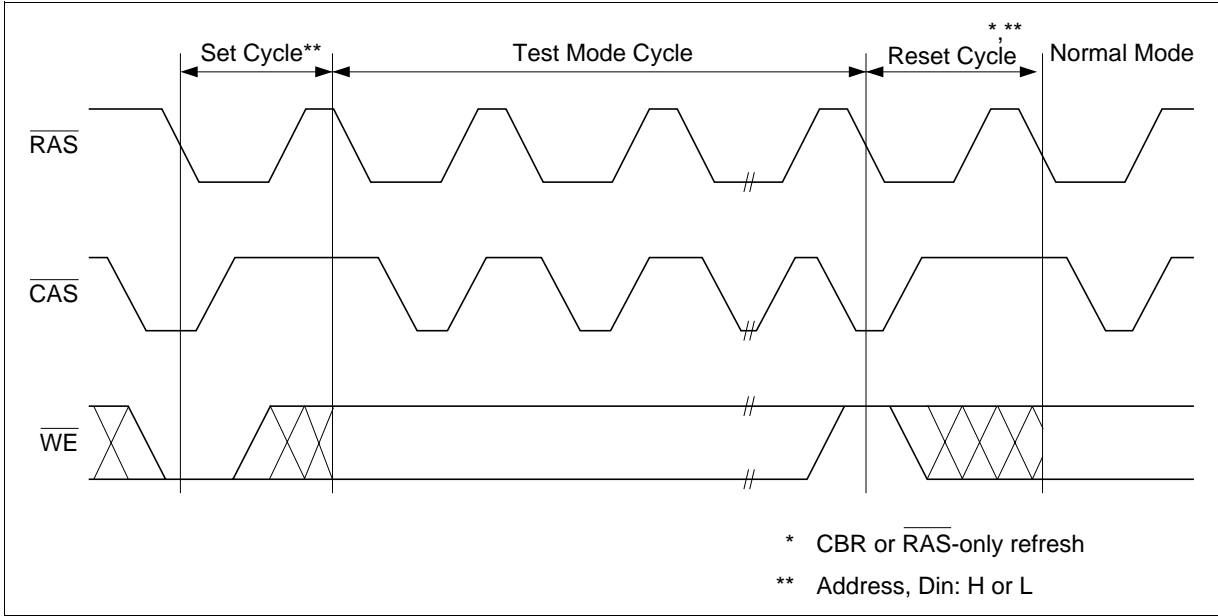

Test Mode Set Cycle

$\overline{\text{WE}}$ -and- $\overline{\text{CAS}}$ -Before $\overline{\text{RAS}}$ -Refresh

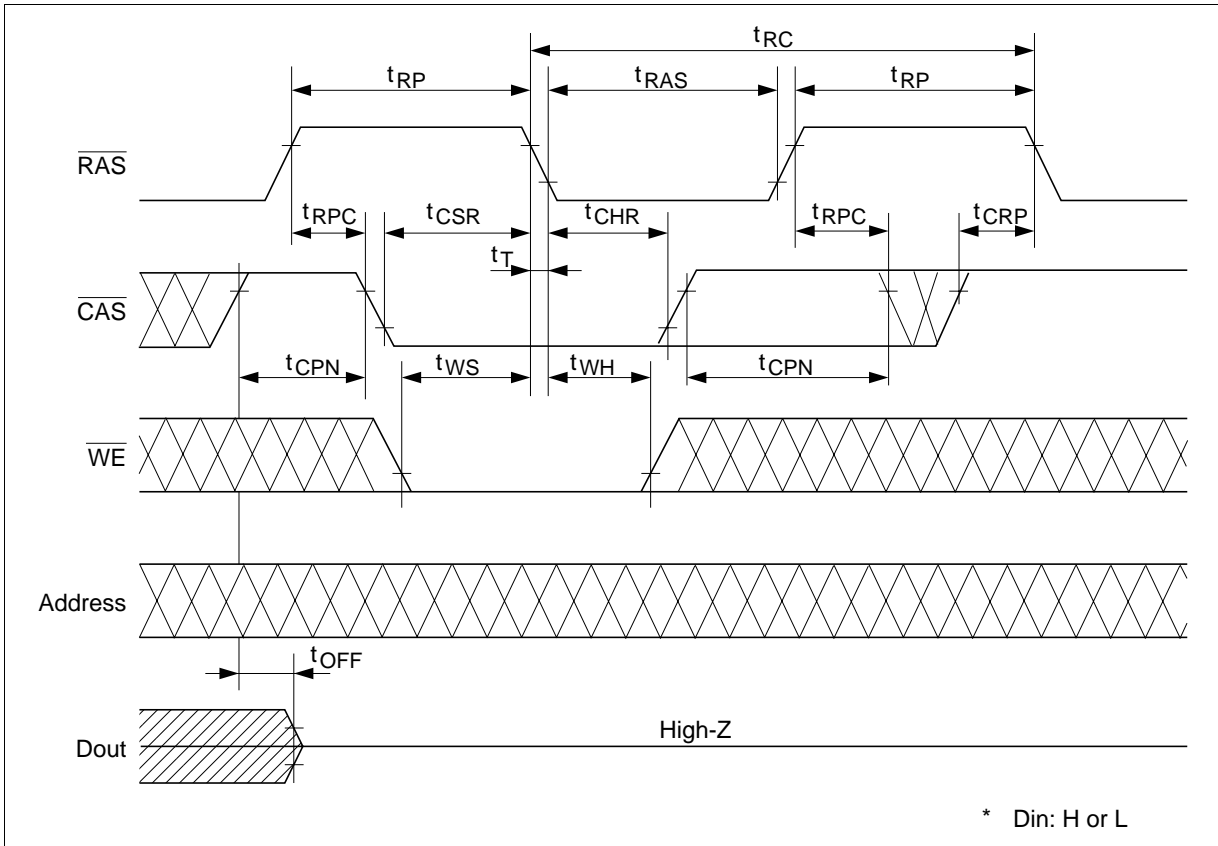

HM514100D Series

Package Dimensions

HM514100DS/DLS Series (CP-26/20D)

Unit: mm

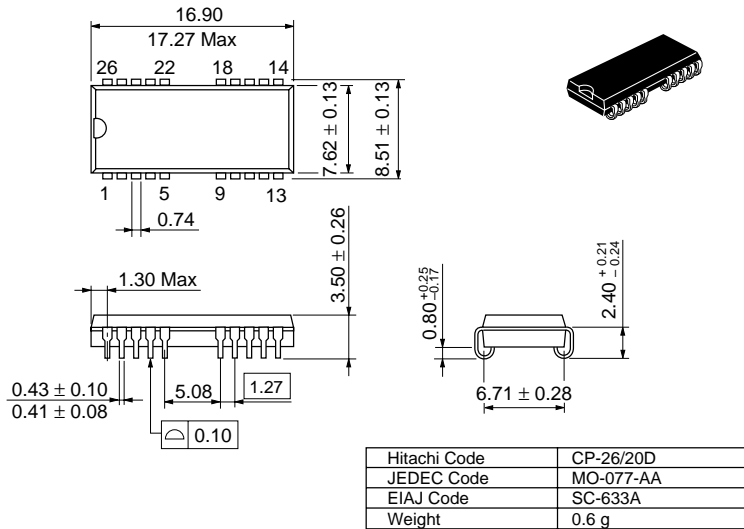

HM514100DTT/DLTT Series (TTP-26/20D)

Unit: mm

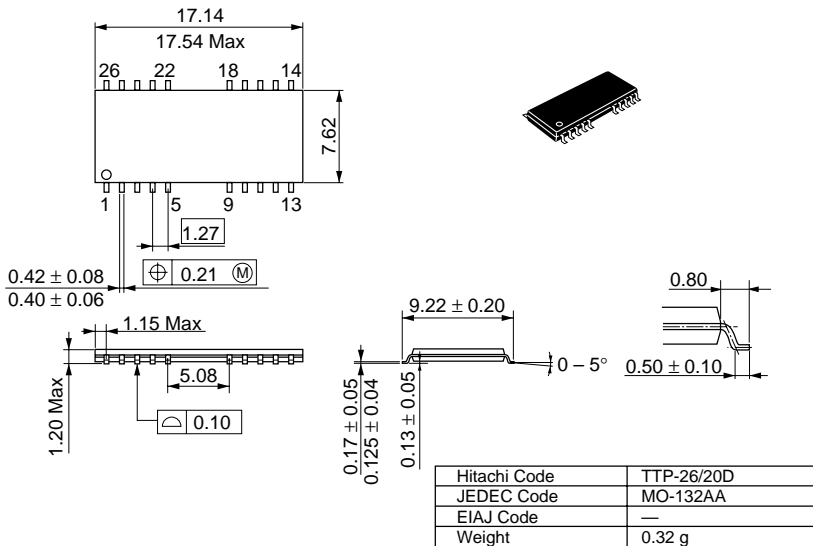

When using this document, keep the following in mind:

1. This document may, wholly or partially, be subject to change without notice.
2. All rights are reserved: No one is permitted to reproduce or duplicate, in any form, the whole or part of this document without Hitachi's permission.
3. Hitachi will not be held responsible for any damage to the user that may result from accidents or any other reasons during operation of the user's unit according to this document.
4. Circuitry and other examples described herein are meant merely to indicate the characteristics and performance of Hitachi's semiconductor products. Hitachi assumes no responsibility for any intellectual property claims or other problems that may result from applications based on the examples described herein.
5. No license is granted by implication or otherwise under any patents or other rights of any third party or Hitachi, Ltd.
6. **MEDICAL APPLICATIONS:** Hitachi's products are not authorized for use in **MEDICAL APPLICATIONS** without the written consent of the appropriate officer of Hitachi's sales company. Such use includes, but is not limited to, use in life support systems. Buyers of Hitachi's products are requested to notify the relevant Hitachi sales offices when planning to use the products in **MEDICAL APPLICATIONS**.

HITACHI

Hitachi, Ltd.

Semiconductor & IC Div.
Nippon Bldg., 2-6-2, Ohte-machi, Chiyoda-ku, Tokyo 100, Japan
Tel: Tokyo (03) 3270-2111
Fax: (03) 3270-5109

For further information write to:

Hitachi America, Ltd.
Semiconductor & IC Div.
2000 Sierra Point Parkway
Brisbane, CA. 94005-1835
U S A
Tel: 415-589-8300
Fax: 415-583-4207

Hitachi Europe GmbH
Electronic Components Group
Continental Europe
Dornacher Straße 3
D-85622 Feldkirchen
München
Tel: 089-9 91 80-0
Fax: 089-9 29 30 00

Hitachi Europe Ltd.
Electronic Components Div.
Northern Europe Headquarters
Whitebrook Park
Lower Cookham Road
Maidenhead
Berkshire SL6 8YA
United Kingdom
Tel: 0628-585000
Fax: 0628-778322

Hitachi Asia Pte. Ltd.
16 Collyer Quay #20-00
Hitachi Tower
Singapore 0104
Tel: 535-2100
Fax: 535-1533

Hitachi Asia (Hong Kong) Ltd.
Unit 706, North Tower,
World Finance Centre,
Harbour City, Canton Road
Tsim Sha Tsui, Kowloon
Hong Kong
Tel: 27359218
Fax: 27306071

HM514100D Series

Revision Record

Rev.	Date	Contents of Modification	Drawn by	Approved by
0.0	Dec. 3, 1996	Initial issue		
