

GaAs MMIC SPDT NON-REFLECTIVE SWITCH, DC - 12.0 GHz

Typical Applications

The HMC232LP4 is ideal for:

- Telecom Infrastructure
- Microwave Radio & VSAT
- Military Radios, Radar & ECM
- Test Instrumentation

Features

- Isolation: 60 dB @ 3 GHz
52 dB @ 6 GHz
- +27 dBm Input P1dB
- Insertion Loss: 1.5 dB Typical @ 6 GHz
- Non-Reflective Design
- 4 x 4 x 1 mm QFN SMT Package

Functional Diagram

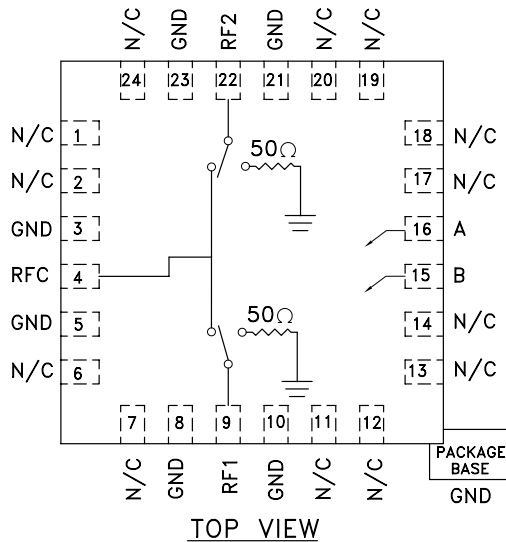

General Description

The HMC232LP4 is a broadband high isolation non-reflective GaAs MESFET SPDT switch in a low cost leadless QFN surface mount plastic package. Covering DC to 12 GHz, the switch features >60 dB isolation up to 3 GHz and >42 dB isolation up to 12 GHz. Input P1dB compression is +27 dBm typical, while input IP3 is +50 dBm. The switch operates using complementary negative control voltage logic lines of -5/0V and requires no bias supply.

Electrical Specifications, $T_A = +25^\circ\text{C}$, With 0/-5V Control, 50 Ohm System

Parameter	Frequency	Min.	Typ.	Max.	Units
Insertion Loss	DC - 3.0 GHz		1.4	1.7	dB
	DC - 6.0 GHz		1.5	1.8	dB
	DC - 9.0 GHz		2.0	2.3	dB
	DC - 12.0 GHz		2.7	3.1	dB
Isolation	DC - 3.0 GHz	55	60		dB
	DC - 6.0 GHz	47	52		dB
	DC - 9.0 GHz	40	45		dB
	DC - 12.0 GHz	37	42		dB
Return Loss	"On State"	DC - 6.0 GHz		18	dB
		DC - 9.0 GHz		16	dB
		DC - 12.0 GHz		11	dB
Return Loss RF1, RF2	"Off State"	DC - 12.0 GHz		14	dB
Input Power for 1 dB Compression	0.5 - 12.0 GHz	24	27		dBm
Input Third Order Intercept (Two-Tone Input Power = +7 dBm Each Tone, 1 MHz Tone Separation)	0.5 - 12.0 GHz	45	50		dBm
Switching Characteristics	DC - 12.0 GHz	tRISE, tFALL (10/90% RF)		3	ns
		tON, tOFF (50% CTL to 10/90% RF)		6	ns

For price, delivery, and to place orders, please contact Hittite Microwave Corporation:
12 Elizabeth Drive, Chelmsford, MA 01824 Phone: 978-250-3343 Fax: 978-250-3373
Order Online at www.hittite.com

GaAs MMIC SPDT NON-REFLECTIVE SWITCH, DC - 12.0 GHz

Insertion Loss

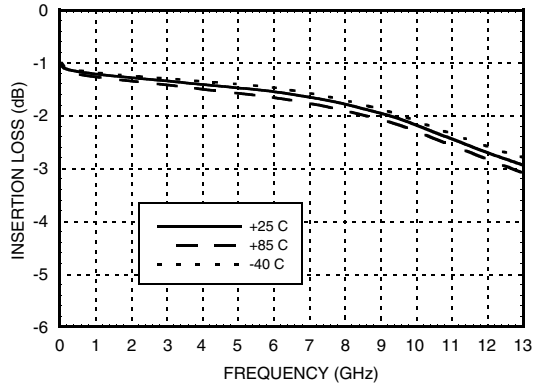

Isolation

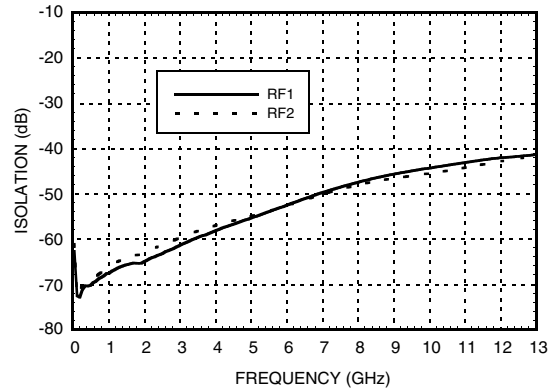

Return Loss

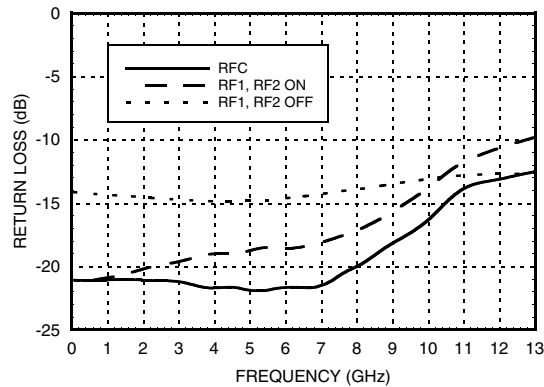

0.1 and 1 dB Input Compression Point

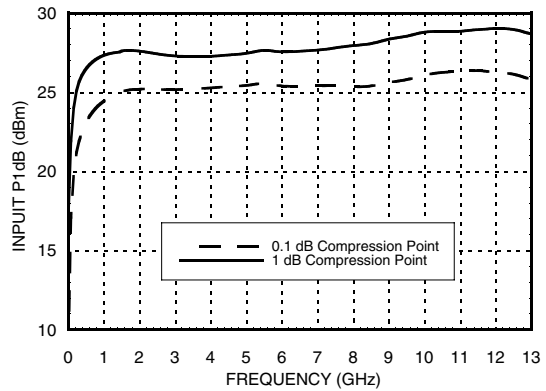

Input Third Order Intercept Point

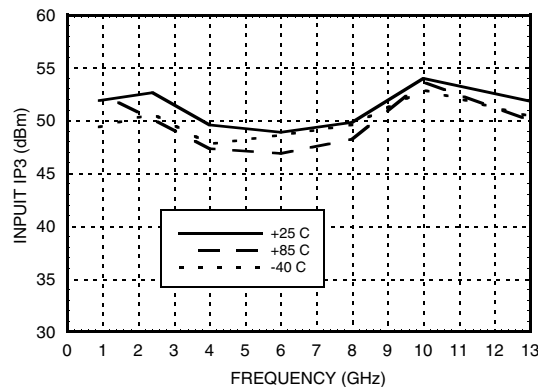

GaAs MMIC SPDT NON-REFLECTIVE SWITCH, DC - 12.0 GHz

Control Voltages

State	Bias Condition
Low	0 to -0.2V @ 10 uA Max.
High	-5V @ 10 uA Typ. to -7V @ 45 uA Typ. (± 0.5 Vdc)

Truth Table

Control Input		Signal Path State	
A	B	RFC to RF1	RFC to RF2
High	Low	ON	OFF
Low	High	OFF	ON

Absolute Maximum Ratings

RF Input Power ($V_{ctl} = -5V$) (0.5 - 12 GHz)	+30 dBm (@ +50 °C)
Control Voltage Range (A & B)	+1.0V to -7.5 Vdc
Channel Temperature	150 °C
Thermal Resistance ($R_{\theta(jc)}$) (junction to lead)	94 °C/W
Storage Temperature	-65 to +150 °C
Operating Temperature	-40 to +85 °C

Caution: Do not "Hot Switch" power levels greater than +27 dBm ($V_{ctl} = 0/-5$ Vdc).

Outline Drawing

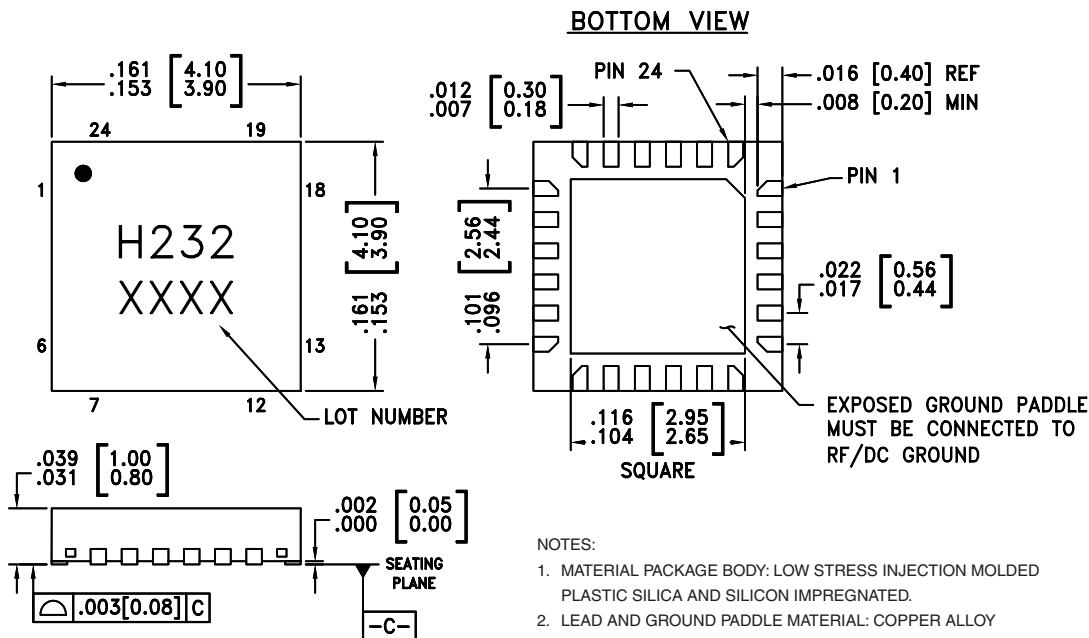

NOTES:

- MATERIAL PACKAGE BODY: LOW STRESS INJECTION MOLDED PLASTIC SILICA AND SILICON IMPREGNATED.
- LEAD AND GROUND PADDLE MATERIAL: COPPER ALLOY
- LEAD AND GROUND PADDLE PLATING: Sn/Pb SOLDER
- DIMENSIONS ARE IN INCHES [MILLIMETERS].
- LEAD SPACING TOLERANCE IS NON-CUMULATIVE
- PAD BURR LENGTH SHALL BE 0.15mm MAXIMUM. PAD BURR HEIGHT SHALL BE 0.05mm MAXIMUM.
- PACKAGE WARP SHALL NOT EXCEED 0.05mm.
- ALL GROUND LEADS AND GROUND PADDLE MUST BE SOLDERED TO PCB RF GROUND.
- REFER TO HITTITE APPLICATION NOTE FOR SUGGESTED PCB LAND PATTERN.

For price, delivery, and to place orders, please contact Hittite Microwave Corporation:
12 Elizabeth Drive, Chelmsford, MA 01824 Phone: 978-250-3343 Fax: 978-250-3373
Order Online at www.hittite.com

GaAs MMIC SPDT NON-REFLECTIVE SWITCH, DC - 12.0 GHz

Suggested Driver Circuit

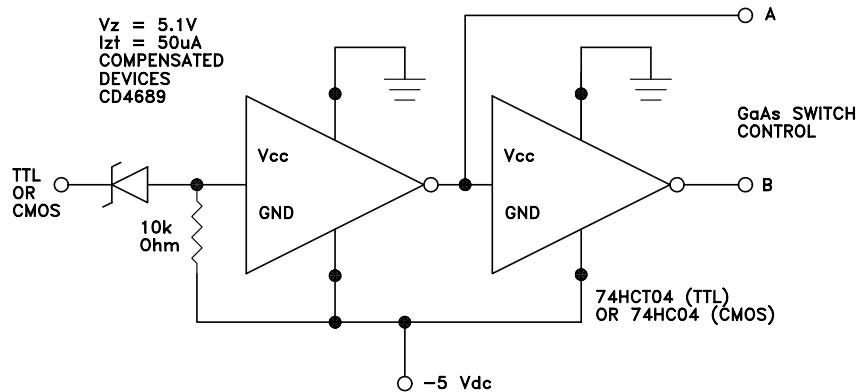

Pin Descriptions

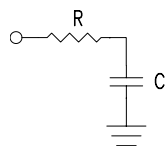
Pin Number	Function	Description	Interface Schematic
1, 2, 6, 7, 11, 12, 13, 14, 17, 18, 19, 20, 24	N/C	This pin should be connected to PCB RF ground to maximize isolation.	
3, 5, 8, 10, 21, 23	GND	Package bottom must also be connected to PCB RF ground.	
4, 9, 22	RFC, RF1, RF2	This pin is DC coupled and matched to 50 Ohm. Blocking capacitors are required if RF line potential is not equal to 0V.	
15	B	See truth table and control voltage table.	
16	A	See truth table and control voltage table.	

GaAs MMIC SPDT NON-REFLECTIVE SWITCH, DC - 12.0 GHz

Evaluation PCB

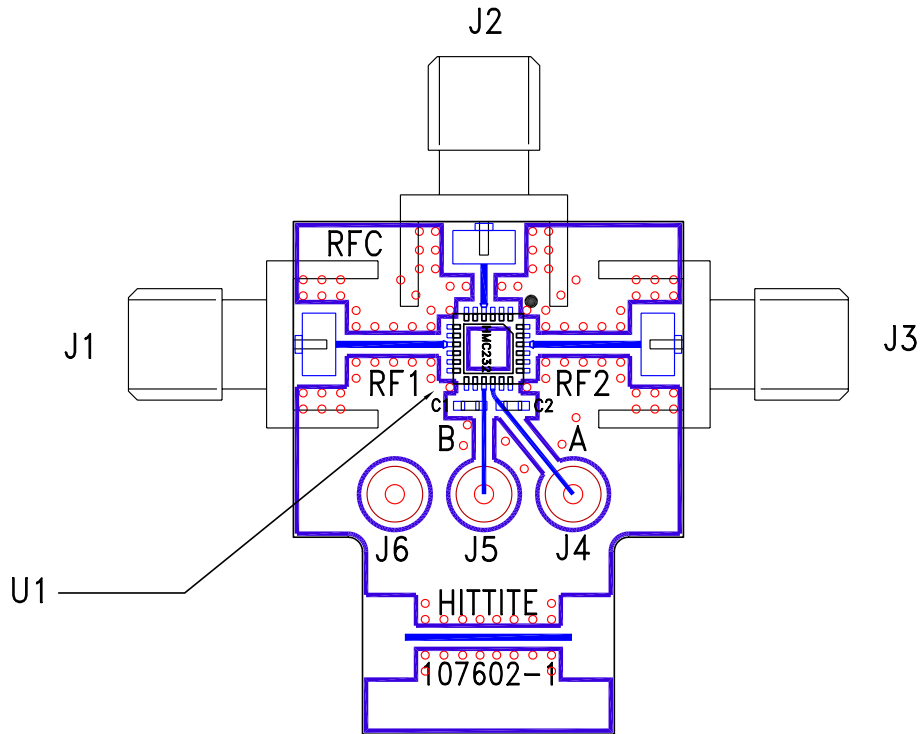

List of Material

Item	Description
J1 - J3	PC Mount SMA RF Connector
J4 - J6	DC Pin
C1, C2	100 pF, 0603 Pkg.
U1	HMC232LP4 SPDT Switch
PCB*	107602 Evaluation PCB
* Circuit Board Material: Rogers 4350	

The circuit board used in the final application should be generated with proper RF circuit design techniques. Signal lines at the RF port should have 50 ohm impedance and the package ground leads and package bottom should be connected directly to the ground plane similar to that shown above. The evaluation circuit board shown above is available from Hittite Microwave Corporation upon request.

GaAs MMIC SPDT NON-REFLECTIVE SWITCH, DC - 12.0 GHz

Notes: