

1 dB LSB GaAs MMIC 5-BIT DIGITAL ATTENUATOR, 0.7 - 3.7 GHz

Typical Applications

The HMC273MS10G is ideal for:

- Cellular
- PCS, ISM, MMDS
- WLL applications

Functional Diagram

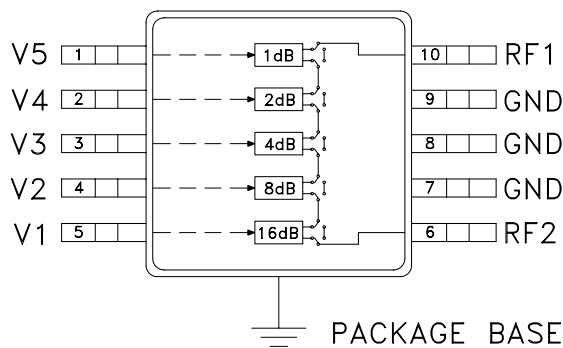

Features

- 1 dB LSB Steps to 31 dB
- Single Positive Control Per BIT
- +/- 0.5 dB Typical Bit Error
- Miniature MSOP 10 Package: 14.8mm²

General Description

The HMC273MS10G is a broadband 5-bit positive control GaAs IC digital attenuator in a 10 lead MSOP plastic package. Covering 0.7 to 3.7 GHz, the insertion loss is typically less than 2 dB. The attenuator bit values are 1 (LSB), 2, 4, 8, and 16 dB for a total attenuation of 31 dB. Accuracy is excellent at ± 0.5 dB typical with an IIP3 of up to +48 dBm. Five bit control voltage inputs, toggled between 0 and +3 to +5 volts, are used to select each attenuation state. A single Vdd bias of +3 to +5 volts applied through an external 5K Ohm resistor is required.

Electrical Specifications,

$T_A = +25^\circ C$, $V_{dd} = +3V$ to $+5V$ & $V_{ctl} = 0/V_{dd}$ (Unless Otherwise Stated)

Parameter	Frequency	Min.	Typical	Max.	Units
Insertion Loss	0.7 - 1.4 GHz		1.8	2.4	dB
	1.4 - 2.3 GHz		2.1	2.7	dB
	2.3 - 2.7 GHz		2.4	3.0	dB
	2.7 - 3.7 GHz		2.8	3.5	dB
Attenuation Range	0.7 - 3.7 GHz		31		dB
Return Loss (RF1 & RF2, All Atten. States)	0.7 - 1.4 GHz	11	17		dB
	1.4 - 2.7 GHz	14	20		dB
	2.7 - 3.7 GHz	10	14		dB
Attenuation Accuracy: (Referenced to Insertion Loss)	0.7 - 1.4 GHz	$\pm 0.35 + 3\%$ of Atten. Setting Max			dB
	1.4 - 2.3 GHz	$\pm 0.25 + 3\%$ of Atten. Setting Max			dB
	2.3 - 2.7 GHz	$\pm 0.30 + 5\%$ of Atten. Setting Max			dB
	2.7 - 3.7 GHz	$\pm 0.30 + 5\%$ of Atten. Setting Max			dB
	16 - 31 dB States	2.7 - 3.7 GHz	$\pm 0.50 + 8\%$ of Atten. Setting Max		
Input Power for 0.1 dB Compression	0.7 - 3.7 GHz	Vdd = 5V	24		dBm
		Vdd = 3V	22		dBm
Input Third Order Intercept Point (Two-tone Input Power = 0 dBm Each Tone)	0.7 - 3.7 GHz	Vdd = 5V	48		dBm
		Vdd = 3V	46		dBm
Switching Characteristics	0.7 - 3.7 GHz	tRISE, tFALL (10/90% RF)	560		ns
		tON, tOFF (50% CTL to 10/90% RF)	600		ns

1 dB LSB GaAs MMIC 5-BIT DIGITAL ATTENUATOR, 0.7 - 3.7 GHz

Insertion Loss

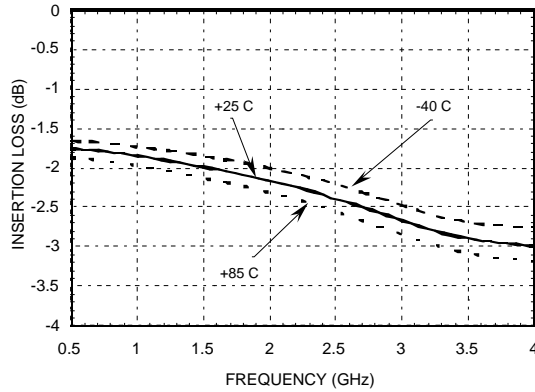

Return Loss RF1, RF2
(Only Major States are Shown)

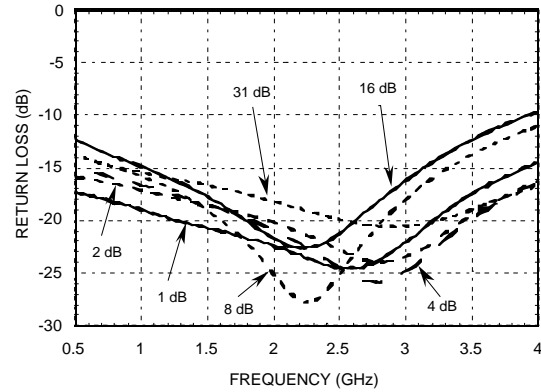

Normalized Attenuation
(Only Major States are Shown)

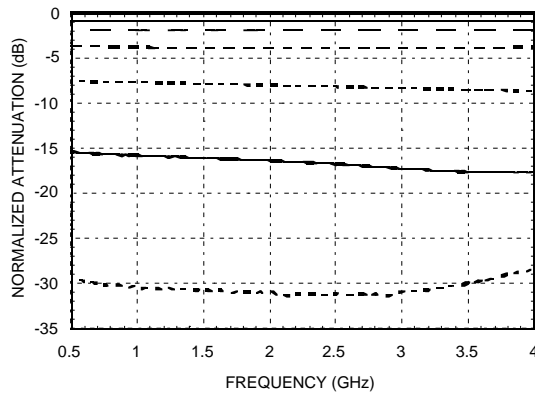

Absolute Bit Error vs. Attenuation State

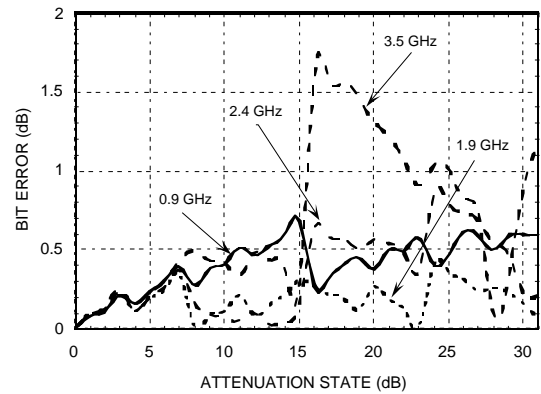

Absolute Bit Error vs. Frequency
(Only Major States are Shown)

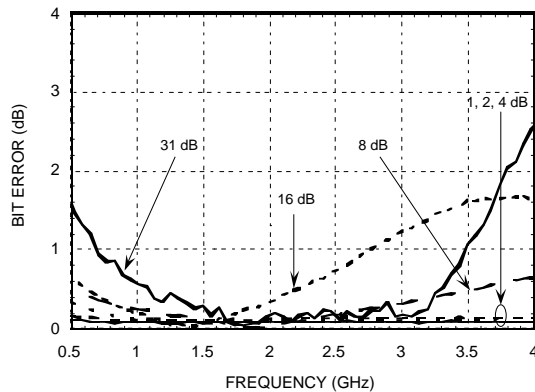

Relative Phase vs. Frequency
(Only Major States are Shown)

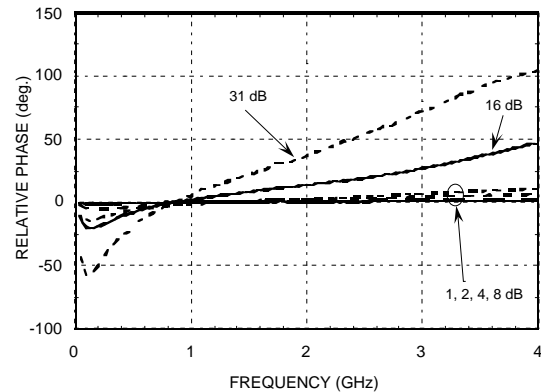

Note: All Data Typical Over Voltage (+3V to +5V) & Temperature (-40 to +85 deg. C.).

For price, delivery, and to place orders, please contact Hittite Microwave Corporation:
12 Elizabeth Drive, Chelmsford, MA 01824 Phone: 978-250-3343 Fax: 978-250-3373
Order Online at www.hittite.com

1 dB LSB GaAs MMIC 5-BIT DIGITAL ATTENUATOR, 0.7 - 3.7 GHz

Truth Table

Control Voltage Input					Attenuation Setting RF1 - RF2
V1 16 dB	V2 8 dB	V3 4 dB	V4 2 dB	V5 1 dB	
High	High	High	High	High	Reference I.L.
High	High	High	High	Low	1 dB
High	High	High	Low	High	2 dB
High	High	Low	High	High	4 dB
High	Low	High	High	High	8 dB
Low	High	High	High	High	16 dB
Low	Low	Low	Low	Low	31 dB Max. Atten.

Any combination of the above states will provide an attenuation approximately equal to the sum of the bits selected.

Control Voltages

State	Bias Condition
Low	0 to +0.2 V @ 20 uA Max
High	Vdd ± 0.2V @ 100 uA Max

Note: Vdd = +3V to 5V ± 0.2V

Application Circuit

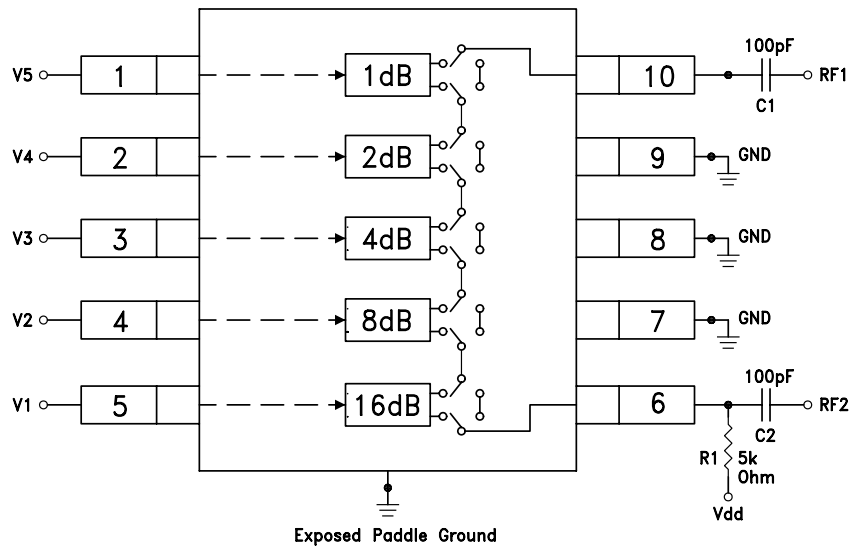

DC blocking capacitors C1 & C2 are required on RF1 & RF2. Choose C1 = C2 = 100 ~ 300 pF to allow lowest customer specific frequency to pass with minimal loss. R1 = 5K Ohm is required to supply voltage to the circuit through either PIN 6 or PIN 10.

1 dB LSB GaAs MMIC 5-BIT DIGITAL ATTENUATOR, 0.7 - 3.7 GHz

Absolute Maximum Ratings

Control Voltage (V1 - V5)	Vdd + 0.5 Vdc
Bias Voltage (Vdd)	+8.0 Vdc
Storage Temperature	-65 to +150 °C
Operating Temperature	-40 to +85 °C
RF Input Power (0.7 - 3.7 GHz)	+26 dBm

Outline Drawing

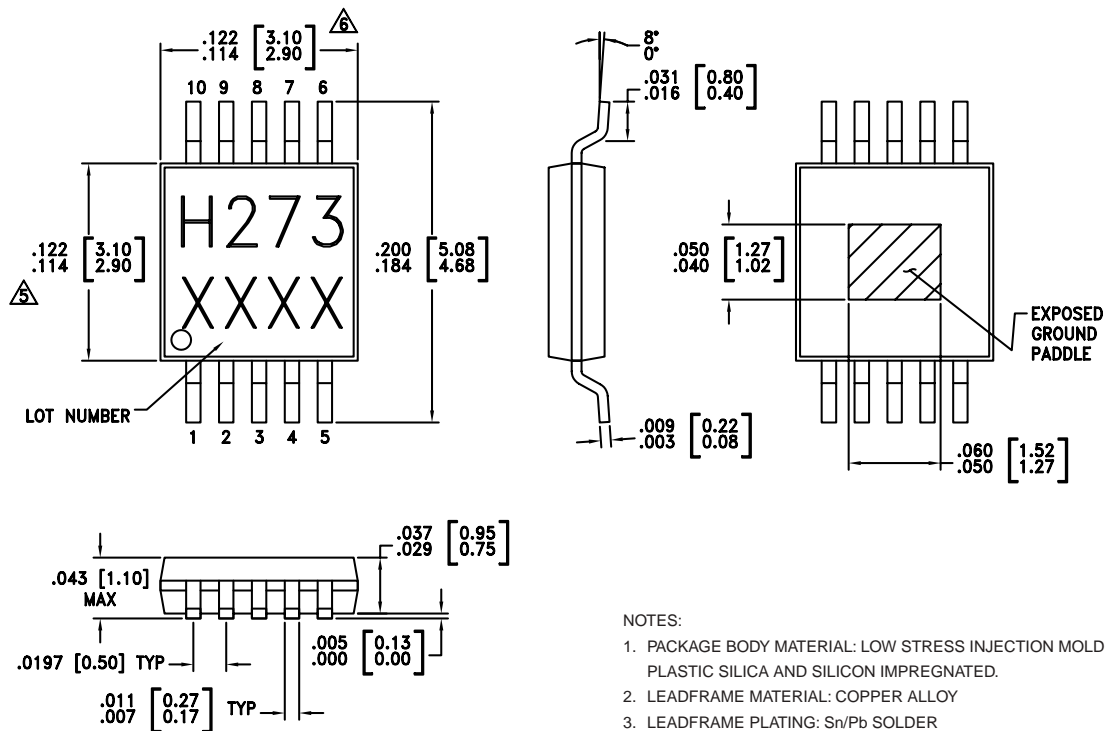

NOTES:

1. PACKAGE BODY MATERIAL: LOW STRESS INJECTION MOLDED PLASTIC SILICA AND SILICON IMPREGNATED.
2. LEADFRAME MATERIAL: COPPER ALLOY
3. LEADFRAME PLATING: Sn/Pb SOLDER
4. DIMENSIONS ARE IN INCHES [MILLIMETERS].
5. DIMENSION DOES NOT INCLUDE MOLDFLASH OF 0.15mm PER SIDE.
6. DIMENSION DOES NOT INCLUDE MOLDFLASH OF 0.25mm PER SIDE.
7. ALL GROUND LEADS AND GROUND PADDLE MUST BE SOLDERED TO PCB RF GROUND.

1 dB LSB GaAs MMIC 5-BIT DIGITAL ATTENUATOR, 0.7 - 3.7 GHz

Evaluation Circuit Board

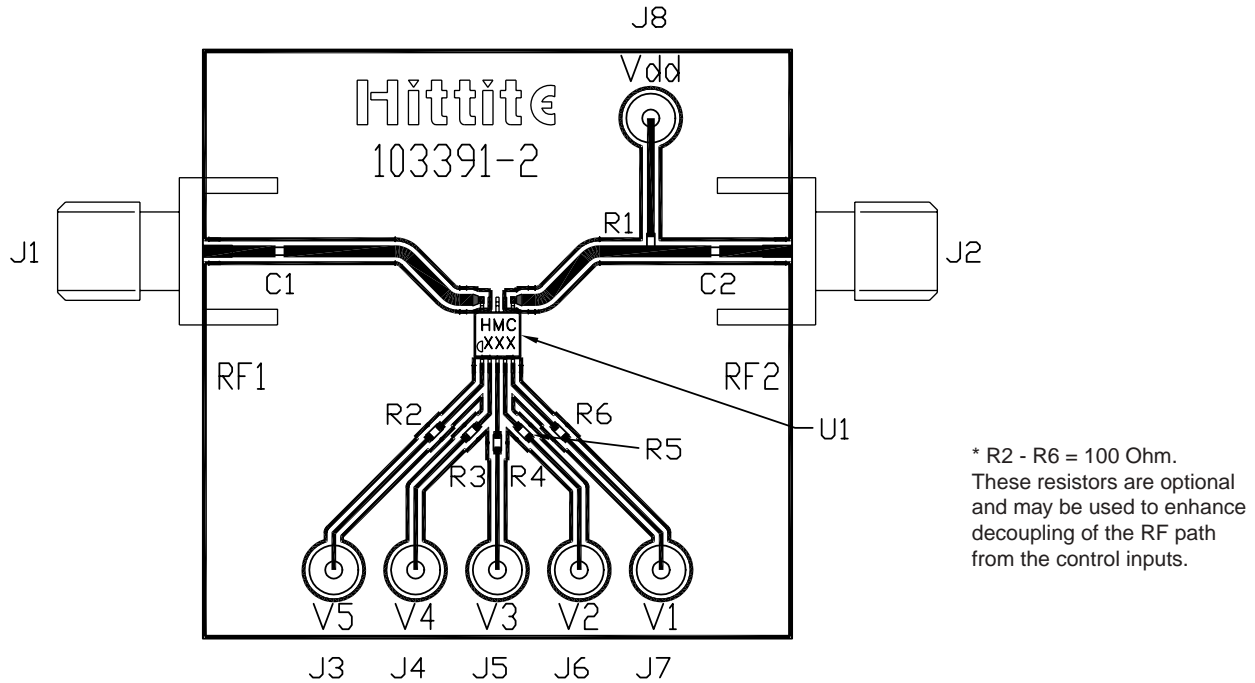

The circuit board used in the final application should use RF circuit design techniques. Signal lines should have 50 ohm impedance while the package ground leads and exposed ground paddle should be connected directly to the ground plane similar to that shown below. A sufficient number of VIA holes should be used to connect the top and bottom ground planes. The evaluation circuit board as shown is available from Hittite Microwave Corporation upon request.

List of Material

Item	Description
J1 - J2	PC Mount SMA Connector
J3 - J6	DC Pin
R1	5k Ohm Resistor, 0402 Chip
R2, R3, R4	100 Ohm Resistor, 0402 Chip
C1, C2	0402 Chip Capacitor, Select for Lowest Frequency of Operation
U1	HMC273MS10G Digital Attenuator
PCB*	103391 Evaluation PCB 1.5" x 1.5"

*Circuit Board Material: Rogers 4350

1 dB LSB GaAs MMIC 5-BIT DIGITAL ATTENUATOR, 0.7 - 3.7 GHz

Notes: