

# 2.5mm Pitch Connector for Discrete Wire Connection

HNC Series

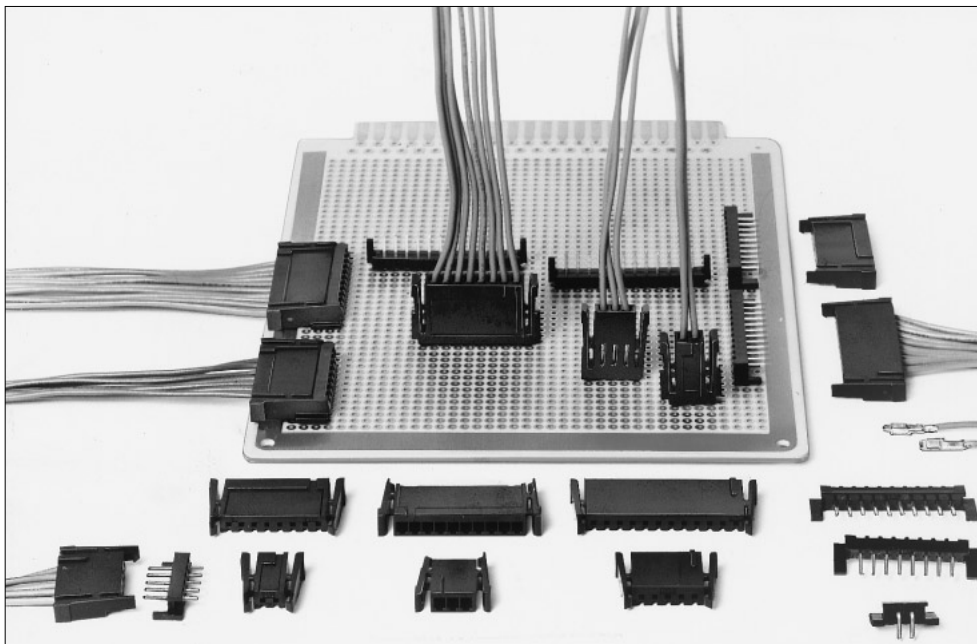

## ■ Features

### 1. Full Lock Mechanism

The connector is equipped with the full lock mechanism so as not to be removed, unless locks are reset on both sides. This mechanism is activated effectively to prevent cable hooking or mis-insertion.

### 2. Thin Type Connector

Mounting height when the connector is used at the right angle : **4.5mm**

### 3. Mechanism to Prevent Mis-insertion

This thin type connector is equipped with the mechanism to prevent mis-insertion.

### 4. Tin Plating and Gold Plating Variation

Two kinds of tin plating and gold plating types are available, and can be chosen according to application. The tin plating is also set to a light operating touch.

## ■ Applications

Various business equipment, financial terminals

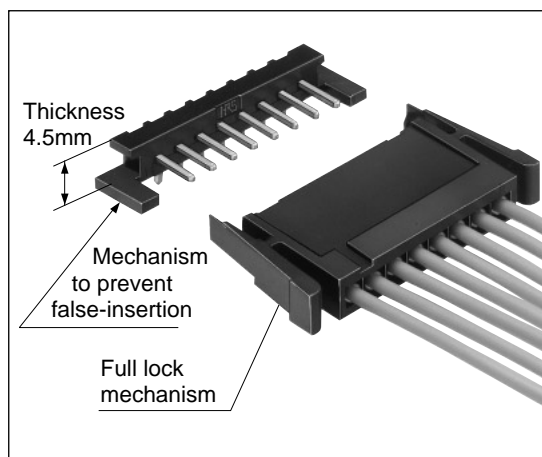

## ■Product Specifications

Rating	Current rating (Note1)	AWG 22 : 3A AWG 24 : 3A AWG 26 : 2A AWG 28 : 1A AWG 30 : 0.5A	Operating Temperature Range Operating Moisture Range	-25 to +85°C (Note2) 40 to 80%
	Voltage rating	250V AC	Storage Temperature Range Storage Moisture Range	-10 to +60°C (Note3) 40 to 70% (Note3)

Item	Specification	Condition
1. Insulation Resistance	1000M ohms min.	500V DC
2. Withstanding voltage	No flashover or insulation breakdown.	1000V AC/1 minute
3. Contact Resistance	30m ohms Max	1A
4. Insertor/Extraction Force	0.4N (40gf) min., 4.4N (450gf) max.	Measure at the square steel pin of 0.635±0.002mm
5. Vibration	No electrical discontinuity of 1μs or more	Frequency: 10 to 55 Hz, single amplitude of 0.75 mm, 2 hours in each of the 3 directions.
6. Humidity (Steady state)	Contact resistance: 10m ohms max. Insulation resistance: 1000M ohms min.	96 hours at temperature of 40°C and humidity of 90% to 95%
7. Temperature Cycle	Contact resistance: 10m ohms max. Insulation resistance: 1000M ohms min.	(-25°C: 30 minutes → 5 to 35°C: 10 minutes 85°C: 30 minutes → 5 to 35°C: 10 minutes) 5 cycles
8. Durability (Mating/un-mating)	Contact resistance: 20m ohms max.	Tin plating : 30 cycles Gold plating : 50 cycles
9. Resistance to Soldering heat	No deformation of components affecting performance.	Flow: 250°C for 5 seconds Manual soldering: 300°C for 2 seconds

Note 1: The rated current will be changed according to cable sizes for use. The header rating only is 3A.

Note 2: Includes temperature rise caused by current flow.

Note 3: The term "storage" refers to products stored for long period of time prior to mounting and use. Operating Temperature Range and Humidity range covers non conducting condition of installed connectors in storage, shipment or during transportation.

## ■Material

Product	Part	Material	Finish	Remarks
Crimping Socket	Insulator	Polyamide	Black	UL94V-0
Contact	Contact	Phosphor Copper	Tin plated or gold plated	—
Pin Header	Insulator	Polyamide	Black	UL94V-0
	Contact	Brass	Tin plated or gold plated	—

## ■Ordering Information

### ●Crimping Plug

HNC   2 - 2.5   P - \*   DSL  
 ①   ②   ③   ④   ⑤   ⑥

① Series Name : HNC	⑤ Number of Contacts : 2 to 16, 18, 20
② Series No. : 2, 1	⑥ Contact Type None : Crimping socket DS : Straight DSL : Right angle
③ Contact Pitch : 2.5mm	
④ Connector Type S : Socket P : Pin Header	

### ●Contact

HNC2 - 2.5S - C - A  
 ①   ②   ③

① Type: 2.5mm pitch socket	③ Applicable cable size A : AWG22 to 26 B : AWG26 to 30
② Packaging Type C : Reel PC : Bag	

# ■Crimping Socket

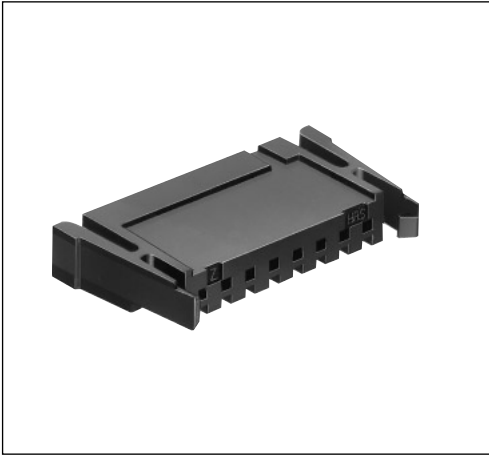

[Figure 1]

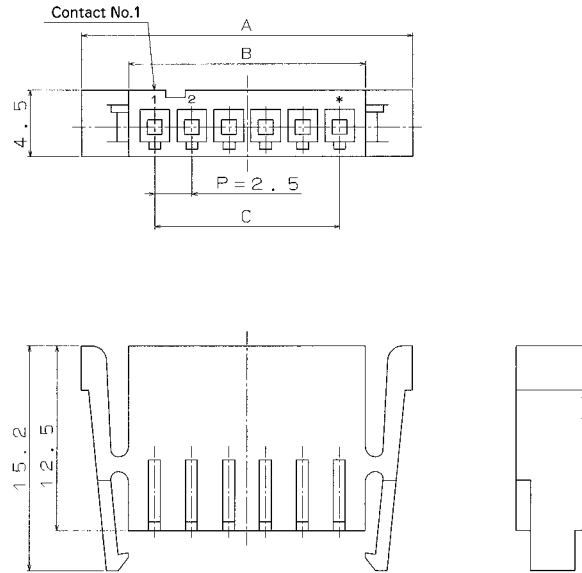

[Figure 2]

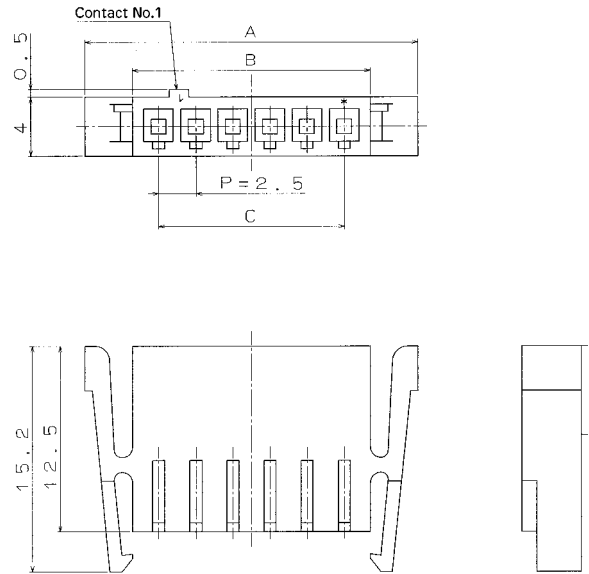

Unit: mm

Part Number	CL No.	Number of Contacts	A	B	C	Dimensions
HNC2-2.5S- 2(**)	218-0011-1-**	2	12.4	6	2.5	Figure 1
HNC2-2.5S- 3(**)	218-0022-8-**	3	14.9	8.5	5	
HNC2-2.5S- 4(**)	218-0039-0-**	4	17.4	11	7.5	
HNC2-2.5S- 5(**)	218-0027-1-**	5	19.9	13.5	10	
HNC2-2.5S- 6(**)	218-0042-5-**	6	22.4	16	12.5	
HNC2-2.5S- 7(**)	218-0030-6-**	7	24.9	18.5	15	
HNC2-2.5S- 8(**)	218-0014-0-**	8	27.4	21	17.5	
HNC2-2.5S-10(**)	218-0017-8-**	10	32.4	26	22.5	
HNC1-2.5S-12(**)	218-0008-7-**	12	37	31	27.5	Figure 2
HNC2-2.5S-15(**)	218-0045-3-**	15	44.9	38.5	35	Figure 1

[Specific No.] -\* \*, (\* \*)  
Blank :Bag packaging

Note1: Please order a quantity multiplied by 100 pcs. (Not per bag, but per pcs.)

Note2: The series name of 12 contacts connector is HNC1, and partially will be changed in the style.

# ■Straight Pin Header

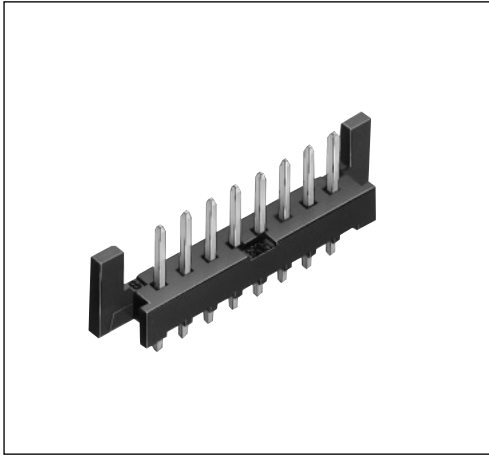

●Board Through-hole Diameter:  $\phi 1.1^{+0.1}$

[Figure 3]

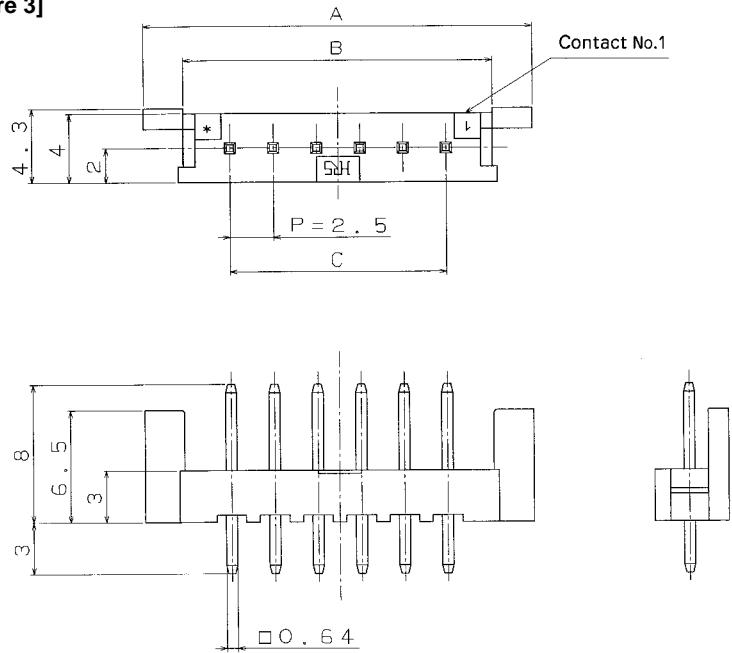

[Figure 4]

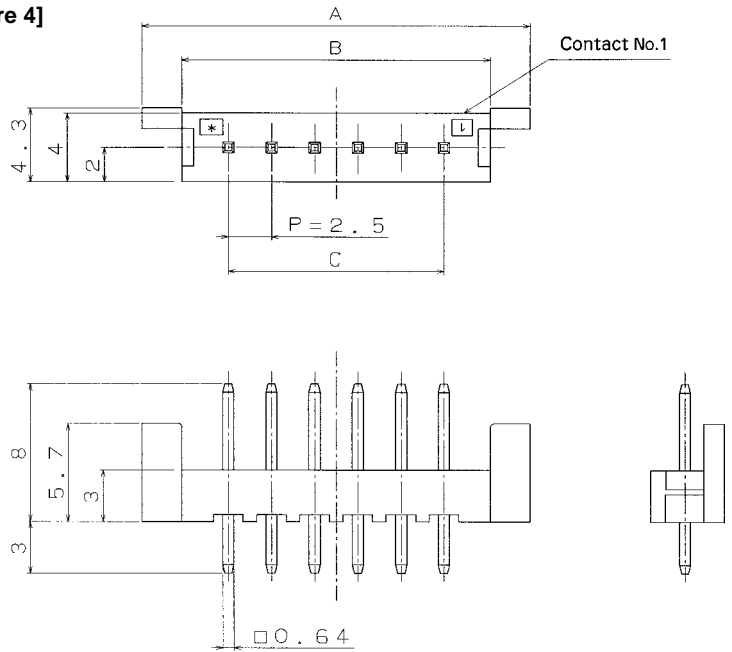

Unit: mm

Part Number	CL No.	Number of Contacts	A	B	C	Specific No.		Dimensions
						Tin plating	Gold plating	
HNC2-2.5P- 2DS(**)	218-0012-4-**	2	12.5	7.8	2.5	Blank	02	Figure 3
HNC2-2.5P- 3DS(**)	218-0023-0-**	3	15	10.4	5	Blank	02	
HNC2-2.5P- 4DS(**)	218-0040-0-**	4	17.5	12.9	7.5	Blank	01	
HNC2-2.5P- 5DS(**)	218-0028-4-**	5	20	15.4	10	Blank	02	
HNC2-2.5P- 6DS(**)	218-0043-8-**	6	22.5	17.9	12.5	Blank	01	
HNC2-2.5P- 7DS(**)	218-0031-9-**	7	25	20.4	15	Blank	02	
HNC2-2.5P- 8DS(**)	218-0015-2-**	8	27.5	22.8	17.5	Blank	02	
HNC2-2.5P-10DS(**)	218-0018-0-**	10	32.5	27.8	22.5	Blank	02	Figure 4
HNC1-2.5P-12DS(**)	218-0009-0-**	12	35.5	32.8	27.5	Blank	02	
HNC2-2.5P-15DS(**)	218-0046-6-**	15	45	40.4	35	Blank	01	Figure 3

Note1: Please order a quantity multiplied by 100 pcs. (Not per bag, but per piece)

Note2: The series name of the 12 contacts connector is HNC1 and the style will be partially changed.

# Right Angle Pin Header [Figure 5]

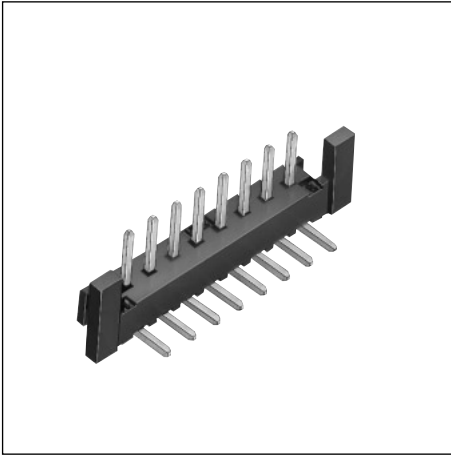

●Board Through-hole Diameter:  $\phi 1.1^{+0.1}$

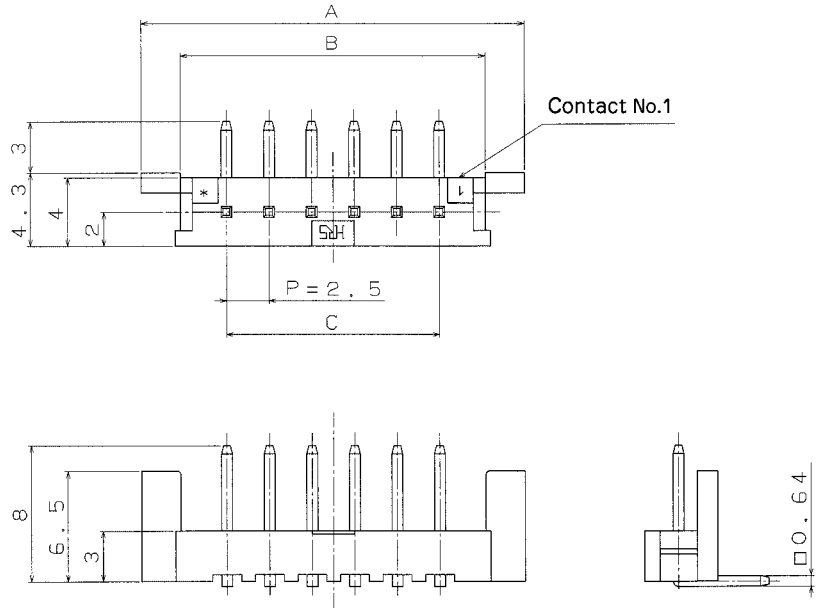

[Figure 6]

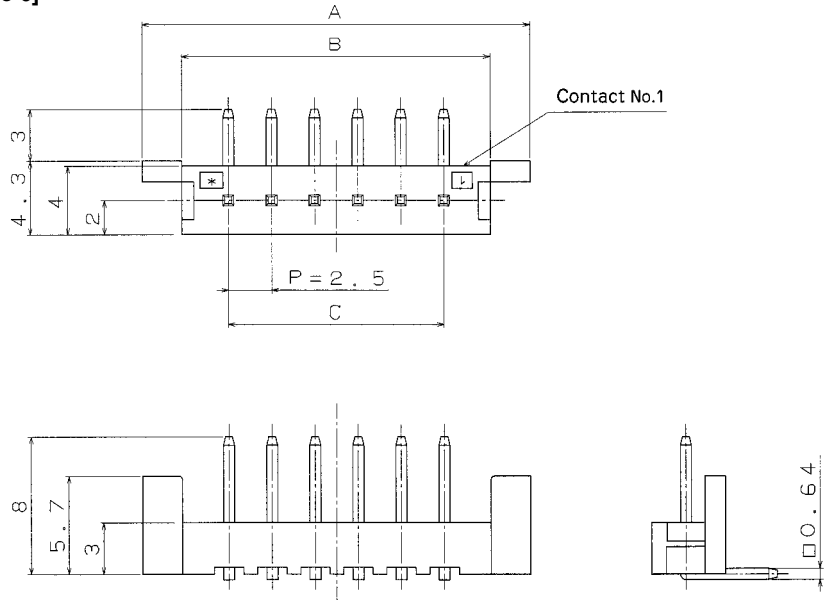

Unit: mm

Part Number	CL No.	Number of Contacts	A	B	C	Specific No.		Dimensions
						Tin plating	Gold plating	
HNC2-2.5P- 2DSL(**)	218-0013-7-**	2	12.5	7.8	2.5	Blank	02	Figure 5
HNC2-2.5P- 3DSL(**)	218-0024-3-**	3	15	10.4	5	Blank	02	
HNC2-2.5P- 4DSL(**)	218-0041-2-**	4	17.5	12.9	7.5	Blank	01	
HNC2-2.5P- 5DSL(**)	218-0029-7-**	5	20	15.4	10	Blank	02	
HNC2-2.5P- 6DSL(**)	218-0044-0-**	6	22.5	17.9	12.5	Blank	01	
HNC2-2.5P- 7DSL(**)	218-0032-1-**	7	25	20.4	15	Blank	02	
HNC2-2.5P- 8DSL(**)	218-0016-5-**	8	27.5	22.8	17.5	Blank	02	
HNC2-2.5P-10DSL(**)	218-0019-3-**	10	32.5	27.8	22.5	Blank	02	Figure 6
HNC1-2.5P-12DSL(**)	218-0010-9-**	12	35.5	32.8	27.5	Blank	02	
HNC2-2.5P-15DSL(**)	218-0047-9-**	15	45	40.4	35	Blank	01	Figure 5

Note1: Please order a quantity multiplied by 100 pcs. (Not per bag, but per piece)

Note2: The series name of the 12 contacts connector is HNC1 and the style will be partially changed.

## ■Crimping Contact for Socket

### ●Applicable Cable (Tin Plated Annealing Copper Wire)

### ●Recommended Cable

UL1061, UL1007

### ●Strip Length

2.8 to 3.3mm

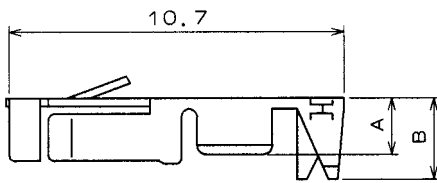

Conductor Size (Contact wire construction)	Jacket Diameter
AWG 22 (17pieces/0.16mm)	φ1.35 to φ1.7mm
AWG 24 (11pieces/0.16mm)	
AWG 26 ( 7pieces/0.16mm)	φ1.0 to φ1.35mm
AWG 28 ( 7pieces/0.127mm)	
AWG 30 ( 7pieces/0.1mm)	

Note: If other cables are used instead of the applicable cable, please contact Hirose sales department.

Unit: mm

Part Number	CL No.	Conductor Size	Jacket Diameter	A	B	Packaging Type	Quantity	Specific No.	
								Tin plating	Gold plating
HNC-2.5S-D-A(**)	218-0037-5-**-	AWG 22 to 26	φ1.35 to 1.7mm	1.8	2.6	Bag	100	Blank	02
HNC-2.5S-C-A(**)	218-0021-5-**-			1.8	2.6	Reel	10,000		
HNC-2.5S-D-B(**)	218-0038-8-**-	AWG 26 to 30	φ1.0 to 1.35mm	1.5	1.7	Bag	100		
HNC-2.5S-C-B(**)	218-0020-2-**-			1.5	1.7	Reel	10,000		

## ■Applicable Crimping Tool

Type	Part Number	CL No.	Applicable Contact
Applicator	AP105-HNC	901-4502-0	HNC-2.5S-C-A/HNC-2.5S-C-B
Press Main Unit	CM105	901-0005-4	_____
Manual Crimping Tool	TC-HNC-B	250-0005-7	HNC-2.5S-D-B
	TC-HNC-A	250-0006-0	HNC-2.5S-D-A
Extraction Tool	DF1-C-PO	550-0177-7	HNC-2.5S-C-A/HNC-2.5S-C-B

Note: If a trouble has occurred due to tools which are not designated by Hirose, Hirose won't guarantee any product.

## ■Application Pattern

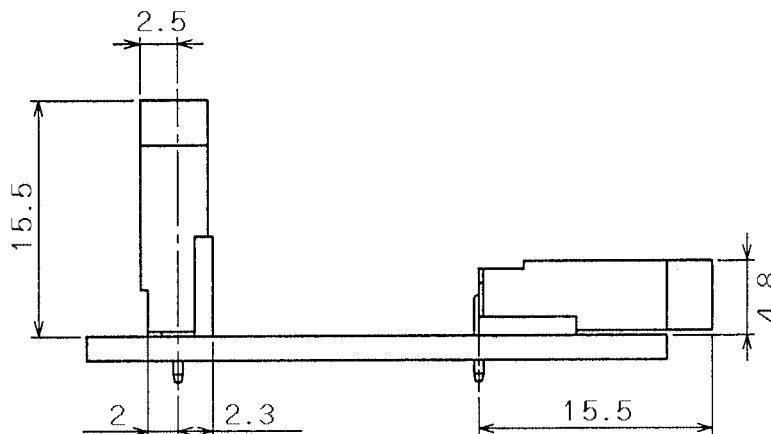

## ◆Precautions

1. Recommended Soldering Condition	Flow: 250°C for 3 seconds Manual soldering: 290°C for 2 seconds
2. Cleaning Condition	Refer to Nylon Connector Use Hand book.
3. Connection Condition	<p>Refer to Nylon Connector Use Hand book.</p> <p>●Extracting Crimping Contact</p> <p>To extract the crimping contact from the socket housing, observe the following extraction procedures.</p> <p>■Extraction Tool Tool Name: DF-C-PO(550-0177-7) can be used.</p> <p>(1) Extraction Method</p> <p>As shown below in the figure, slightly pull the cable in the state where the DF1 extraction tool tip or the 0.5 to 0.7mm board has been inserted in the lance fixed slot, the contact can be easily removed.</p> <p>Note: If the lance is pressed excessively, the contact body may be deformed, which could result in contact failure. Therefore, be careful not to press the lance excessively.</p> <div data-bbox="565 746 1458 985" data-label="Image"> </div> <p>(2) How to Adjust the Lance (Raise)</p> <p>To re-insert the terminal which is removed from the socket housing, use a sharp edge blade to raise the lance as shown below in the illustration, and then insert the contact.</p> <p>Note: Lance regeneration is effective only once.</p> <div data-bbox="805 1221 1154 1357" data-label="Image"> </div>