



CMOS HS-1430 Series

Rev. J

Description

The **HS-1430 Series** of quartz crystal oscillators provide enable/disable 3-state CMOS compatible signals for bus connected systems. Supplying Pin 1 of the HS-1430 units with a logic "1" or open enables its pin 8 output. In the disabled mode, pin 8 presents a high impedance to the load.

Features

- Wide frequency range— 68.0MHz to 145.0MHz
- User specified tolerance available
- Will withstand vapor phase temperatures of 253°C for 4 minutes maximum
- Space-saving alternative to discrete component oscillators
- High shock resistance, to 3000g
- All metal, resistance weld, hermetically sealed package

- Low Jitter
- High Q Crystal actively tuned oscillator circuit
- Power supply decoupling internal
- No internal PLL avoids cascading PLL problems
- Low power consumption
- Gold plated leads - Solder dipped leads available upon request

Electrical Connection

Pin	Connection
1	Enable Input
7	Grd & Case
8	Output
14	V _{DD}

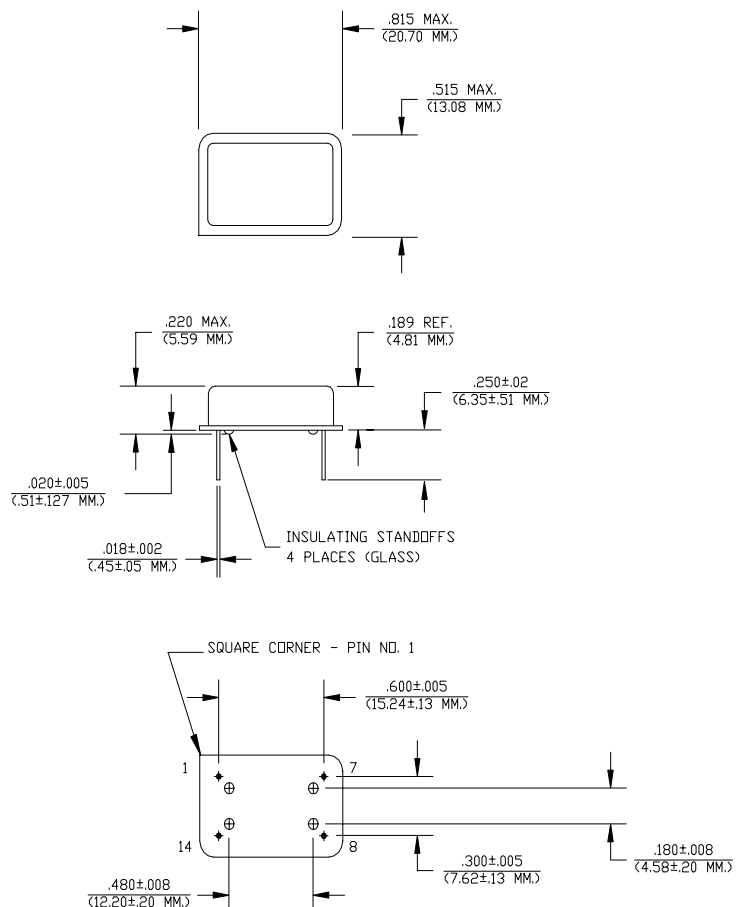

Dimensions are in inches and (MM)

HS-1430 Series Continued
CMOS

Rev. J

Operating Conditions and Output Characteristics

Electrical Characteristics

Parameter	Symbol	Conditions	Min	Typical	Max
Frequency	-----	-----	68.0MHz	-----	145.0MHz
Duty Cycle	-----	@ $V_{DD}/2$	40/60%	-----	60/40%
Logic 0	V_{OL}	@ 600 μ A	-----	-----	0.2V
Logic 1	V_{OH}	@ 600 μ A	$V_{DD}-0.2V$	-----	-----
Rise & Fall Time	tr,tf	10-90%	-----	1 ns	3 ns
TPz	-----	-----	-----	-----	5 ms
Jitter, RMS ⁽²⁾	-----	-----	-----	-----	5 psec
Frequency Stability ⁽¹⁾	dF/F	Overall conditions including voltage, calibration, temp., 10 yr aging, shock, vibration	-100ppm	-----	+100ppm

General Characteristics

Parameter	Symbol	Conditions	Min	Typical	Max
Supply Voltage	V_{DD}	-----	4.75V	5.0V	5.25V
Supply Current	I_{DD}	No Load	0.0 mA	-----	80mA
Output current	I_O	-----	0.0 mA	-----	± 16.0 mA
Operating temperature	T_A	-----	0°C	-----	70°C
Storage temperature	T_S	-----	-55°C	-----	125°C
Power Dissipation	P_D	-----	-----	-----	420 mW
Lead temperature	T_L	Soldering, 10 sec.	-----	-----	300°C
Load	-----	-----	-----	-----	15pf
Start-up time	t_s	-----	-----	2 ms	10 ms

Environmental and Mechanical Characteristics

Mechanical Shock Per MIL-STD-202, Method 213, Condition E
 Thermal Shock Per MIL-STD-833, Method 1011, Condition A
 Vibration 0.060" double amplitude 10 Hz to 55 Hz, 35g's 55Hz to 2000 Hz
 Soldering Condition 300°C for 10 seconds
 Hermetic Seal Leak rate less than 1×10^{-8} atm.cc/sec of helium

Footnotes:

- Standard frequency stability ($\pm 20, \pm 25, \pm 50$ ppm & others available)
- Jitter performance is frequency dependent. Please contact factory for full characterization.

Test Load:

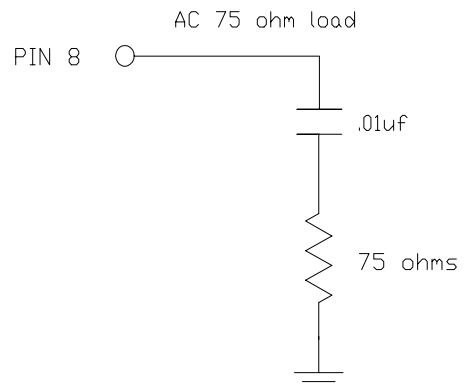

Creating a Part Number

HS - A143X - FREQ

Package Code

HS Leaded 4 pin (14 pin)
 SM Leaded 4 pin (14 pin) SMD
 Gull Wing

Input Voltage

Code Specification
 A 3.3V
 5V

Tolerance/Performance

0 ± 100 ppm 0-70°C
 1 ± 50 ppm 0-70°C
 7 ± 25 ppm 0-70°C
 9 Customer Specific
 A ± 20 ppm 0-70°C
 B ± 50 ppm -40 to +85°C
 C ± 100 ppm -40 to +85°C