

Stripline Mounting Non-reflective Terminations

HT Series

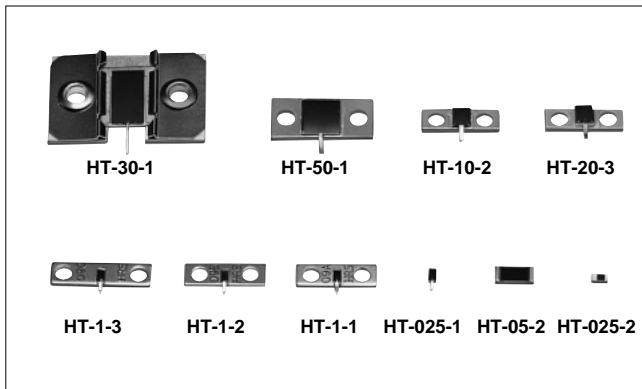

■Features

1.High Performance

These super wide bandwidth/ultra high matching non-reflective termination use Hirose Electric original high frequency matching technology.

2.Equipped with Tabs

Termination are equipped with tabs to permit direct mounting to flat circuits.

3.Housing functions as a radiator to permit small size and high-density mounting.

■Product Specifications

Ratings	Rated frequency range (Note) Characteristic impedance Maximum Input Power (Note)	DC to 15.0 GHz 50 ohms 0.25 to 50 W	Operating temperature range Operating relative humidity	-10°C to +60°C 95% Max.
---------	--	---	--	----------------------------

NOTE: The frequency range and the maximum input power will differ depending on the products.

HT-025-1, HT-025-2, HT-05-2, HT-1-1, HT-1-2, HT-1-3, HT-10-2, HT-20-3, and HT-50-1

Item	Standard	Conditions
1.Vibration	No electrical discontinuity of 1 μ s or more No damage, cracks, or parts dislocation	Frequency of 10 to 2000 Hz, overall amplitude of 1.52 mm, acceleration of 98 m/s ² for 2 hours in each of 3 directions
2.Shock		Acceleration of 490 m/s ² , sine half-wave waveform, 3 cycles in each of the 3 axis
3.Temperature cycle	No damage, cracks, or parts dislocation	Temperature: -55°C → +5°C to +35°C → +85°C → +5°C to +35°C Time: 30 → 15 max. → 30 → 15 max. (Minutes) 200 cycles

●The test method conforms to MIL-STD-202.

HT-30-1

Item	Standard	Conditions
1.Vibration	No electrical discontinuity of 1 μ s or more No damage, cracks, or parts dislocation	Frequency of 10 to 2000 Hz, overall amplitude of 1.52 mm, acceleration of 98 m/s ² for 2 hours in each of 3 directions
2.Shock		Acceleration of 294 m/s ² , sine half-wave waveform, 3 cycles in each of the 3 axis
3.Temperature cycle	No damage, cracks, or parts dislocation	Temperature: -55°C → +5°C to +35°C → +120°C → +5°C to +35°C Time: 30 → 15 max. → 30 → 15 max. (Minutes) 200 cycles

●The test method conforms to MIL-STD-202.

■Materials

HT-025-1, HT-025-2, and HT-05-2

Part	Material	Finish
Tabs	Copper	Solder plating
Resistor	Metal film	——

HT-30-1

Part	Material	Finish
Plate	Aluminum	Conductive alumite
Retaining plate	Phosphor bronze	Nickel plating
Tabs	Copper	Tin plating
Resistor	Metal film	——

HT-1-1, HT-1-2, and HT-1-3

Part	Material	Finish
Plate	Aluminum	Nickel plating
Tabs	Copper	Solder plating
Resistor	Metal film	——

HT-10-2, HT-20-3, and HT-50-1

Part	Material	Finish
Plate	Copper	Nickel plating
Tabs	Copper	Silver plating
Resistor	Metal film	——

Ordering Information

HT - **025** - **1**
① ② ③

① Series Name: HT Series	③ Suffix
② Power (Example)0.25:0.25W 1:1W	

Specifications

Part Number	Frequency Range (GHz)	V.S.W.R. (MAX)	Impedance (Ohms)	Power (W)	Heat Sink Temperature at Maximum Load (°C Max)	Heat Resistance (°C/W)	Weight (g)
HT-025-1	DC-8	1.30	50	1/4	+65	50	0.1
HT-025-2	DC-8	1.30	50	1/4	+65	50	0.1
HT-05-2	DC-1	1.20	50	1/2	+65	150	0.3
HT-1-1	DC-8	1.30	50	1	+65	50	0.3
HT-1-2							
HT-1-3							
HT-10-2	DC-6	1.20	50	10	+65	9	0.3
△ HT-20-3	DC-15	1.15(DC-4GHz)	50	20	+65	3.8	0.6
		1.25(4-8GHz)					
		1.45(8-12.4GHz)					
		1.55(12.4-15GHz)					
HT-30-1	DC-1	1.20	50	30	+65	3	3
△ HT-50-1	DC-5	1.25	50	50	+65	1.6	1.5

△ CAUTION: Beryllia is used in this product. Please follow associated laws when disposing.

Typical Data

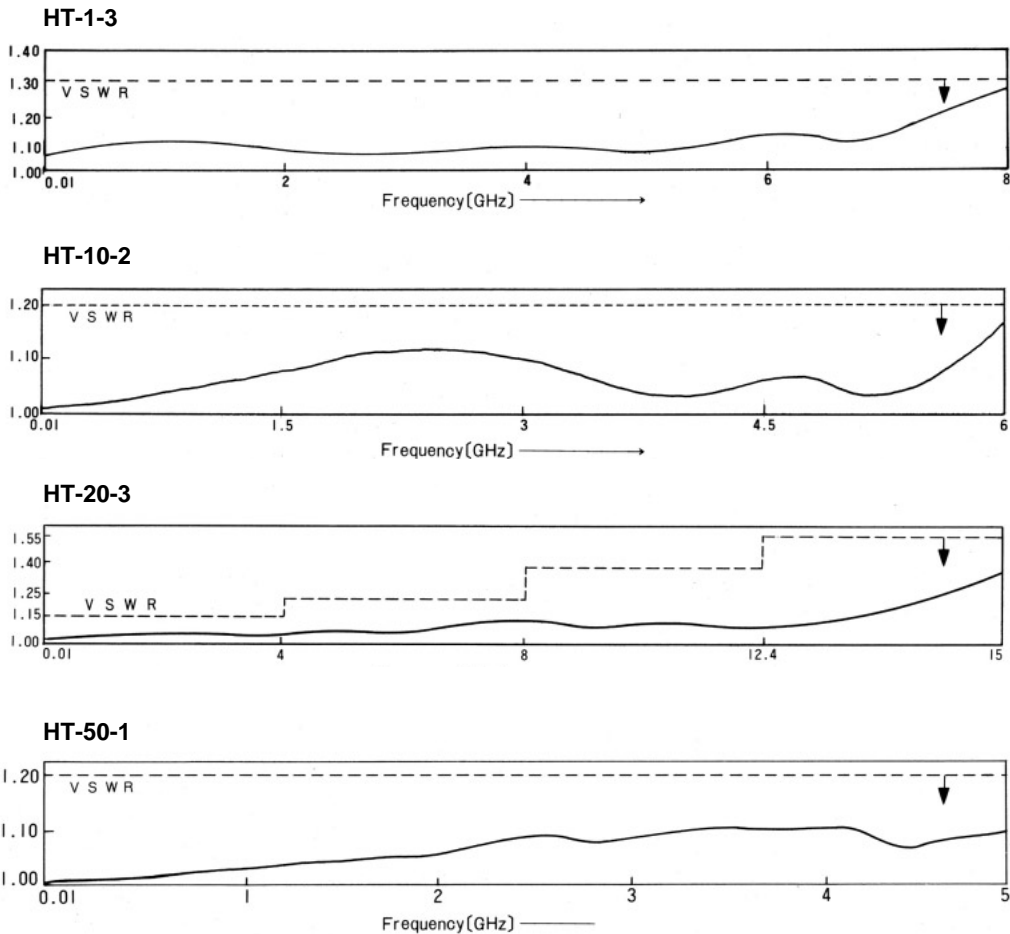

External Dimensions

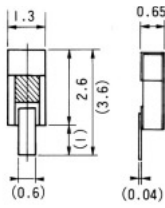

HT-025-1

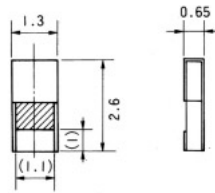

HT-025-2

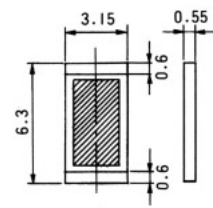

HT-05-2

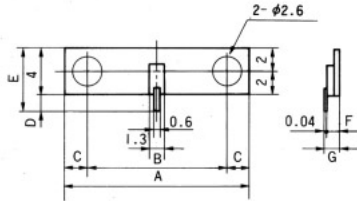

PCB Mounting Pattern

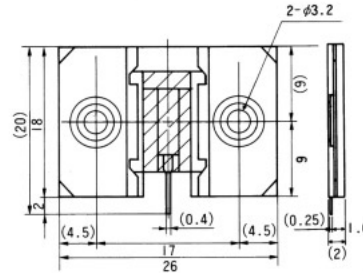

PCB Mounting Pattern

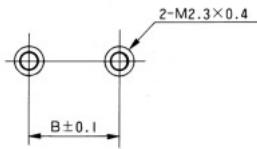

HT-1-1 · HT-1-2 · HT-1-3

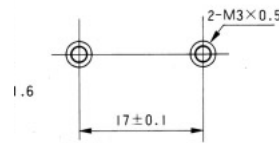

HT-30-1

Part Number	A	B	C	D	E	F	G
HT-1-1	13	8	2.5	1.4	5.4	1.45	1.49
HT-1-2	13	8	2.5	1.4	5.4	1.15	1.19
HT-1-3	16	12	2	1.4	5.4	1.45	1.49

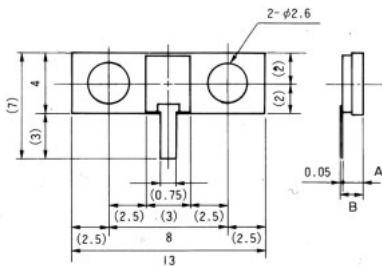

PCB Mounting Pattern

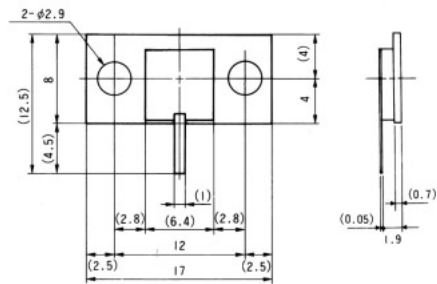

PCB Mounting Pattern

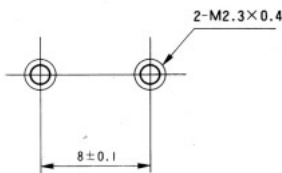

HT-10-2
HT-20-3

Part Number	A	B
HT-10-2	1.65	1.7
HT-20-3	2	2.05

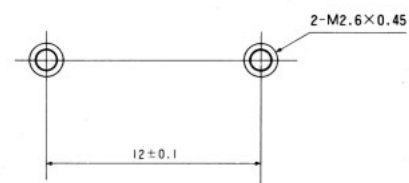

HT-50-1

■ Mounting Method

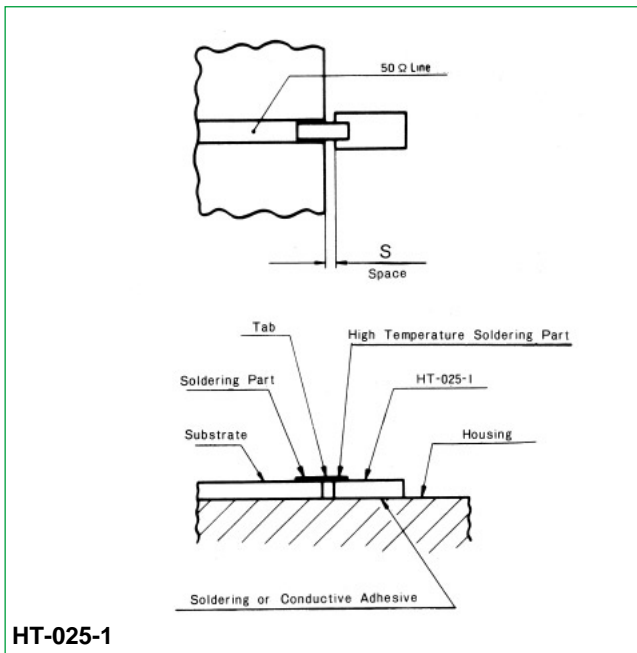

- Do not leave a space between the terminator and the microstrip board.
- Make the terminator tab height from the housing and the thickness of the microstrip board the same amount.
- Note: The HT-025-1 type is attached with high temperature solder (having a melting point of 280°C). The soldering temperature to the microstrip board must be less than this.

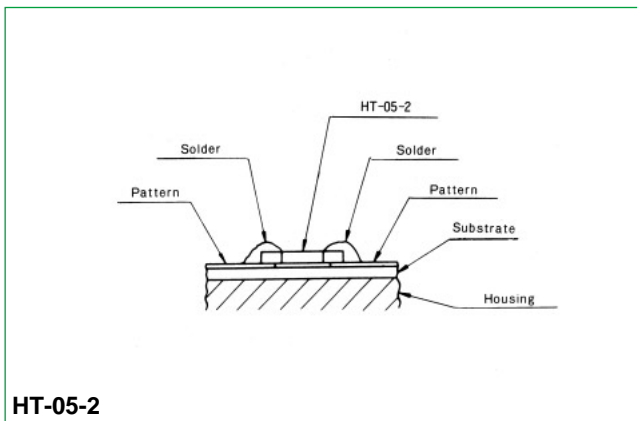

- Mounting is performed by soldering over the microstrip line pattern.
- The mounting should be completed by soldering within 5 seconds using Sn-Pb type eutectic solder containing 2 to 5% Ag with a soldering iron adjusted to about 260°C.
- The resoldering of an item that has already been soldered once and then removed is not effective since solder cracks will develop at the electrode portion.

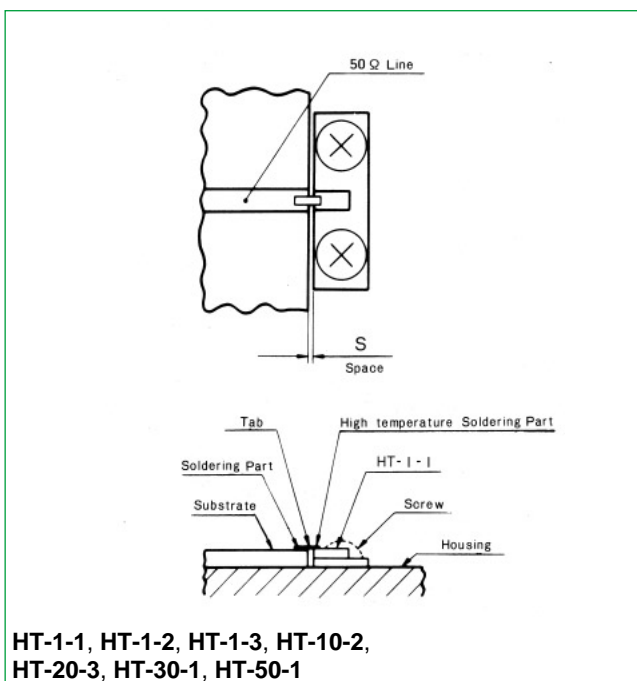

- Do not leave a space between the terminator and the microstrip board.
- Do not leave a space between the the microstrip board.
- Note: The HT-1-1, HT-1-2, HT-1-3, HT-10-2, HT-20-3, and HT-50-1 tabs are attached with high temperature solder (having a melting point of 280°C). The soldering temperature to the microstrip board must be less than this.

Note: Although the high frequency characteristics will deteriorate somewhat, please attach with some slack in the tabs in order to raise the thermal reliability.

Terminations for the Division Part of a Wilkinson Divider (100 ohms Type)

HT Series

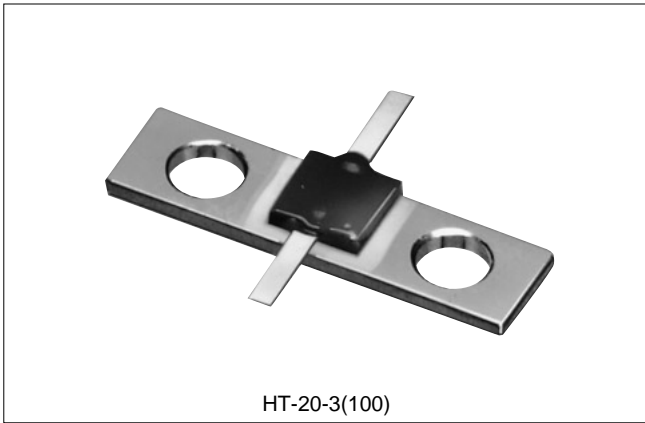

HT-20-3(100)

■ Features

1. High Performance

These wide bandwidth/ultra high matching non-reflective termination use Hirose Electric original high frequency matching technology.

2. Equipped with Tabs

Termination are equipped with tabs to permit direct mounting to Wilkinson type flat circuits.

3. High Power and Small Size

Beryllia is used for the material of the resistance element to enable the termination to be of small size and used with high power.

■ Product Specifications

Ratings	Rated frequency range	DC to 8.0 GHz	Heat sink temperature at maximum output	+65°C Max.
	Characteristic impedance	100 ohms	Operating temperature range	10°C to +65°C
	Maximum Input Power	20W	Operating relative humidity	95% Max.
	Resistance value	100±2 ohms	Weight	0.4 g

Item	Standard	Conditions
1. Vibration	No electrical discontinuity of 1 μs or more No damage, cracks, or parts dislocation	Frequency of 10 to 2000 Hz, overall amplitude of 1.52 mm, acceleration of 98 m/s ² for 2 hours in each of 3 directions
2. Shock		Acceleration of 490 m/s ² , sine half-wave waveform, 3 cycles in each of the 3 axis
3. Temperature cycle	No damage, cracks, or parts dislocation	Temperature: -55°C → +5°C to +35°C → +120°C → +5°C to +35°C Time: 30 → 15 max. → 30 → 15 max. (Minutes) 200 cycles

■ Material

Part	Material	Finish
Plate	Copper	Nickel plating
Tabs	Copper	Silver plating
Resistor	Metal film	—

■ External Dimensions

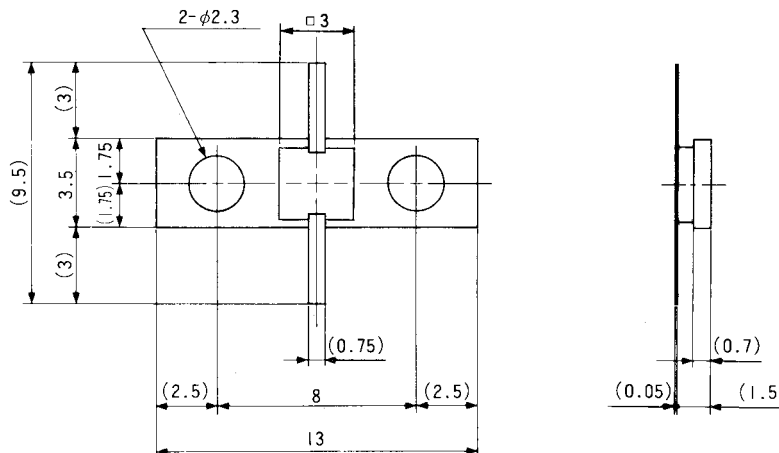

△ CAUTION: Beryllia is used in this product. Please follow associated laws when disposing.