

High Voltage Isolated MOSFET Driver

Ordering Information

Input to Output Isolation Voltage	Package Option
	8-Pin Narrow Body SOIC
±400V	HT0740LG

Features

- ±400V input to output isolation
- No external voltage supply required
- Low input logic current, 200µA max
- Floating isolated output
- 5.0V logic compatible

Applications

- Telecommunications
- Modems
- Solid state relays
- High side switches
- High end audio switches
- Avionics
- ATE

Absolute Maximum Ratings¹

Input to Output Isolation Voltage, V_{ISO}	±400V
Logic Input Voltage, V_{IN}	-0.5 to +7.0V
Operating Temperature	-40°C to +85°C
Storage Temperature	-55°C to +150°C
Soldering Temperature ²	300°C

Note:

1. All voltages are referenced to ground.
2. Distance of 1.6mm from case for 10 seconds.

General Description

The Supertex HT07 is a single channel high voltage low input current isolated driver utilizing Supertex's proprietary HVCMOS[®] technology. It is designed to drive discrete MOSFETs configured as high side switches up to 400V. The HT07 generates an independent DC isolated voltage across the pair of outputs when the logic input is at a logic high. The HT07 does not require any external power supplies. The internal supply voltage is supplied from the logic input when it is in the high state.

Pin Configuration

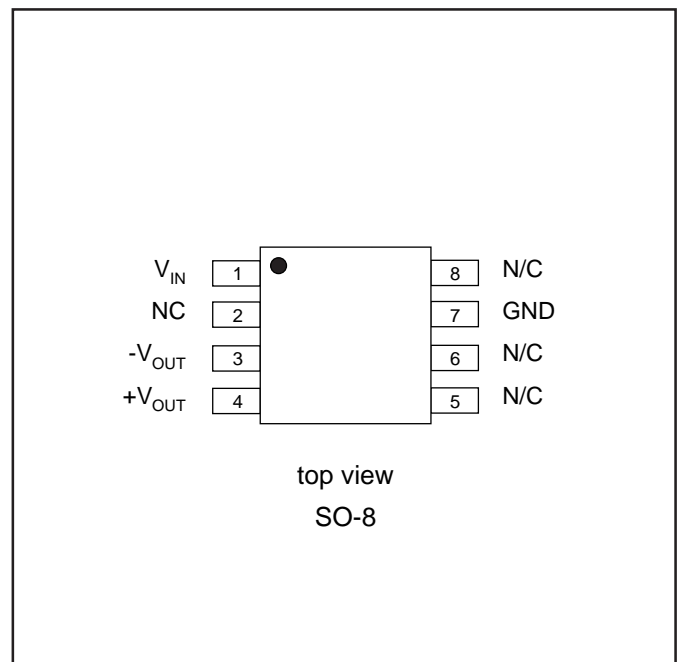

Electrical Characteristics

(over recommended operating conditions, $T_A = 25^\circ\text{C}$ unless otherwise specified)

DC Characteristics

Symbol	Parameter	Min	Typ	Max	Unit	Conditions
I_H	Logic input current high			200	μA	$V_{IN} = 5.0\text{V}$
I_{LQ}	Logic input current low (quiescent)			10	μA	$V_{IN} = 0.5\text{V}$
V_{OUT}	Output voltage across output terminals	5.0			V	$V_{IN} = 3.15\text{V}$, No load
		9.0			V	$V_{IN} = 4.5\text{V}$, No load
V_{IN}	Input voltage for zero output			0.8	V	No load
V_{ISO}	Input to output isolation voltage	± 400			V	

AC Characteristics

Symbol	Parameter	Min	Typ	Max	Unit	Conditions
$t_{d(ON)}$	Turn on delay time			50	μs	See timing diagram and test circuit $C_L = 600\text{pF}$
t_r	Rise time			650	μs	
$t_{d(OFF)}$	Turn off delay time			150	μs	
t_f	Fall time			3.0	ms	

Recommended Conditions

Symbol	Parameter	Min	Typ	Max	Unit	Conditions
V_{IH}	Logic input high voltage	3.15		5.5	V	
V_{IL}	Logic input low voltage	0		0.5	V	
T_A	Operating temperature	-40		+85	$^\circ\text{C}$	

Block Diagram

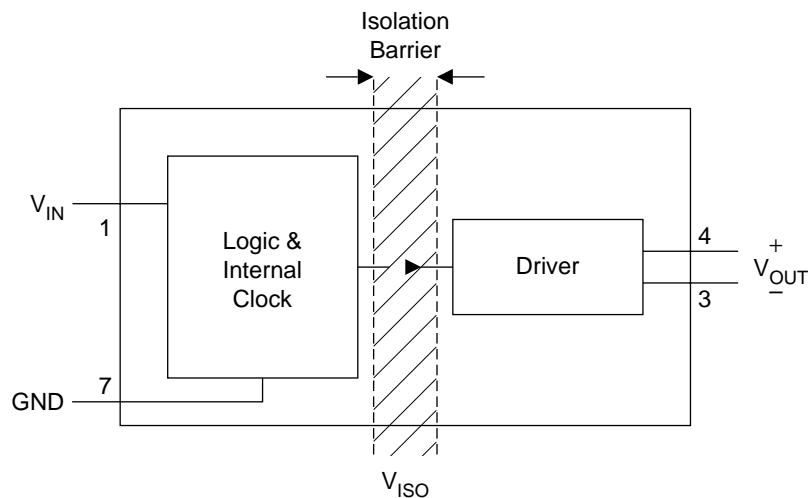

Timing Diagram

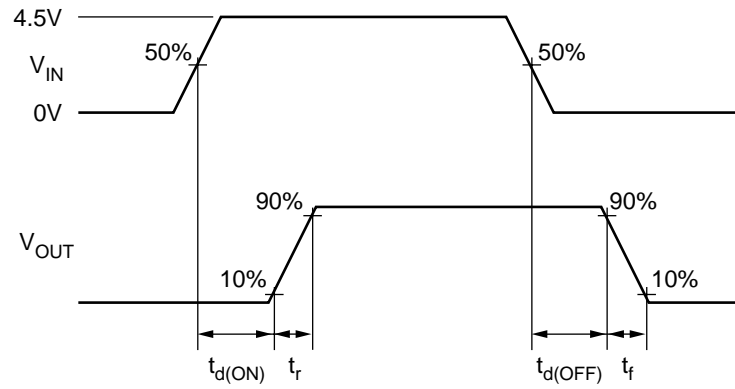

Test Circuit

