

Electronic Telephone Line Switch

Ordering Information

Breakdown Voltage	Switch Resistance	Package Option	
		Dial Pulse Pin DP/DP	SO-8
350V	18Ω	Active High	HT18LG
350V	18Ω	Active Low	HT19LG

Features

- 350V breakdown voltage
- 18Ω maximum switch resistance
- Current limiting protection
- Operates at 2.0V input

Applications

- Telephone handsets
- Modems
- Fax machines
- Answering machines
- Remote meter reading
- Phone interface products

Absolute Maximum Ratings

V_{TPG} , Input line voltage	+350V
V_{TP} , Output line voltage	+18V
DP/\overline{DP} continuous input voltage	+10V
Storage temperature	-65°C to +150°C
Junction temperature	+150°C
Soldering temperature*	+300°C
Power dissipation	0.8 Watt

Notes: All voltages are referenced to ground.

*Distance of 1.6mm from case for 10 seconds.

General Description

The Supertex HT18LG and HT19LG are electronic line switch circuits that replace the mechanical hook switch contact or a discrete hook switch in a telephone handset or modem. They switch the positive side of the telephone line using control inputs that are referenced to the negative side of the line. In the off state, they can withstand 350V on the positive input. In the on state their series resistances are 18Ω maximum. The devices provide current limiting determined by an external resistor. There are three control inputs. The HKS pin turns on the hook switch when connected to the TPG pin. This can be accomplished by using a mechanical switch which closes when the handset is physically off-hook. The LS pin allows a logic signal to turn on the hook switch. The dial pulse, Pin 6, is used to turn the hook switch off for pulse dialing. For the HT18, the dial pulse is active high (DP) whereas for the HT19, it is active low (\overline{DP}).

Pin Configuration

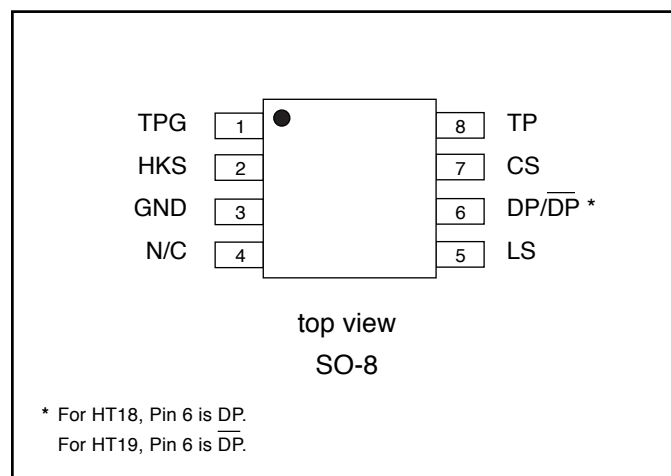

Note: See Package Outline section for dimensions.

Electrical Characteristics

(Over operating supply voltages unless otherwise specified, $T_A = 0^\circ\text{C}$ to $+50^\circ\text{C}$)

Symbol	Parameter	Min	Typ	Max	Unit	Conditions
V_{TPG}	High voltage positive supply			350	V	$I_{TPG} = 500\mu\text{A}$, HKS, LS, DP/DP = open circuit
I_{TPG}	Input leakage current			2.0	μA	$V_{TPG} = 100\text{V}$, HKS, LS, DP/DP = open circuit
				200		$V_{TPG} = 290\text{V}$, HKS, LS, DP/DP = open circuit
R_{SW}	TPG to TP switch resistance			18	Ω	$V_{TPG}=17\text{V}$, $I_{TPG}=180\text{mA}$, SW= On
				18		$V_{TPG}=3.0\text{V}$, $I_{TPG}=20\text{mA}$, SW= On
				30		$V_{TPG}=2.0\text{V}$, $I_{TPG}=5\text{mA}$, SW= On
$I_{TPG}-I_{TP}$	Bias current			50	μA	$V_{TPG} = 5.0\text{V}$, SW = On
				100		$V_{TPG} = 10\text{V}$, SW = On
I_{LIM}	I_{TPG} current limiting	188	250	313	mA	$R_{EXT} = 158\Omega \pm 1\%$
I_{HKS}	HKS input current			200	μA	$V_{HKS} = 40\text{V}$ to 70V
I_{LS} , I_{DP}	LS and DP logic input current			30	μA	$V_{LS} = 3.0\text{V}$, $V_{DP} = 3.0\text{V}$
$I_{\overline{DP}}$	DP logic input current			-30	μA	$V_{\overline{DP}} = 0\text{V}$
$V_{IL(HKS)}$	HKS input low	0		0.2	V	$V_{TPG} = 3.0\text{V}$ to 70V
$V_{IH(HKS)}$	HKS input high	2.0		V_{TPG}	V	$V_{TPG} = 3.0\text{V}$ to 70V
$V_{IL(LS)}$, $V_{IL(DP)}$	Input logic low for DP/ \overline{DP} and LS	0		0.2	V	$V_{TPG} = 3.0\text{V}$ to 70V
$V_{IH(LS)}$, $V_{IH(DP)}$	Input logic high for DP/ \overline{DP} and LS	1.5		10	V	$V_{TPG} = 3.0\text{V}$ to 70V
T_{ON}	Turn on time			1.0	ms	$V_{TPG} = 4.5\text{V}$
T_{OFF}	Turn off time			1.0	ms	$V_{TPG} = 4.5\text{V}$

Truth Table

HKS	LS	DP	\overline{DP}	Switch State
H	L or Z	L or Z	H or Z	ON
H	H	L or Z	H or Z	ON
L or Z	L or Z	L or Z	H or Z	OFF
L or Z	H	L or Z	H or Z	ON
X	X	H	L	OFF

Z = high impedance, open circuit

X = don't care

L = logic level low

H = logic level high

Block Diagram

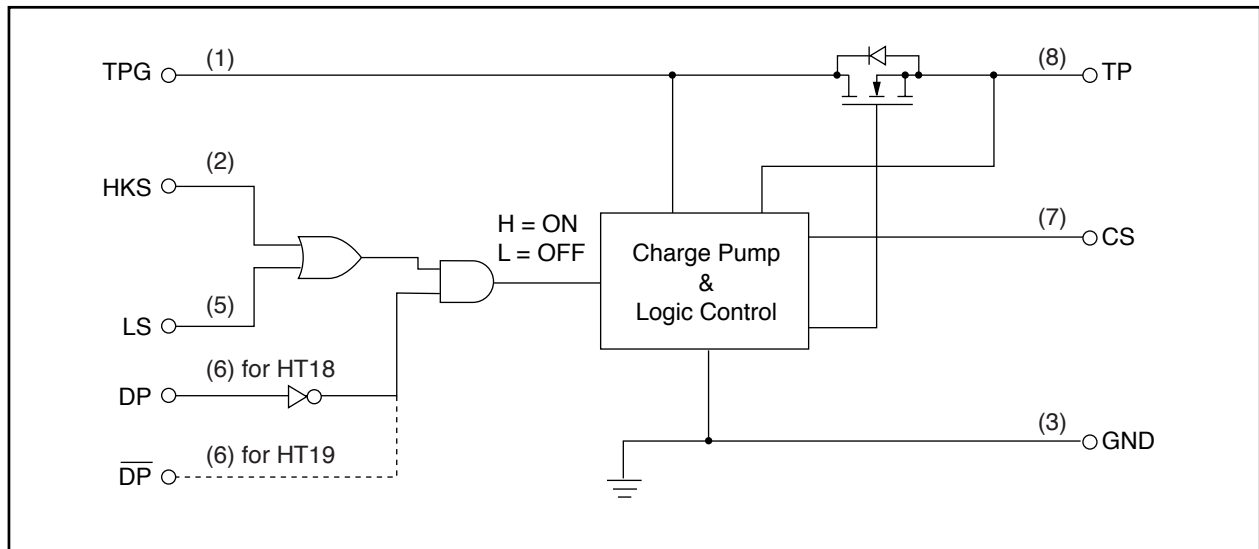

Pin Description

Pin #	Symbol	Description
1	TPG	Positive input side of a telephone line, typically Tip side.
2	HKS	Hookswitch input. Connect HKS to TPG to turn on the hook switch. Internally pulled low with a high value resistor.
3	GND	Device ground. Negative side of a telephone line, typically Ring side.
4	NC	No Connect. Open Circuit. No internal connections to the device.
5	LS	Line switch input. Input logic high turns on the hook switch. Internally pulled low with a high value resistor.
6	DP	For HT18. Dial pulse input. Input logic high turns off the hook switch. Used for pulse dialing. Internally pulled low with a high value resistor.
6	\overline{DP}	For HT19. Dial pulse input. Input logic low turns off the hook switch. Used for pulse dialing. Internally pulled high with a high value resistor.
7	CS	Current sense input. An external resistor connected between CS and TP sets the current limit.
8	TP	Positive output side of a telephone line. Zener protection to prevent this output from rising above 18V is required.

Typical Application Circuit

