

Features

- Single power supply: 2.4V~3.3V
- Low standby current: 1μA (Typ.) at V_{DD}= 3V
- Auto power-off function
- Eight different sound sections
- Speaker or direct piezo application
- LED flash drive output
- Minimal external components

General Description

The HT2844 is a CMOS LSI chip designed for use in sound effect products. It is equipped with tone circuit, noise circuit, and other control logic to generate various sounds including rifle fire, machine gun, booming, door bell, Alarm,

and so forth. Customer's supplied sound source can be analyzed and programmed into an internal ROM by changing a mask layer during device fabrication. The HT2844 is suitable for various toy applications.

Pin Assignment

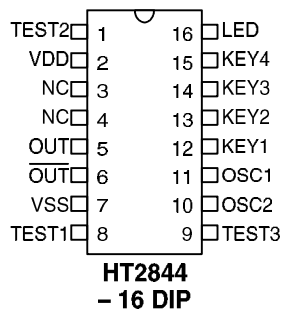

Pad Assignment

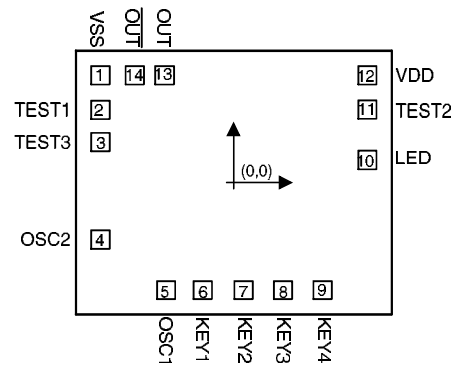

Chip size: 81 × 67 (mil)²

* The IC substrate should be connected to VDD in the PCB layout artwork.

Block Diagram

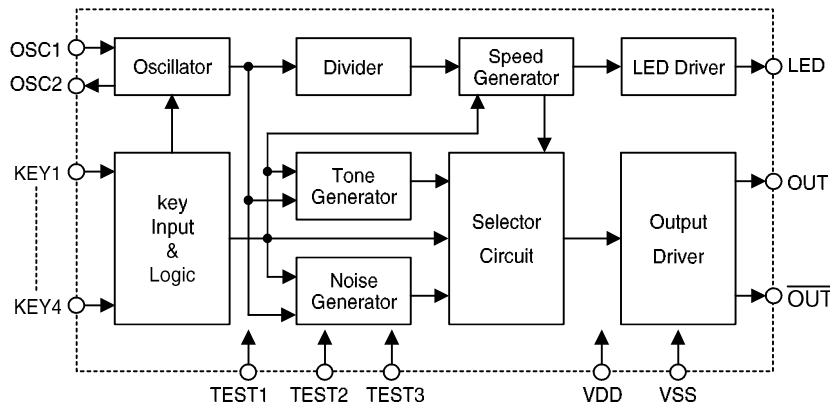

Pad Coordinates

Unit: mil

Pad No.	X	Y	Pad No.	X	Y
1	-33.53	27.05	8	12.45	-27.04
2	-33.53	18.30	9	22.40	-27.04
3	-33.53	10.22	10	33.62	5.72
4	-33.53	-14.34	11	33.62	18.38
5	-16.96	-27.04	12	33.62	27.05
6	-7.43	-27.04	13	-17.17	27.05
7	2.51	-27.04	14	-24.86	27.05

Pin Description

Pin No.	Pin Name	I/O	Description
1	TEST2	I/O	For IC test only
2	VDD	—	Positive power supply
3	NC	—	No connection
4	NC	—	No connection
5	OUT	O	Sound output
6	$\overline{\text{OUT}}$	O	Sound output, out of phase to pin 5
7	VSS	—	Negative power supply, GND
8	TEST1	I	For IC test only
9	TEST3	I/O	For IC test only
10	OSC2	O	Oscillator output
11	OSC1	I	Oscillator input

Pin No.	Pin Name	I/O	Description
12	KEY1	I	KEY1 input, low active
13	KEY2	I	KEY2 input, low active
14	KEY3	I	KEY3 input, low active
15	KEY4	I	KEY4 input, low active
16	LED	O	LED flash output

Absolute Maximum Ratings*

Supply Voltage -0.3V to 5V Storage Temperature..... -50°C to 125°C

Input Voltage..... V_{SS}-0.3 to V_{DD}+0.3V Operating Temperature..... 0°C to 70°C

*Note: Stresses above those listed under “Absolute Maximum Ratings” may cause permanent damage to the device. These are stress ratings only. Functional operation of this device at these or any other conditions above those indicated in the operational sections of this specification is not implied and exposure to absolute maximum rating conditions for extended periods may affect device reliability.

Electrical Characteristics

 (T_a=25°C)

Symbol	Parameter	Test Conditions		Min.	Typ.	Max.	Unit
		V _{DD}	Conditions				
V _{DD}	Operating Voltage	—	—	2.4	3	3.3	V
I _{STB}	Standby Current	3V	—	—	1	5	μA
I _{DD}	Operating Current	3V	No load	—	300	600	μA
I _{OH}	OUT Source Current	3V	V _{OH} =2.5V	-1	-2	—	mA
I _{OL}	OUT Sink Current	3V	V _{OL} =0.5V	1	2	—	mA
I _{LED}	LED Source Current	3V	V _{OL} =2.5V	-1	-2	—	mA
F _{OSC}	Oscillator Frequency	—	R=220kΩ	—	128	—	kHz
V _{IH}	“H” Input Voltage	3V	—	2.4	—	—	V
V _{IL}	“L” Input Voltage	3V	—	—	—	0.6	V

Timing Diagram

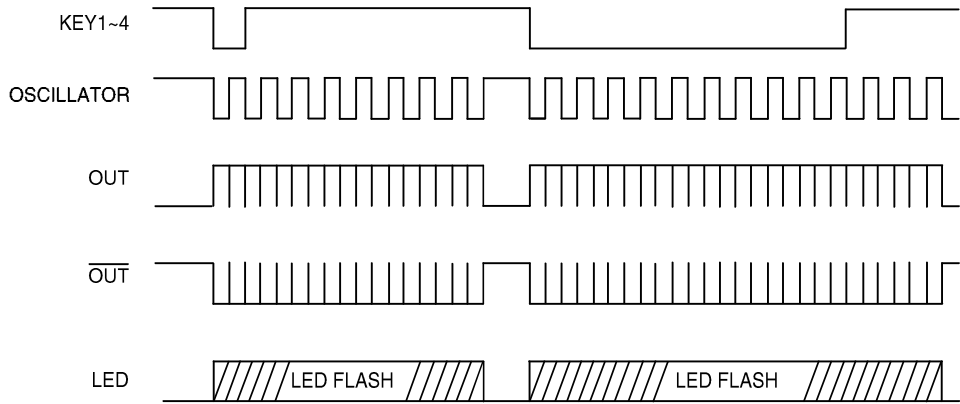

Application Circuits (HT2844 — Four Toy Gun Sounds)

- Speaker application

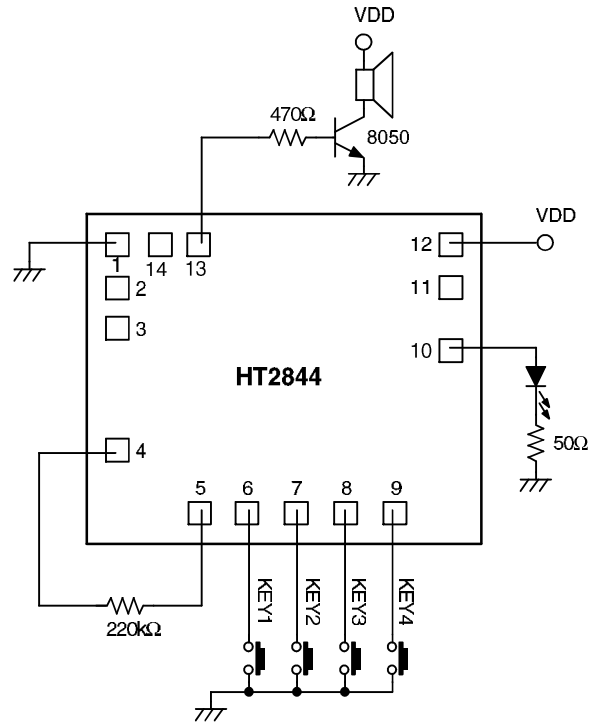

* The IC substrate should be connected to VDD in the PCB layout artwork.

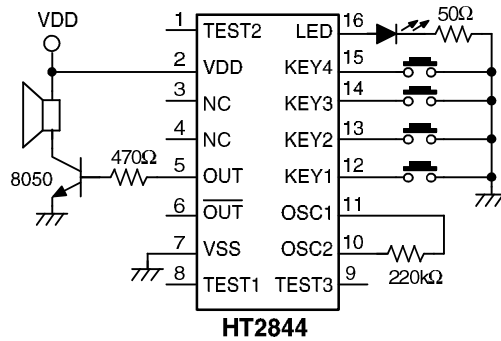

KEY1: Rifle Gun KEY3: Bombing
 KEY2: TV Game KEY4: Machine Gun

- Piezo application

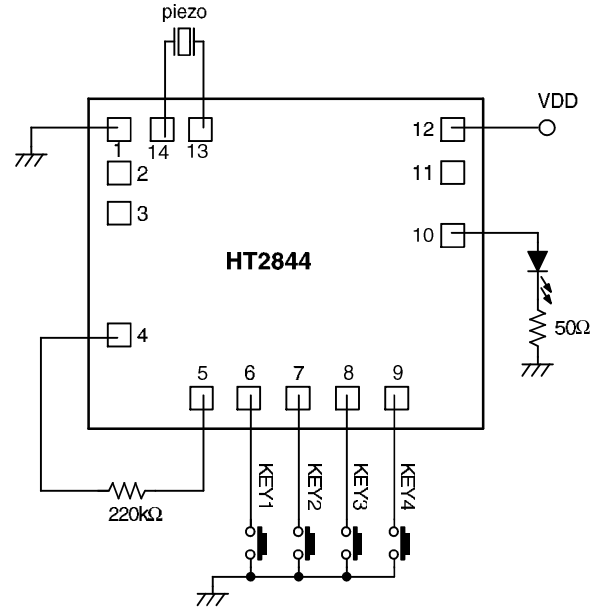

* The IC substrate should be connected to VDD in the PCB layout artwork.

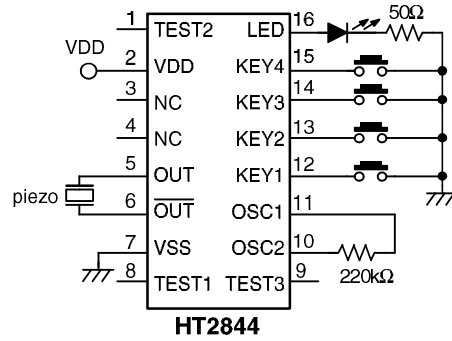

KEY1: Rifle Gun KEY3: Bombing
 KEY2: TV Game KEY4: Machine Gun

Application Circuits (HT2844C — Four Animal Sounds)

- Speaker application

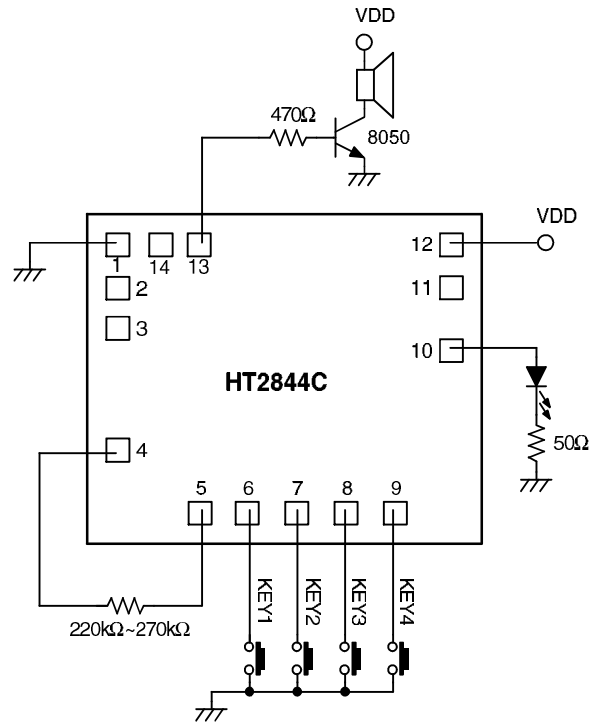

* The IC substrate should be connected to VDD in the PCB layout artwork.

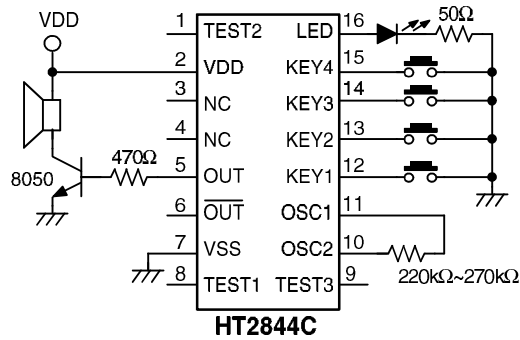

KEY1: Small Chicken KEY3: Frog
KEY2: Cricket KEY4: Bird

• Piezo application

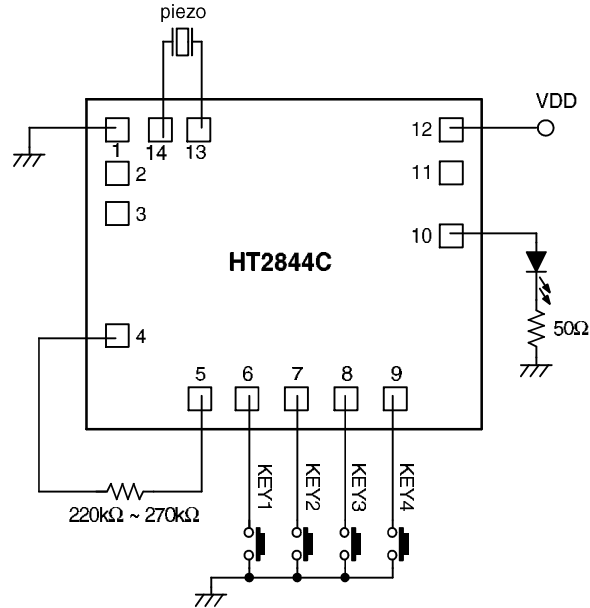

* The IC substrate should be connected to VDD in the PCB layout artwork.

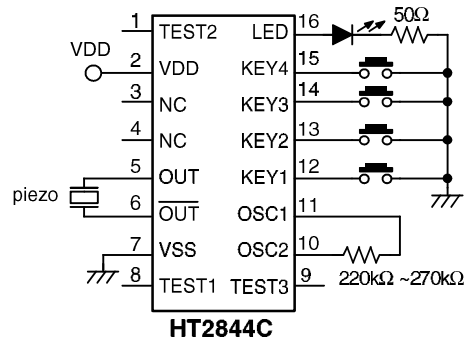

KEY1: Small Chicken KEY3: Frog
KEY2: Cricket KEY4: Bird

Application Circuits (HT2844M — Four Helicopter Sounds)

- Speaker application

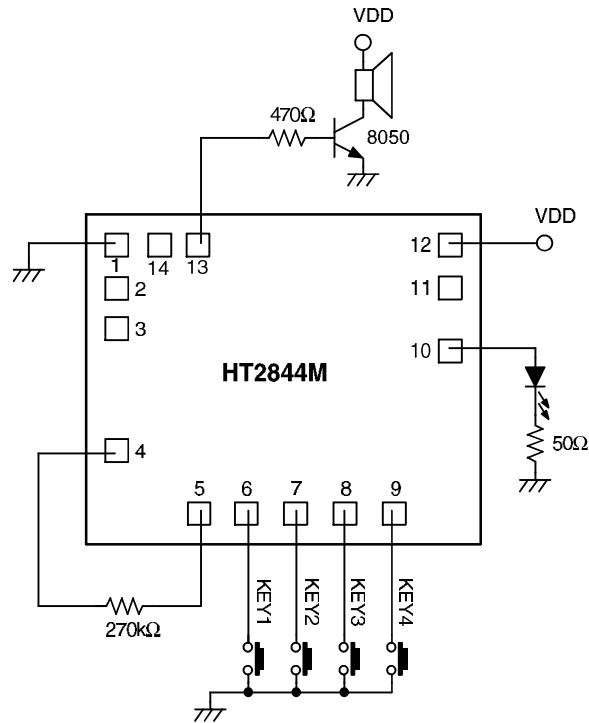

* The IC substrate should be connected to VDD in the PCB layout artwork.

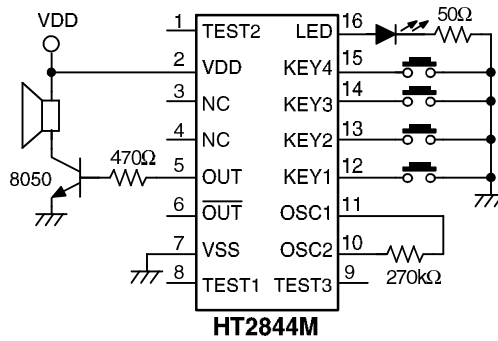

KEY1: High speed sound of propeller
KEY2: Low speed sound of propeller

KEY3: Explosion
KEY4: Machine Gun

• Piezo application

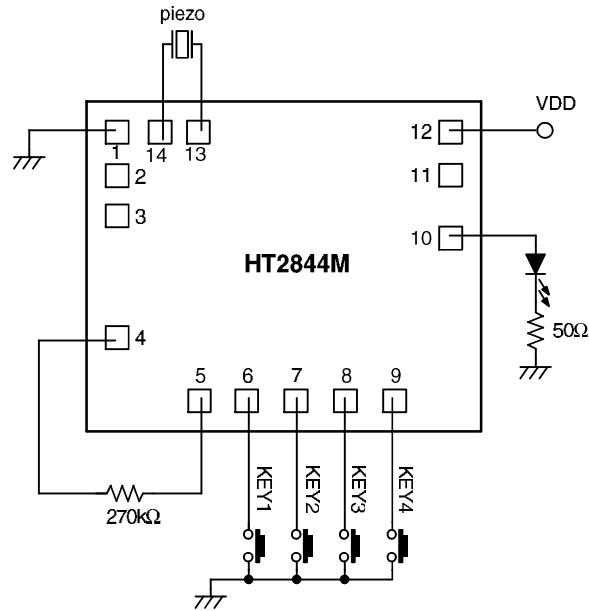

* The IC substrate should be connected to VDD in the PCB layout artwork.

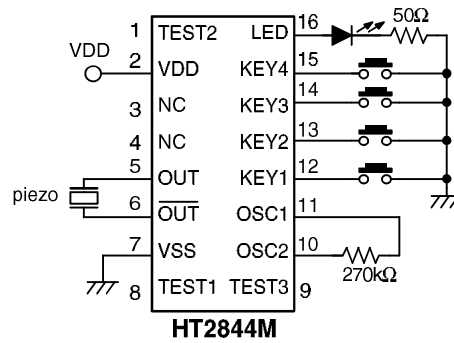

KEY1: High speed sound of propeller KEY3: Explosion
 KEY2: Low speed sound of propeller KEY4: Machine Gun

Application Circuits (HT2844N — Four Racing Car Sounds)

- Speaker application

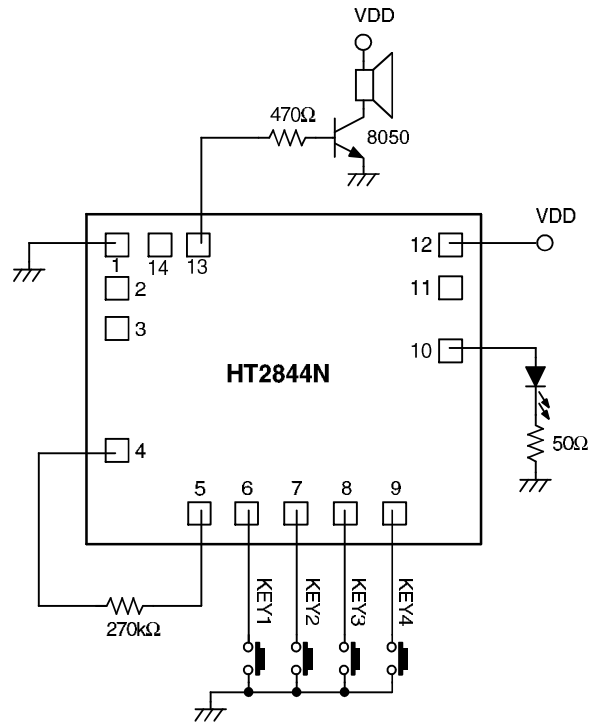

* The IC substrate should be connected to VDD in the PCB layout artwork.

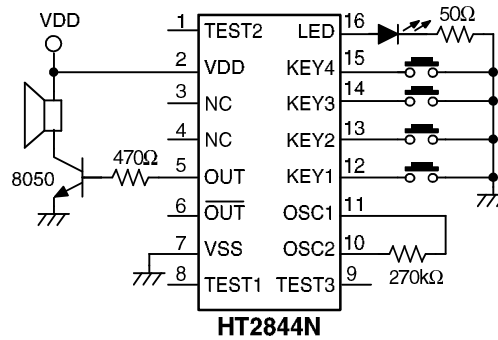

KEY1: Low speed sound of engine
KEY2: High speed sound of engine

KEY3: Horn
KEY4: Brake

• Piezo application

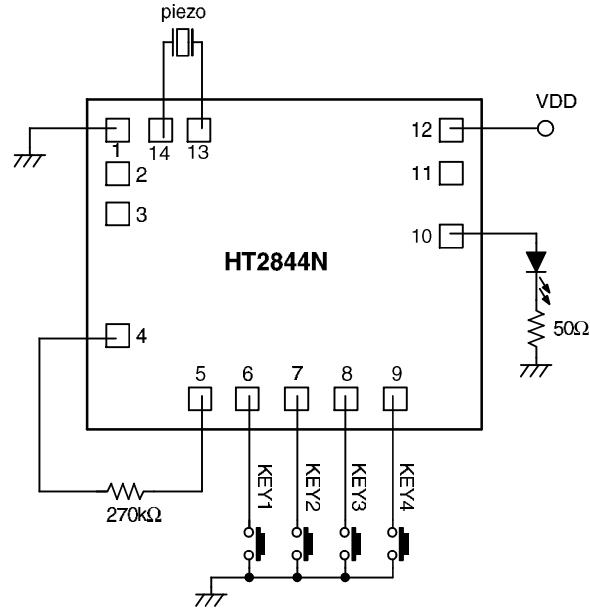

* The IC substrate should be connected to VDD in the PCB layout artwork.

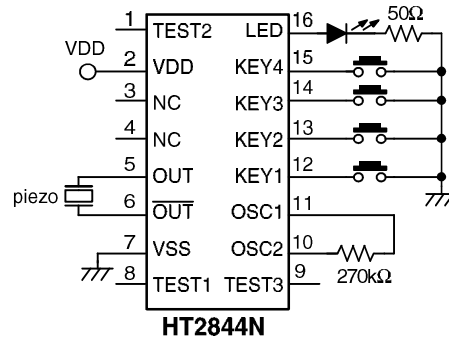

KEY1: Low speed sound of engine KEY3: Horn
 KEY2: High speed sound of engine KEY4: Brake

Application Circuits (HT2844P — Four Jet aircraft Sounds)

- Speaker application

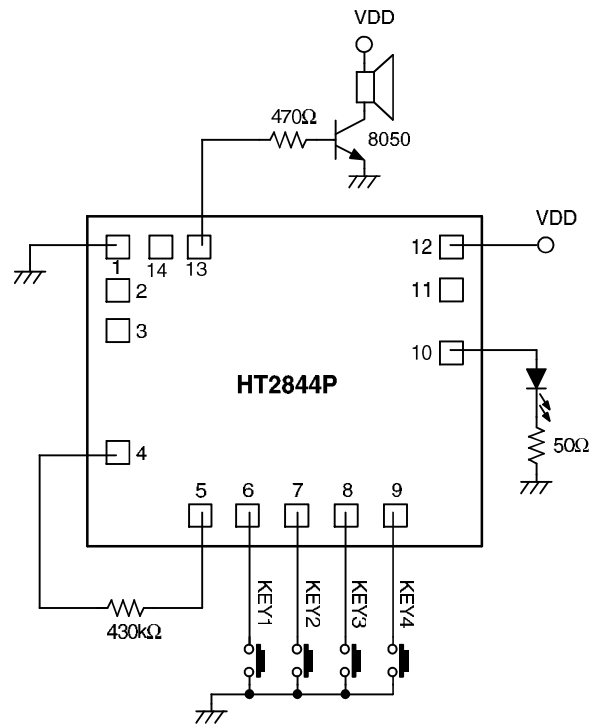

* The IC substrate should be connected to VDD in the PCB layout artwork.

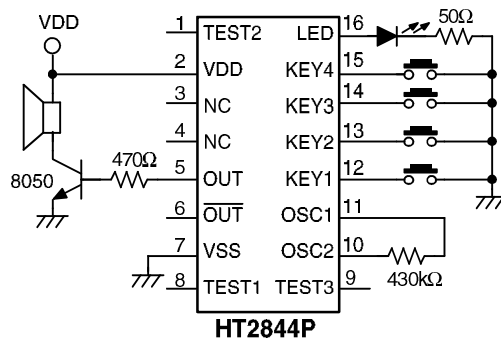

KEY1: Low speed sound of aircraft KEY3: Missile
 KEY2: High speed sound of aircraft KEY4: Machine Gun

• Piezo application

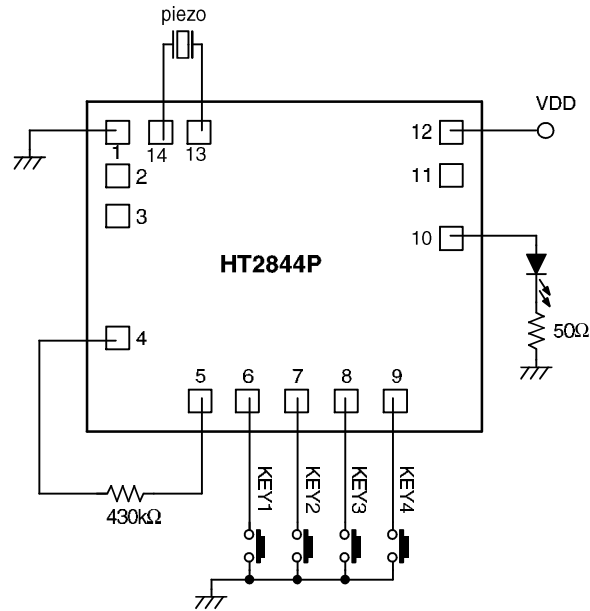

* The IC substrate should be connected to VDD in the PCB layout artwork.

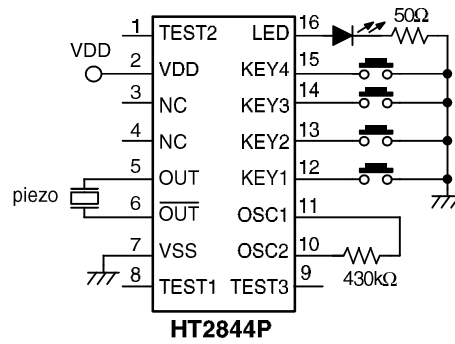

KEY1: Low speed sound of aircraft KEY3: Missile
 KEY2: High speed sound of aircraft KEY4: Machine Gun

Application Circuits (HT2844S — Four Morning Call Sounds)

- Speaker application

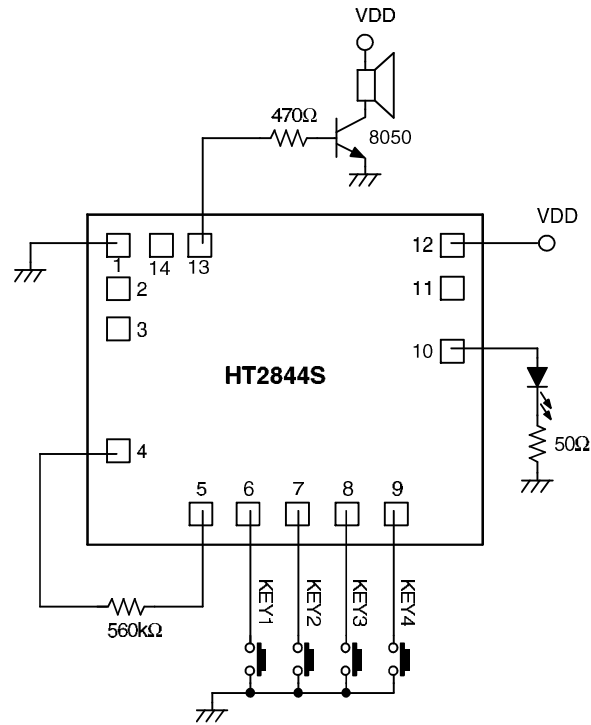

* The IC substrate should be connected to VDD in the PCB layout artwork.

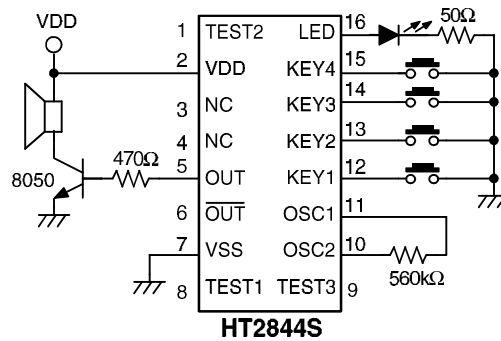

KEY1: Phone KEY3: Ambulance
 KEY2: Siren KEY4: Melody (London bridge is falling down)

• Piezo application

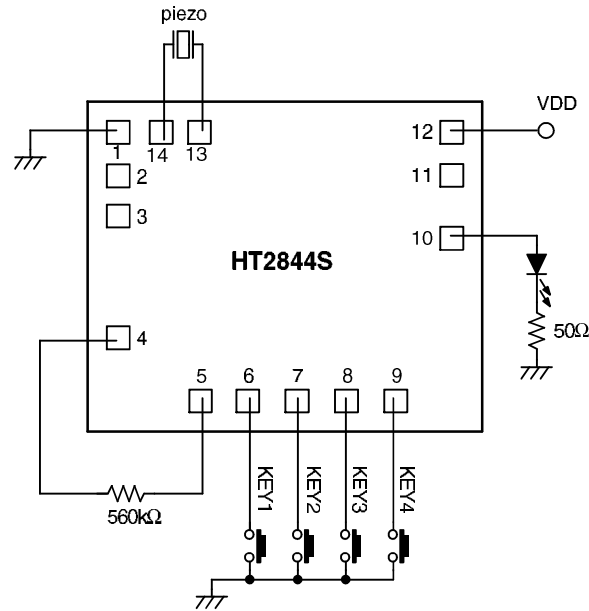

* The IC substrate should be connected to VDD in the PCB layout artwork.

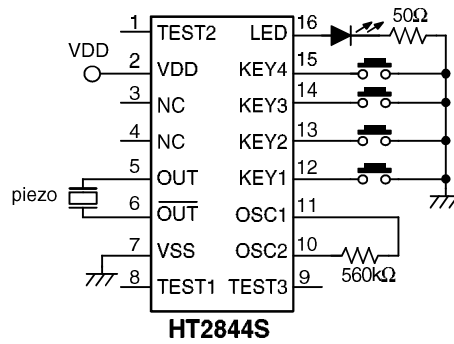

KEY1: Phone KEY3: Ambulance
 KEY2: Siren KEY4: Melody (London bridge is falling down)

Application Circuits (HT2844T — Four Alarm Sounds)

- Speaker application

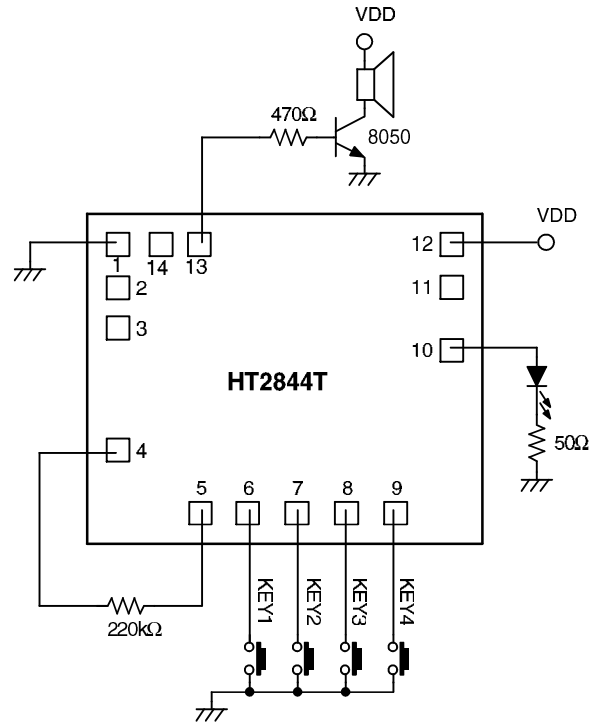

* The IC substrate should be connected to VDD in the PCB layout artwork.

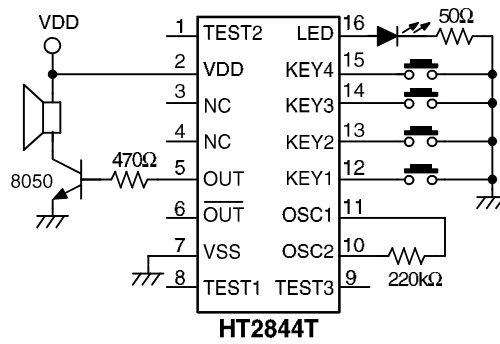

• Piezo application

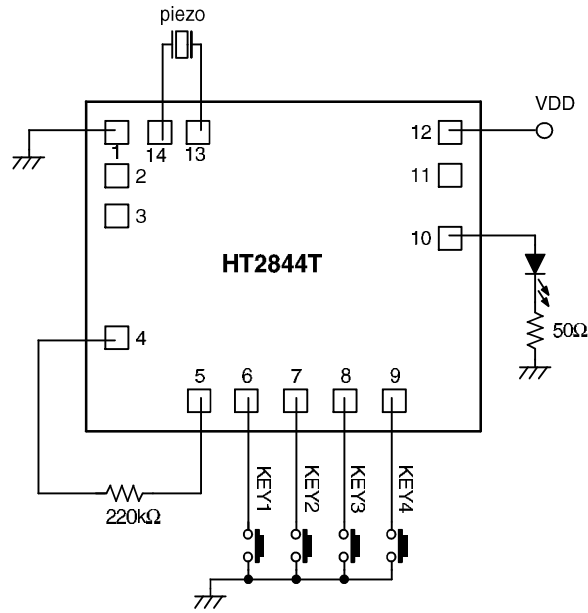

* The IC substrate should be connected to VDD in the PCB layout artwork.

