

### Technical Document

- [Tools Information](#)
- [FAQs](#)
- [Application Note](#)

### Features

- Input voltage: 3.0V~5.5V
- Built-in seven circuits
  - 2-level output:
    - 2 circuits for vertical CCD clock driver output voltage level (typ.) = -9V to 0V
  - 3-level output:
    - 2 circuits for vertical CCD clock driver output voltage level (typ.) = -9V to 15V
- 2-level output:
  - 1 circuit for shutter driver output voltage level (typ.) = -9V to 15V
- Switchable between NTSC (EIA) and PAL (CCIR) modes
- 16-pin SSOP/TSSOP package

### General Description

HT82V805 is a CMOS vertical clock driver and shutter driver IC for CCD area sensors. It has the capability of

converting the voltage and impedance from the CMOS level.

### Block Diagram

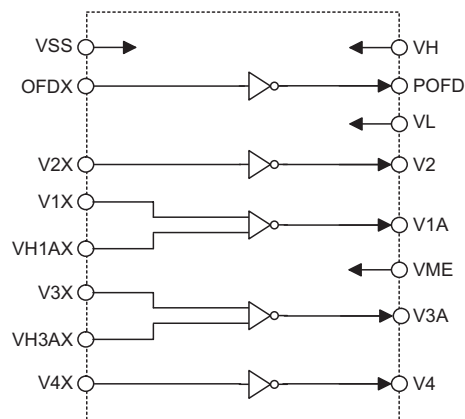

### Pin Assignment

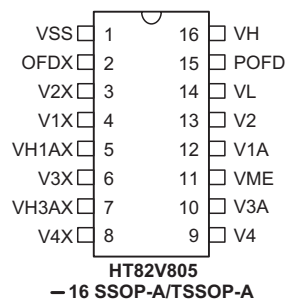

**Pin Description**

Pin No.	Pin Name	I/O	Description
1	VSS	—	Negative power supply, ground
2	OFDX	I	Electronic shutter pulse input
4, 3, 6, 8	V1X, V2X, V3X, V4X	I	Vertical transfer pulse input
5, 7	VH1AX, VH3AX	I	Pulse that transfers the charge of the photo-diode to the vertical shift register.
9	V4	O	Pulse to drive vertical CCD shift register (2 level: VME, VL)
10	V3A	O	Pulse to drive vertical CCD shift register (3 level: VME, VL, VH)
11	VME	—	Power supply for intermediate level of V1A, V3A
12	V1A	O	Pulse to drive vertical CCD shift register (3 level: VME, VL, VH)
13	V2	O	Pulse to drive vertical CCD shift register (2 level: VME, VL)
14	VL	—	Power supply for all low level output pulses
15	POFD	O	Electronic shutter pulse output (2 level: VL, VH)
16	VH	—	Power supply for high level of V1A, V3A

**Absolute Maximum Ratings**

Supply Voltage .....	$V_{SS}-0.3V$ to $V_L+35V$	Storage Temperature .....	$-55^{\circ}C$ to $150^{\circ}C$
Input Voltage .....	$V_{SS}-0.3V$ to $V_H+0.3V$	Operating Temperature .....	$-25^{\circ}C$ to $70^{\circ}C$

Note: These are stress ratings only. Stresses exceeding the range specified under "Absolute Maximum Ratings" may cause substantial damage to the device. Functional operation of this device at other conditions beyond those listed in the specification is not implied and prolonged exposure to extreme conditions may affect device reliability.

**Recommended Operating Conditions**

Symbol	Parameter	Value	Unit
$V_H$	Supply Voltage	$-0.3 \sim V_L+35$	V
$V_L$		$0 \sim -10$	V
VME		$V_L-0.3 \sim 3.0$	V
V1A, V2, V3A, V4, POFD	Output Voltage	$V_L-0.3 \sim V_H+0.3$	V

**Logic Function Table**

Input				Output		
V1X, V3X	VH1AX, VH3AX	V2X, V4X	OFDX	V1A, V3A	V2, V4	POFD
L	L	—	—	VH	—	—
H	L	—	—	Z	—	—
L	H	—	—	VME	—	—
H	H	—	—	VL	—	—
—	—	L	—	—	VME	—
—	—	H	—	—	VL	—
—	—	—	L	—	—	VH
—	—	—	H	—	—	VL

**D.C. Characteristics**
 $V_H=15V, V_L=-9V, V_{ME}=0V, T_a=25^\circ C$ 

Symbol	Parameter	Test Conditions	Min.	Typ.	Max.	Unit
$V_{DD}$	Logic Supply Voltage	—	3.0	3.3	5.5	V
$V_H$	Supply Voltage	—	14.5	15	15.5	V
$V_L$	Supply Voltage	—	-9.5	-8.5	-7.5	V
$V_{IH}$	High Level Input Voltage	—	2.4	—	—	V
$V_{IL}$	Low Level Input Voltage	—	—	—	1.2	V
$I_{VH}$	Operating Current	Shutter speed=100kHz	—	3.8	—	mA
$I_{VL}$			—	-2	—	mA
$I_{VME}$			—	-6.5	—	mA
$I_{OL}$	Output Current	$V1A, V2, V3A, V4=-9.0V$	—	37	—	mA
$I_{OM1}$		$V1A, V2, V3A, V4=-0.5V$	—	-15	—	mA
$I_{OM2}$		$V1A, V3A=0.5V$	—	13.5	—	mA
$I_{OH}$		$V1A, V3A=14.5V$	—	-18	—	mA
$I_{OSL}$		$OFDX=-8.0V$	—	18	—	mA
$I_{OSH}$		$OFDX=14.5V$	—	-10.5	—	mA

**A.C. Characteristics**
 $T_a=25^\circ C$ 

Symbol	Parameter	Test Conditions	Min.	Typ.	Max.	Unit
$t_{PLM}$	Delay Time	$V_H=15V, V_L=-8.5V, V_{ME}=0V$	—	55	80	ns
$t_{PMH}$		$V_H=15V, V_L=-8.5V, V_{ME}=0V$	—	50	90	ns
$t_{PLH}$		$V_H=15V, V_L=-8.5V, V_{ME}=0V$	—	55	100	ns
$t_{PML}$		$V_H=15V, V_L=-8.5V, V_{ME}=0V$	—	45	130	ns
$t_{PHM}$		$V_H=15V, V_L=-8.5V, V_{ME}=0V$	—	50	120	ns
$t_{PHL}$		$V_H=15V, V_L=-8.5V, V_{ME}=0V$	—	55	100	ns
$t_{TLM}$	Rising Time	$V_H=15V, V_L=-8.5V, V_{ME}=0V$	—	370	900	ns
$t_{TMH}$		$V_H=15V, V_L=-8.5V, V_{ME}=0V$	—	785	900	ns
$t_{TLH}$		$V_H=15V, V_L=-8.5V, V_{ME}=0V$	—	70	140	ns
$t_{TML}$		$V_H=15V, V_L=-8.5V, V_{ME}=0V$	—	300	700	ns
$t_{THM}$		$V_H=15V, V_L=-8.5V, V_{ME}=0V$	—	630	960	ns
$t_{THL}$		$V_H=15V, V_L=-8.5V, V_{ME}=0V$	—	45	120	ns

**Timing Diagrams**

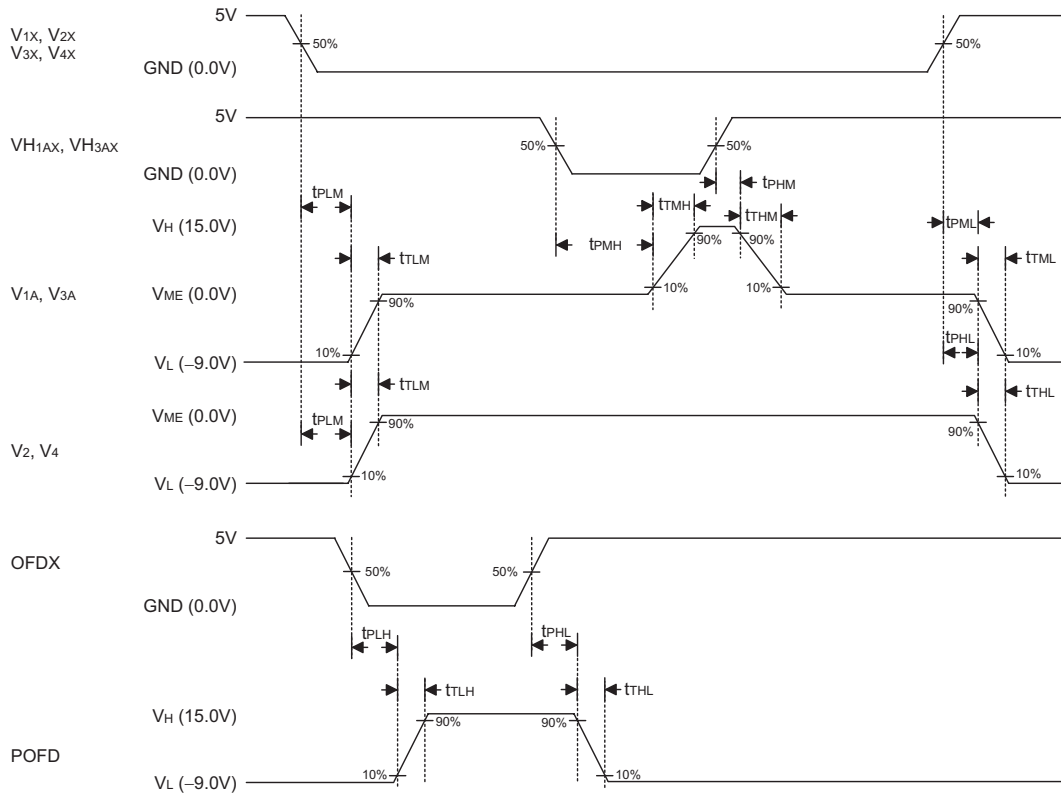

**Application Circuits**

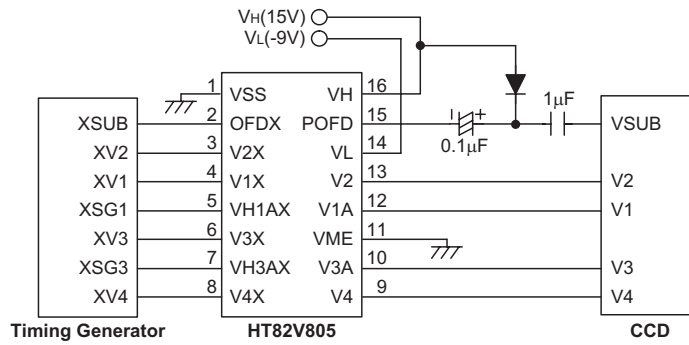

**Equivalent Circuits**

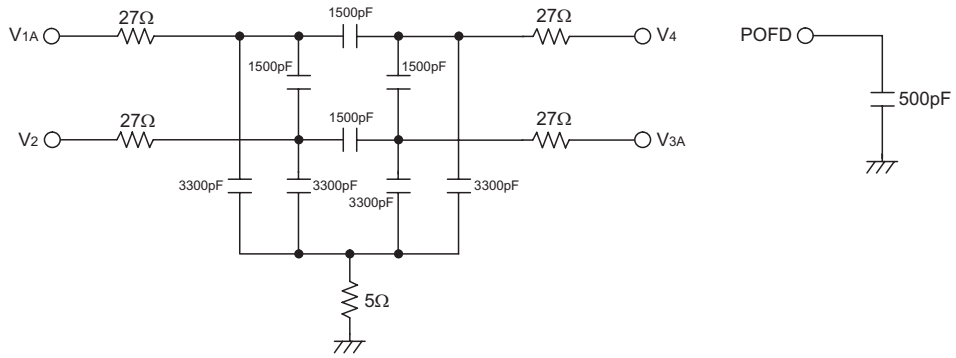

**Package Information**

**16-pin SSOP (150mil) Outline Dimensions**

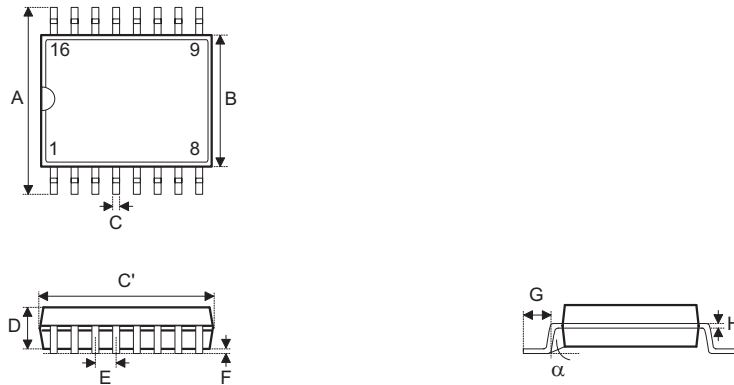

Symbol	Dimensions in mil		
	Min.	Nom.	Max.
A	228	—	244
B	150	—	157
C	8	—	12
C'	189	—	197
D	54	—	60
E	—	25	—
F	4	—	10
G	22	—	28
H	7	—	10
$\alpha$	0°	—	8°

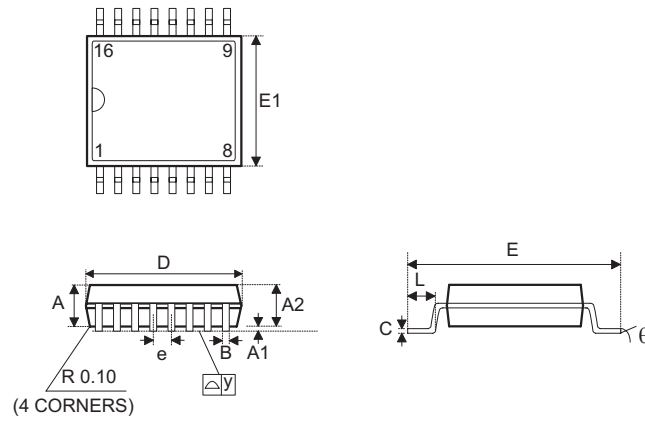
**16-pin TSSOP Outline Dimensions**

Symbol	Dimensions in mm		
	Min.	Nom.	Max.
A	1	—	1.05
A1	0.05	—	0.15
A2	1.05	—	1.2
B	—	0.25	—
C	0.11	—	0.15
D	4.9	—	5.1
E	6.2	—	6.6
E1	4.3	—	4.5
e	—	0.65	—
L	0.5	—	0.7
y	—	—	0.076
$\theta$	0°	—	8°

**Product Tape and Reel Specifications**

**Reel Dimensions**

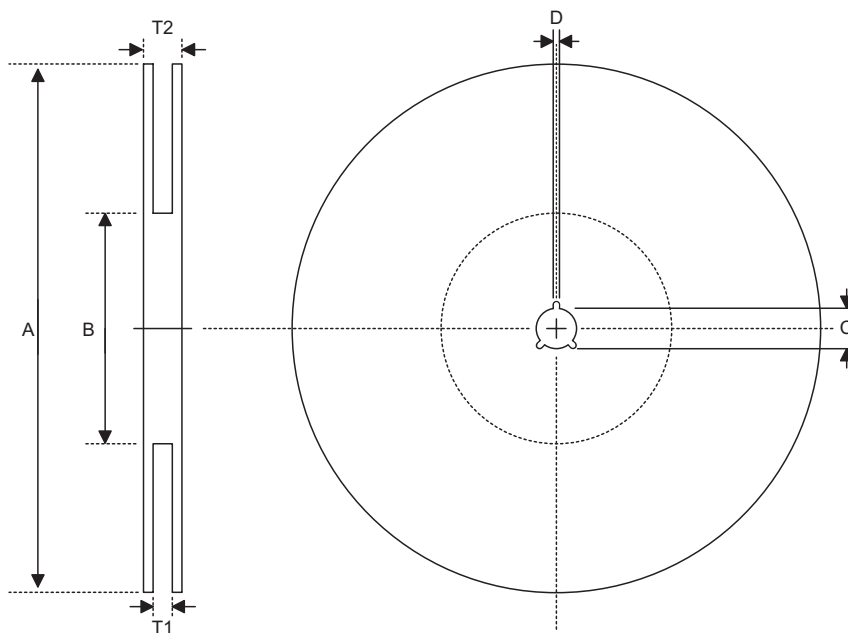

**SSOP 16S**

Symbol	Description	Dimensions in mm
A	Reel Outer Diameter	330±1.0
B	Reel Inner Diameter	62±1.5
C	Spindle Hole Diameter	13.0+0.5 -0.2
D	Key Slit Width	2.0±0.5
T1	Space Between Flange	12.8+0.3 -0.2
T2	Reel Thickness	18.2±0.2

**TSSOP 16L**

Symbol	Description	Dimensions in mm
A	Reel Outer Diameter	330±1
B	Reel Inner Diameter	62±1.5
C	Spindle Hole Diameter	13+0.5 -0.2
D	Key Slit Width	2±0.5
T1	Space Between Flange	16.8+0.3 -0.2
T2	Reel Thickness	22.2±0.2

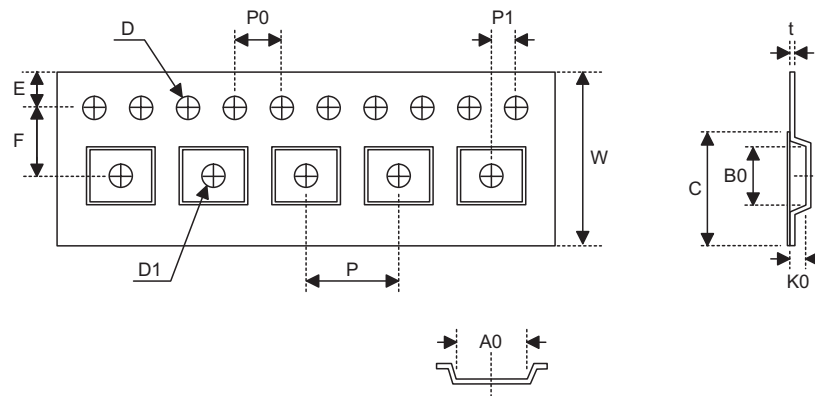

**Carrier Tape Dimensions**

**SSOP 16S**

Symbol	Description	Dimensions in mm
W	Carrier Tape Width	12.0+0.3 -0.1
P	Cavity Pitch	8.0±0.1
E	Perforation Position	1.75±0.1
F	Cavity to Perforation (Width Direction)	5.5±0.1
D	Perforation Diameter	1.55±0.1
D1	Cavity Hole Diameter	1.5+0.25
P0	Perforation Pitch	4.0±0.1
P1	Cavity to Perforation (Length Direction)	2.0±0.1
A0	Cavity Length	6.4±0.1
B0	Cavity Width	5.2±0.1
K0	Cavity Depth	2.1±0.1
t	Carrier Tape Thickness	0.30±0.05
C	Cover Tape Width	9.3

**TSSOP 16L**

Symbol	Description	Dimensions in mm
W	Carrier Tape Width	16+0.3 -0.1
P	Cavity Pitch	8±0.1
E	Perforation Position	1.75±0.1
F	Cavity to Perforation (Width Direction)	7.5±0.5
D	Perforation Diameter	1.5+0.1
D1	Cavity Hole Diameter	1.5+0.1
P0	Perforation Pitch	4±0.1
P1	Cavity to Perforation (Length Direction)	2±0.1
A0	Cavity Length	6.8±0.1
B0	Cavity Width	5.4±0.1
K0	Cavity Depth	1.6±0.1
t	Carrier Tape Thickness	0.3±0.013
C	Cover Tape Width	13.3

**Holtek Semiconductor Inc. (Headquarters)**

No.3, Creation Rd. II, Science Park, Hsinchu, Taiwan  
Tel: 886-3-563-1999  
Fax: 886-3-563-1189  
<http://www.holtek.com.tw>

**Holtek Semiconductor Inc. (Taipei Sales Office)**

4F-2, No. 3-2, YuanQu St., Nankang Software Park, Taipei 115, Taiwan  
Tel: 886-2-2655-7070  
Fax: 886-2-2655-7373  
Fax: 886-2-2655-7383 (International sales hotline)

**Holtek Semiconductor Inc. (Shanghai Sales Office)**

7th Floor, Building 2, No.889, Yi Shan Rd., Shanghai, China 200233  
Tel: 021-6485-5560  
Fax: 021-6485-0313  
<http://www.holtek.com.cn>

**Holtek Semiconductor Inc. (Shenzhen Sales Office)**

43F, SEG Plaza, Shen Nan Zhong Road, Shenzhen, China 518031  
Tel: 0755-8346-5589  
Fax: 0755-8346-5590  
ISDN: 0755-8346-5591

**Holtek Semiconductor Inc. (Beijing Sales Office)**

Suite 1721, Jinyu Tower, A129 West Xuan Wu Men Street, Xicheng District, Beijing, China 100031  
Tel: 010-6641-0030, 6641-7751, 6641-7752  
Fax: 010-6641-0125

**Holmate Semiconductor, Inc. (North America Sales Office)**

46712 Fremont Blvd., Fremont, CA 94538  
Tel: 510-252-9880  
Fax: 510-252-9885  
<http://www.holmate.com>

Copyright © 2005 by HOLTEK SEMICONDUCTOR INC.

The information appearing in this Data Sheet is believed to be accurate at the time of publication. However, Holtek assumes no responsibility arising from the use of the specifications described. The applications mentioned herein are used solely for the purpose of illustration and Holtek makes no warranty or representation that such applications will be suitable without further modification, nor recommends the use of its products for application that may present a risk to human life due to malfunction or otherwise. Holtek's products are not authorized for use as critical components in life support devices or systems. Holtek reserves the right to alter its products without prior notification. For the most up-to-date information, please visit our web site at <http://www.holtek.com.tw>.