

## 64-Channel Serial To Parallel Converter With Open Drain Outputs

### Ordering Information

Device	Package Options	
	80-Lead Quad Plastic Gullwing	Die
HV3137	HV3137PG	HV3137X

### Features

- HVCMOS® technology
- Output voltages up to 375V
- Sink current minimum 1 mA
- Shift register speed 6 MHz
- Latched outputs
- CMOS compatible inputs
- Forward and reverse shifting options

### General Description

The HV31 is a low voltage serial to high voltage parallel converter with open drain outputs. It has been designed especially for use as a driver for electrostatic printers.

This device consists of a 64-bit shift register, 64 latches, latch enable ( $\overline{LE}$ ), and output enable (OE). Data is shifted through the shift register on the high to low transition of the clock. When the DIR pin is set high, the HV31 shifts in the counterclockwise direction when viewed from the top of the package. When the DIR pin is set low, the HV31 shifts in the clockwise direction. A serial data output buffer is provided for cascading devices. This output reflects the current status of the last bit of the shift register. Operation of the shift register is not affected by the  $\overline{LE}$  or the OE inputs. Transfer of data from the shift register to the latch occurs when the LE input is high. The data in the latch is stored when LE is low.

### Absolute Maximum Ratings<sup>1</sup>

Supply voltage, $V_{DD}$	-0.5V to +9V
Supply voltage, $V_{PP}$	-0.5V to +400V
Logic input levels	-0.5V to $V_{DD} + 0.5V$
Ground current <sup>2</sup>	0.75A
Continuous total power dissipation <sup>2</sup>	1200mW
Operating temperature range	-40°C to +85°C
Storage temperature range	-65°C to +150°C

**Notes:**

1. All voltages are referenced to GND.
2. For operation above 25°C ambient derate linearly by 20mW/°C up to 85°C.

# Electrical Characteristics (over recommended operating conditions unless noted)

## DC Characteristics

Symbol	Parameter	Min	Typ	Max	Units	Conditions
$I_{DD}$	$V_{DD}$ Supply Current			15	mA	$f_{CLK} = 6\text{MHz}$ , $f_{DATA} = 3\text{MHz}$ $\overline{LE} = \text{LOW}$
$I_{DDQ}$	Quiescent $V_{DD}$ Supply Current			250	$\mu\text{A}$	All $V_{IN} = 0\text{V}$
$I_{O(OFF)}$	Off State Output Current at 25°C, per Switch			100	nA	Output high, and at 375V
$I_{IH}$	High-Level Logic Input Current			10	$\mu\text{A}$	$V_{IH} = V_{DD}$
$I_{IL}$	Low-Level Logic Input Current			-10	$\mu\text{A}$	$V_I = 0\text{V}$
$V_{OH}$	High-Level Data Out	$V_{DD} - 1\text{V}$			V	$I_{DOUT} = -100\mu\text{A}$
$V_{OL}$	Low-Level Output	$HV_{OUT}$		10	V	$I_{HV_{OUT}} = +1\text{mA}$
		Data Out		1	V	$I_{DOUT} = +100\mu\text{A}$
$V_{OC}$	$HV_{OUT}$ Clamp Voltage			-3.0	V	$I_{OL} = -1\text{mA}$
$C_{HVO}$	Output Capacitance per Channel			3	pF	$V_{DS} = 100\text{V}$

## AC Characteristics

Symbol	Parameter	Min	Typ	Max	Units	Conditions
$f_{CLK}$	Clock Frequency			6	MHz	
$t_W$	Clock Width High or Low	83			ns	
$t_{SU}$	Data Setup Time Before Clock Falls	35			ns	
$t_H$	Data Hold Time After Clock Falls	15			ns	
$t_{WLE}$	Width of Latch Enable Pulse	83			ns	
$t_{DLE}$	$\overline{LE}$ Delay Time After Falling Edge of Clock	35			ns	
$t_{SLE}$	$\overline{LE}$ Setup Time Before Falling Edge of Clock	40			ns	
$t_{DHL}$	Clock Delay Time Data High to Low			135	ns	
$t_{DLH}$	Clock Delay Time Data Low to High			135	ns	

## Recommended Operating Conditions

Symbol	Parameter	Min	Typ	Max	Units
$V_{DD}$	Logic supply voltage	4.5	5	5.5	V
$HV_{OUT}$	High voltage output	8.0		375	V
$V_{IH}$	High-level input voltage	3.5		$V_{DD}$	V
$V_{IL}$	Low-level input voltage	0		0.8	V
$T_A$	Operating free-air temperature	-40		+85	°C

### Notes:

Power-up sequence should be the following:

1. Connect ground.
2. Apply  $V_{DD}$ .
3. Set all inputs (Data, CLK, Enable, etc.) to a known state.
4. Apply  $V_{PP}$ .

Power-down sequence should be the reverse of the above.

# Input and Output Equivalent Circuits

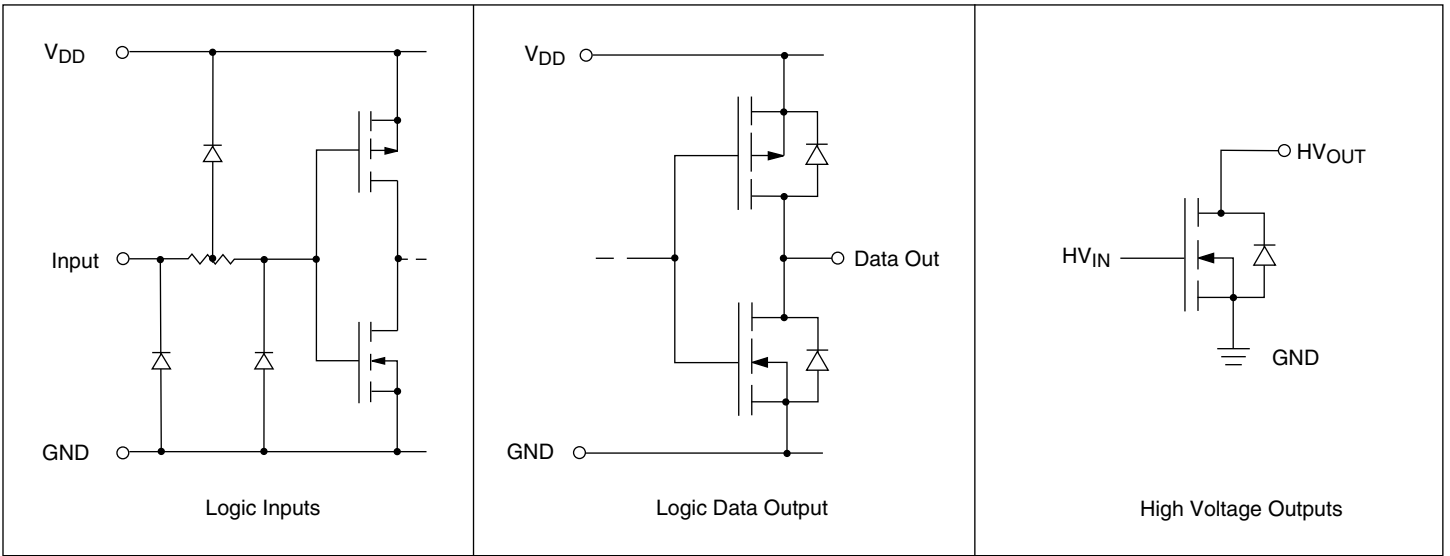

# Switching Waveforms

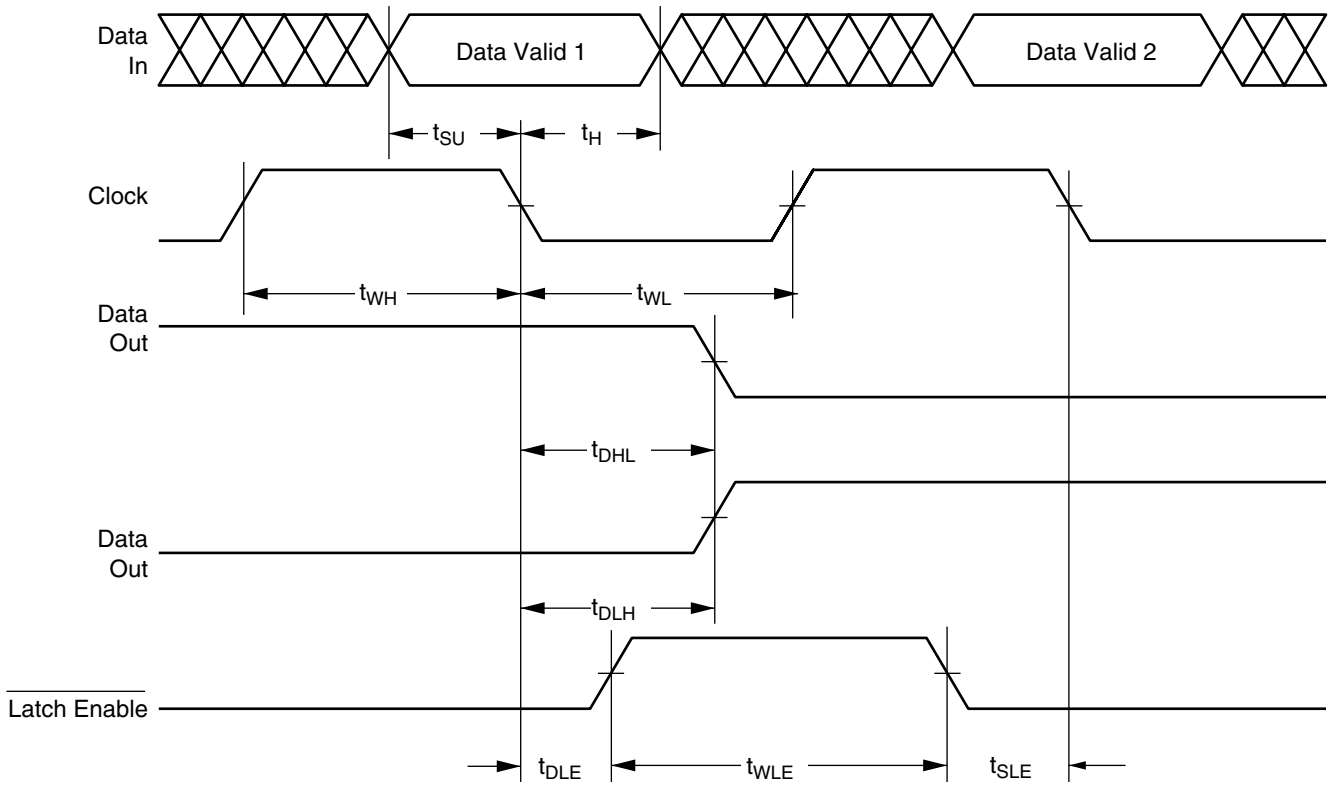

# Functional Block Diagram

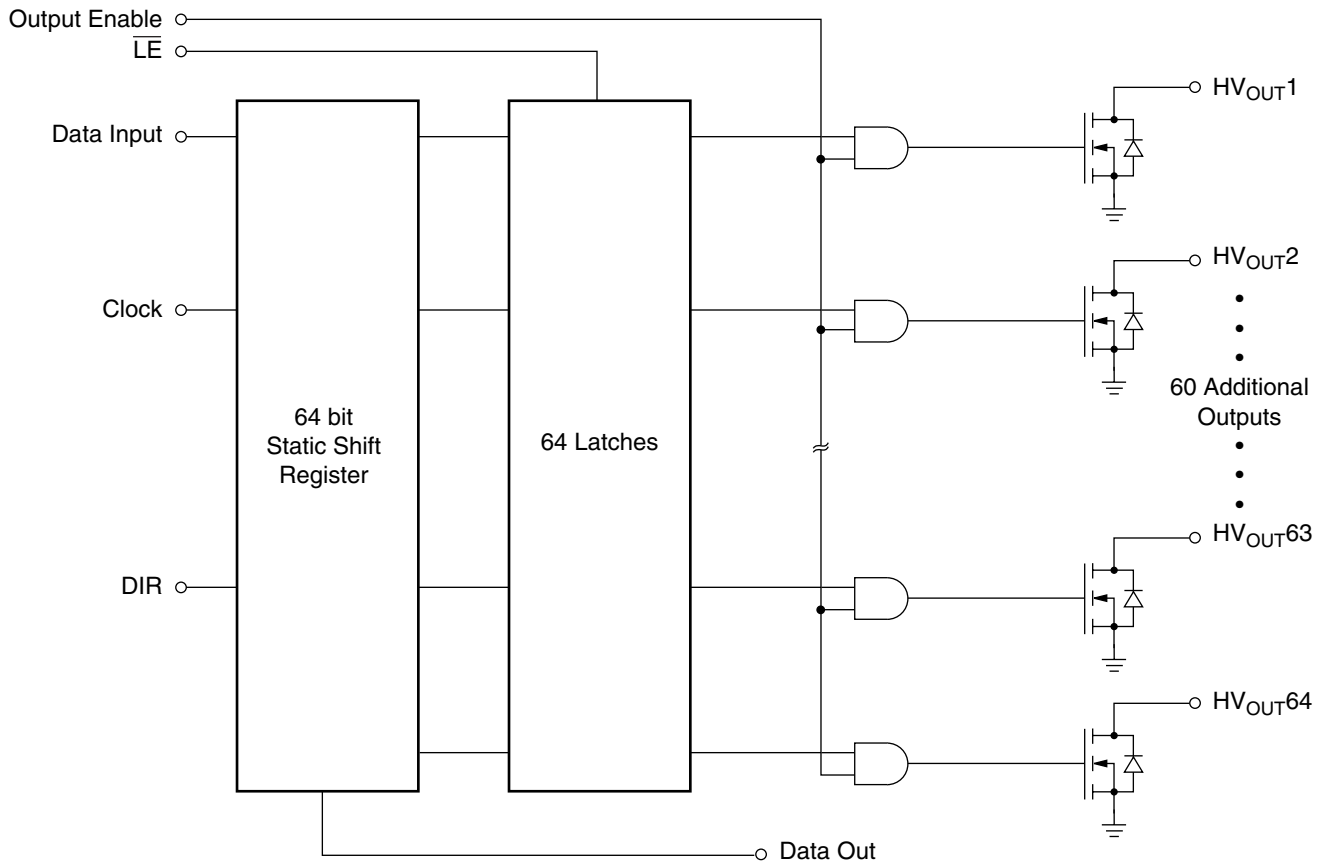

# Function Table

Function	Inputs					Outputs			
	Data	CLK	$\overline{LE}$	OE	DIR	Shift Reg 1 2 ... 64	Latch 1 2 ... 64	HV <sub>OUT</sub> 1 2 ... 64	D <sub>OUT</sub>
All off	X	X	X	L	X	*...*	*...*	OFF...OFF	*
Load S/R	H or L	↓	L	L	H	H or L...Q <sub>n</sub> → Q <sub>n+1</sub>	*...*	OFF...OFF	*
	H or L	↓	L	L	L	H or L...Q <sub>n</sub> → Q <sub>n-1</sub>	*...*	OFF...OFF	*
Load Latch	X	X	H	L	X	H or L...*	H or L...*	OFF...OFF	*
Output Enable	X	H or L	H	H	X	H or L...*	H or L...*	ON or OFF...*	*
Transparent Latch Mode	H	↓	H	H	X	H...*	H...*	ON ...*	*
	L	↓	H	H	X	L ...*	L...*	OFF...*	*

**Notes:**

- X = Don't care
- \* = Dependent on previous stage's state before the last CLK : High to low transition.
- ↓ = High to low transition
- H = High level
- L = Low level

# Pin Configurations

## PG and DG Packages

### HV31

Pin	Function	Pin	Function
1	GND	41	N/C
2	N/C	42	N/C
3	HV <sub>OUT</sub> 59/6	43	HV <sub>OUT</sub> 23/42
4	HV <sub>OUT</sub> 60/5	44	HV <sub>OUT</sub> 24/41
5	HV <sub>OUT</sub> 61/4	45	HV <sub>OUT</sub> 25/40
6	HV <sub>OUT</sub> 62/3	46	HV <sub>OUT</sub> 26/39
7	HV <sub>OUT</sub> 63/2	47	HV <sub>OUT</sub> 27/38
8	HV <sub>OUT</sub> 64/1	48	HV <sub>OUT</sub> 28/37
9	DIR	49	HV <sub>OUT</sub> 29/36
10	Data Out	50	HV <sub>OUT</sub> 30/35
11	CLK	51	HV <sub>OUT</sub> 31/34
12	GND	52	HV <sub>OUT</sub> 32/33
13	V <sub>DD</sub>	53	HV <sub>OUT</sub> 33/32
14	$\overline{LE}$	54	HV <sub>OUT</sub> 34/31
15	Data In	55	HV <sub>OUT</sub> 35/30
16	OE	56	HV <sub>OUT</sub> 36/29
17	HV <sub>OUT</sub> 1/64	57	HV <sub>OUT</sub> 37/28
18	HV <sub>OUT</sub> 2/63	58	HV <sub>OUT</sub> 38/27
19	HV <sub>OUT</sub> 3/62	59	HV <sub>OUT</sub> 39/26
20	HV <sub>OUT</sub> 4/61	60	HV <sub>OUT</sub> 40/25
21	HV <sub>OUT</sub> 5/60	61	HV <sub>OUT</sub> 41/24
22	HV <sub>OUT</sub> 6/59	62	HV <sub>OUT</sub> 42/23
23	N/C	63	N/C
24	HV <sub>OUT</sub> GND	64	N/C
25	HV <sub>OUT</sub> 7/58	65	HV <sub>OUT</sub> 43/22
26	HV <sub>OUT</sub> 8/57	66	HV <sub>OUT</sub> 44/21
27	HV <sub>OUT</sub> 9/56	67	HV <sub>OUT</sub> 45/20
28	HV <sub>OUT</sub> 10/55	68	HV <sub>OUT</sub> 46/19
29	HV <sub>OUT</sub> 11/54	69	HV <sub>OUT</sub> 47/18
30	HV <sub>OUT</sub> 12/53	70	HV <sub>OUT</sub> 48/17
31	HV <sub>OUT</sub> 13/52	71	HV <sub>OUT</sub> 49/16
32	HV <sub>OUT</sub> 14/51	72	HV <sub>OUT</sub> 50/15
33	HV <sub>OUT</sub> 15/50	73	HV <sub>OUT</sub> 51/14
34	HV <sub>OUT</sub> 16/49	74	HV <sub>OUT</sub> 52/13
35	HV <sub>OUT</sub> 17/48	75	HV <sub>OUT</sub> 53/12
36	HV <sub>OUT</sub> 18/47	76	HV <sub>OUT</sub> 54/11
37	HV <sub>OUT</sub> 19/46	77	HV <sub>OUT</sub> 55/10
38	HV <sub>OUT</sub> 20/45	78	HV <sub>OUT</sub> 56/9
39	HV <sub>OUT</sub> 21/44	79	HV <sub>OUT</sub> 57/8
40	HV <sub>OUT</sub> 22/43	80	HV <sub>OUT</sub> 58/7

# Package Outline

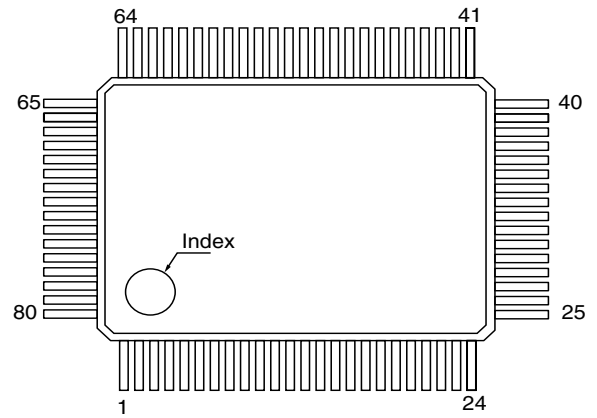

top view

80-pin Gullwing Package

#### Note:

Pin designation DIR = H/L

Example: For DIR = H, Pin 3 is HV<sub>OUT</sub> 59

For DIR = L, Pin 3 is HV<sub>OUT</sub> 6