

32-Channel Serial To Parallel Converter With Open Drain Outputs

Ordering Information

Device	Recommended Operating V_{PP} max	Package Options			
		44 J-Lead Quad Ceramic Chip Carrier	44 J-Lead Quad Plastic Chip Carrier	44 Lead Quad Plastic Gullwing	Die
HV5522	220V	HV5522DJ	HV5522PJ	HV5522PG	HV5522X
HV5530	300V	HV5530DJ	HV5530PJ	HV5530PG	HV5530X
HV5622	220V	HV5622DJ	HV5622PJ	HV5622PG	HV5622X
HV5630	300V	HV5630DJ	HV5630PJ	HV5630PG	HV5630X

Features

- Processed with HVCMOS® technology
- Sink current minimum 100mA
- Shift register speed 8MHz
- Polarity and Blanking inputs
- CMOS compatible inputs
- Forward and reverse shifting options
- Diode to V_{PP} allows efficient power recovery
- 44-lead ceramic surface mount package
- Hi-Rel processing available

Absolute Maximum Ratings

Supply voltage, V_{DD} ¹	-0.5V to +15V	
Output voltage, V_{PP} ¹	HV5530/HV5630	-0.5V to +315V
	HV5522/HV5622	-0.5V to +230V
Logic input levels ¹	-0.5V to $V_{DD} + 0.5V$	
Ground current ²	1.5A	
Continuous total power dissipation ³	Ceramic	1500mW
	Plastic	1200mW
Operating temperature range	Ceramic	-55°C to +125°C
	Plastic	-40°C to +85°C
Storage temperature range	-65°C to +150°C	
Lead temperature 1.6mm (1/16 inch) from case for 10 seconds	260°C	

Notes:

1. All voltages are referenced to V_{SS} .
2. Duty cycle is limited by the total power dissipated in the package.
3. For operation above 25°C ambient derate linearly to maximum operating temperature at 20°C for plastic and at 15mW/°C for ceramic.

General Description

The HV55 and HV56 are low-voltage serial to high-voltage parallel converters with open drain outputs. These devices have been designed for use as drivers for AC-electroluminescent displays. They can also be used in any application requiring multiple output high voltage current sinking capabilities such as driving inkjet and electrostatic print heads, plasma panels, vacuum fluorescent, or large matrix LCD displays.

These devices consist of a 32-bit shift register, 32 latches, and control logic to perform the polarity select and blanking of the outputs. Data is shifted through the shift register on the high to low transition of the clock. The HV55 shifts in the counterclockwise direction when viewed from the top of the package, and the HV56 shifts in the clockwise direction. A data output buffer is provided for cascading devices. This output reflects the current status of the last bit of the shift register. Operation of the shift register is not affected by the \overline{LE} (latch enable), \overline{BL} (blanking), or the \overline{POL} (polarity) inputs. Transfer of data from the shift register to the latch occurs when the \overline{LE} (latch enable) input is high. The data in the latch is stored when \overline{LE} is low.

Electrical Characteristics (over recommended operating conditions unless noted)

DC Characteristics

Symbol	Parameter	Min	Max	Units	Conditions	
I_{DD}	V_{DD} supply current		15	mA	$f_{CLK} = 8\text{MHz}$ $F_{DATA} = 4\text{MHz}$	
I_{DDQ}	Quiescent V_{DD} supply current		100	μA	$V_{IN} = 0\text{V}$	
$I_{O(OFF)}$	Off state output current		10	μA	All outputs high All SWS parallel	
I_{IH}	High-level logic input current		1	μA	$V_{IH} = V_{DD}$	
I_{IL}	Low-level logic input current		-1	μA	$V_{IL} = 0\text{V}$	
V_{OH}	High-level output data out	$V_{DD} - 1.0\text{V}$		V	$I_{Dout} = -100\mu\text{A}$	
V_{OL}	Low-level output voltage	HV _{OUT}		15.0	V	$I_{HVout} = +100\text{mA}$
		Data out		1.0	V	$I_{Dout} = +100\mu\text{A}$
V_{OC}	HV _{OUT} clamp voltage		-1.5	V	$I_{OL} = -100\text{mA}$	

AC Characteristics ($V_{DD} = 12\text{V}$, $T_C = 25^\circ\text{C}$)

Symbol	Parameter	Min	Max	Units	Conditions
f_{CLK}	Clock frequency		8	MHz	
t_W	Clock width high or low	62		ns	
t_{SU}	Data set-up time before clock falls	25		ns	
t_H	Data hold time after clock falls	10		ns	
t_{ON}	Turn on time, HV _{OUT} from enable		500	ns	$R_L = 2\text{K}\Omega$ to V_{PP} MAX
t_{DHL}	Delay time clock to data high to low		100	ns	$C_L = 15\text{pF}$
t_{DLH}	Delay time clock to data low to high		100	ns	$C_L = 15\text{pF}$
t_{DLE}	Delay time clock to $\overline{\text{LE}}$ low to high	50		ns	
t_{WLE}	Width of $\overline{\text{LE}}$ pulse	50		ns	
t_{SLE}	$\overline{\text{LE}}$ set-up time before clock falls	50		ns	

Recommended Operating Conditions

Symbol	Parameter	Min	Max	Units	
V_{DD}	Logic supply voltage	10.8	13.2	V	
HV_{OUT}	High voltage output	HV5530 and HV5630	-0.3	+300	V
		HV5522 and HV5622	-0.3	+220	V
V_{IH}	High-level input voltage	$V_{DD} - 2\text{V}$	V_{DD}	V	
V_{IL}	Low-level input voltage	0	2.0	V	
f_{CLK}	Clock frequency		8	MHz	
T_A	Operating free-air temperature	Plastic	-40	+85	$^\circ\text{C}$
		Ceramic	-55	+125	$^\circ\text{C}$

Input and Output Equivalent Circuits

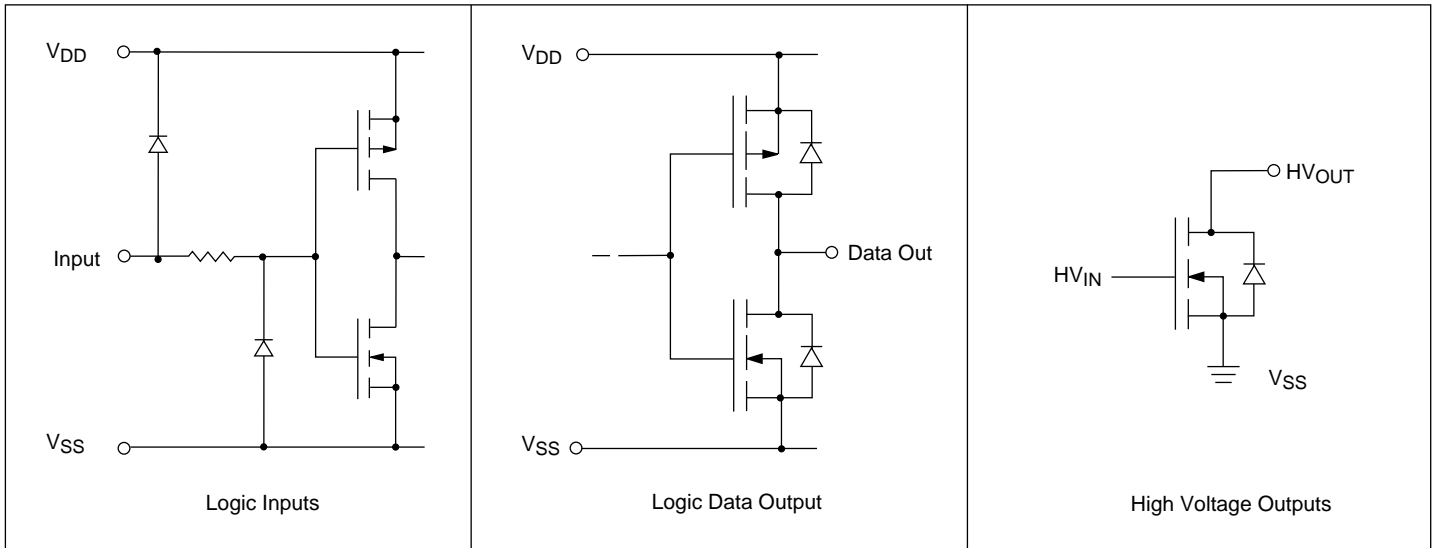

Switching Waveforms

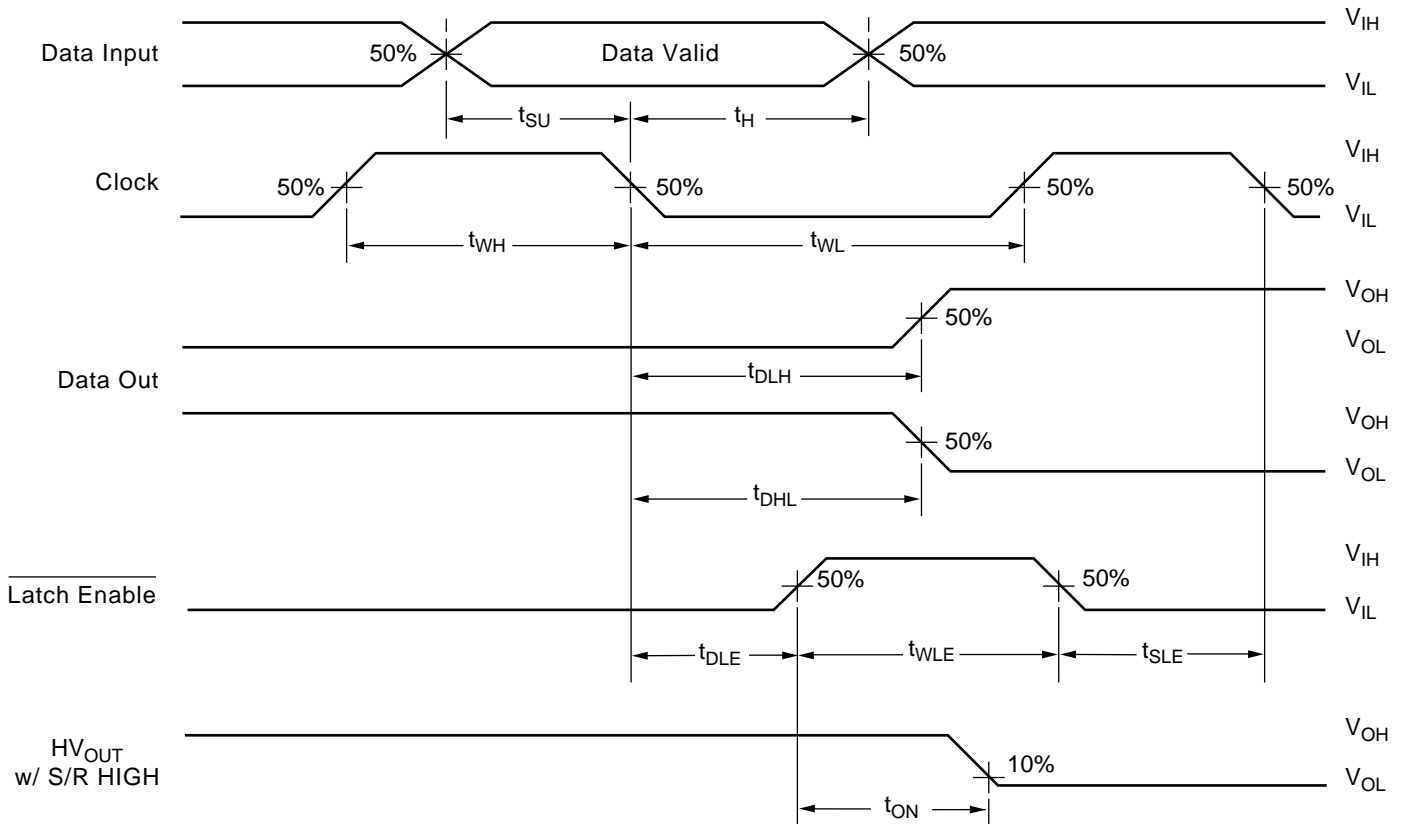

Functional Block Diagram

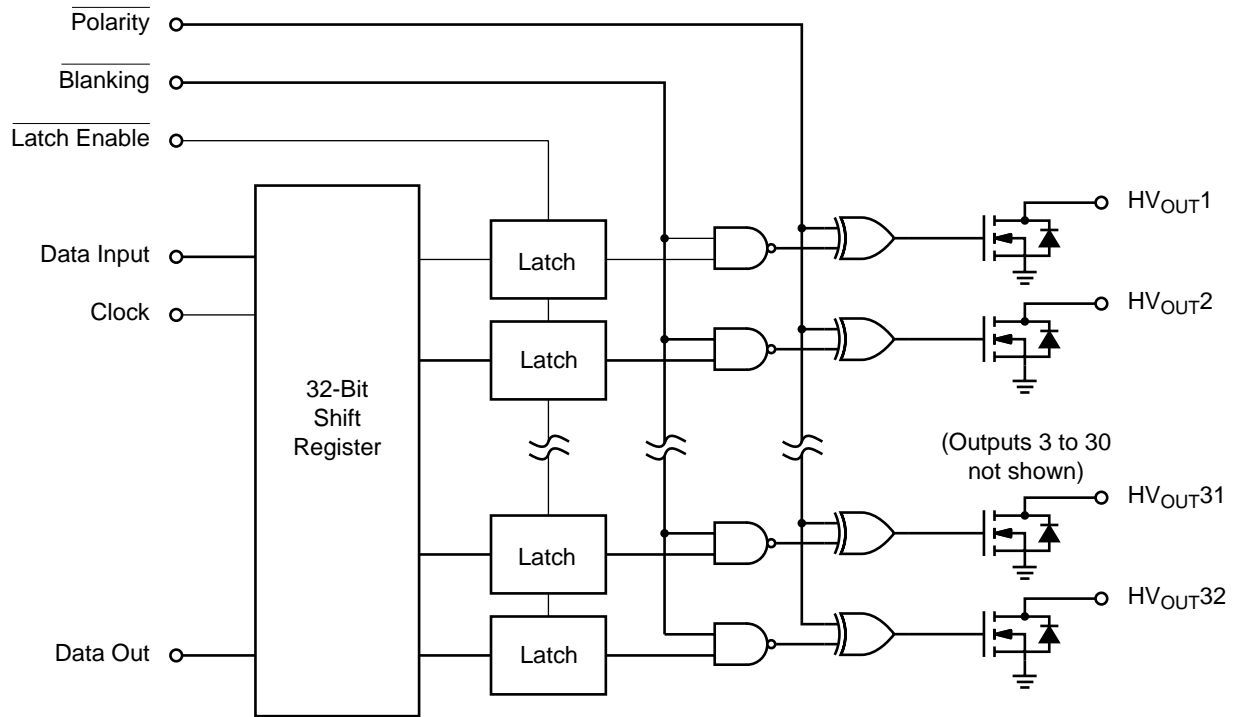

Function Table

Function	Inputs					Outputs		
	Data	CLK	\overline{LE}	\overline{BL}	\overline{POL}	Shift Reg 1 2...32	HV Outputs 1 2...32	Data Out *
All on	X	X	X	L	L	* ...*	On On...On	*
All off	X	X	X	L	H	* ...*	Off Off...Off	*
Invert mode	X	X	L	H	L	* ...*	$\overline{*}$ $\overline{*}$...	*
Load S/R	H or L	↓	L	H	H	H or L *...*	* ...*	*
Load Latches	X	H or L	↑	H	H	* ...*	* ...*	*
	X	H or L	↑	H	L	* ...*	$\overline{*}$ $\overline{*}$...	*
Transparent Latch mode	L	↓	H	H	H	L *...*	Off *...*	*
	H	↓	H	H	H	H *...*	On *...*	*

Notes:
H = high level, L = low level, X = irrelevant, ↓ = high-to-low transition, ↑ = low-to-high transition.
* = dependent on previous stage's state before the last CLK ↓ or last LE high.

Pin Configurations

Package Outline

HV55

44 Pin J-Lead Package

Pin	Function	Pin	Function
1	HV _{OUT} 16	23	Clock
2	HV _{OUT} 17	24	V _{SS}
3	HV _{OUT} 18	25	V _{DD}
4	HV _{OUT} 19	26	Latch Enable
5	HV _{OUT} 20	27	Data In
6	HV _{OUT} 21	28	Blanking
7	HV _{OUT} 22	29	N/C
8	HV _{OUT} 23	30	HV _{OUT} 1
9	HV _{OUT} 24	31	HV _{OUT} 2
10	HV _{OUT} 25	32	HV _{OUT} 3
11	HV _{OUT} 26	33	HV _{OUT} 4
12	HV _{OUT} 27	34	HV _{OUT} 5
13	HV _{OUT} 28	35	HV _{OUT} 6
14	HV _{OUT} 29	36	HV _{OUT} 7
15	HV _{OUT} 30	37	HV _{OUT} 8
16	HV _{OUT} 31	38	HV _{OUT} 9
17	HV _{OUT} 32	39	HV _{OUT} 10
18	Data Out	40	HV _{OUT} 11
19	N/C	41	HV _{OUT} 12
20	N/C	42	HV _{OUT} 13
21	N/C	43	HV _{OUT} 14
22	Polarity	44	HV _{OUT} 15

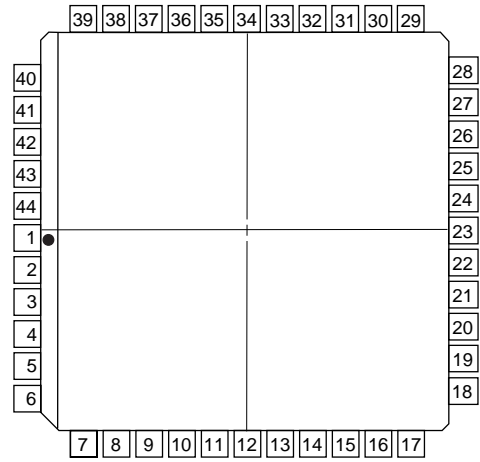

top view
44-pin J-Lead Package

HV56

44 Pin J-Lead Package

Pin	Function	Pin	Function
1	HV _{OUT} 17	23	Clock
2	HV _{OUT} 16	24	V _{SS}
3	HV _{OUT} 15	25	V _{DD}
4	HV _{OUT} 14	26	Latch Enable
5	HV _{OUT} 13	27	Data In
6	HV _{OUT} 12	28	Blanking
7	HV _{OUT} 11	29	N/C
8	HV _{OUT} 10	30	HV _{OUT} 32
9	HV _{OUT} 9	31	HV _{OUT} 31
10	HV _{OUT} 8	32	HV _{OUT} 30
11	HV _{OUT} 7	33	HV _{OUT} 29
12	HV _{OUT} 6	34	HV _{OUT} 28
13	HV _{OUT} 5	35	HV _{OUT} 27
14	HV _{OUT} 4	36	HV _{OUT} 26
15	HV _{OUT} 3	37	HV _{OUT} 25
16	HV _{OUT} 2	38	HV _{OUT} 24
17	HV _{OUT} 1	39	HV _{OUT} 23
18	Data Out	40	HV _{OUT} 22
19	N/C	41	HV _{OUT} 21
20	N/C	42	HV _{OUT} 20
21	N/C	43	HV _{OUT} 19
22	Polarity	44	HV _{OUT} 18

Pin Configurations

HV55

44-Pin Quad Plastic Gullwing Package

Pin	Function	Pin	Function
1	HV _{OUT} 11	23	Data Out
2	HV _{OUT} 12	24	N/C
3	HV _{OUT} 13	25	N/C
4	HV _{OUT} 14	26	N/C
5	HV _{OUT} 15	27	Polarity
6	HV _{OUT} 16	28	Clock
7	HV _{OUT} 17	29	V _{SS}
8	HV _{OUT} 18	30	V _{DD}
9	HV _{OUT} 19	31	Latch Enable
10	HV _{OUT} 20	32	Data In
11	HV _{OUT} 21	33	Blanking
12	HV _{OUT} 22	34	N/C
13	HV _{OUT} 23	35	HV _{OUT} 1
14	HV _{OUT} 24	36	HV _{OUT} 2
15	HV _{OUT} 25	37	HV _{OUT} 3
16	HV _{OUT} 26	38	HV _{OUT} 4
17	HV _{OUT} 27	39	HV _{OUT} 5
18	HV _{OUT} 28	40	HV _{OUT} 6
19	HV _{OUT} 29	41	HV _{OUT} 7
20	HV _{OUT} 30	42	HV _{OUT} 8
21	HV _{OUT} 31	43	HV _{OUT} 9
22	HV _{OUT} 32	44	HV _{OUT} 10

Package Outline

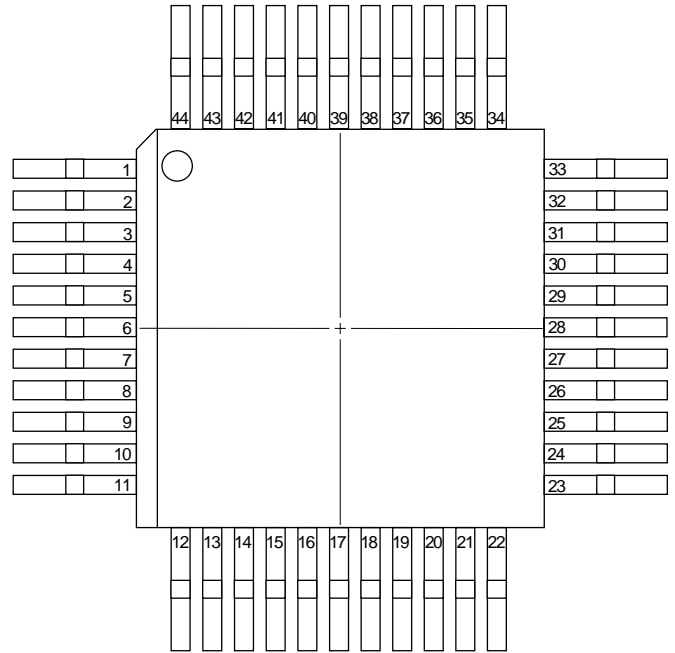

top view
44-pin Quad Plastic Gullwing Package

HV56

44-Pin Quad Plastic Gullwing Package

Pin	Function	Pin	Function
1	HV _{OUT} 22	23	Data Out
2	HV _{OUT} 21	24	N/C
3	HV _{OUT} 20	25	N/C
4	HV _{OUT} 19	26	N/C
5	HV _{OUT} 18	27	Polarity
6	HV _{OUT} 17	28	Clock
7	HV _{OUT} 16	29	V _{SS}
8	HV _{OUT} 15	30	V _{DD}
9	HV _{OUT} 14	31	Latch Enable
10	HV _{OUT} 13	32	Data In
11	HV _{OUT} 12	33	Blanking
12	HV _{OUT} 11	34	N/C
13	HV _{OUT} 10	35	HV _{OUT} 32
14	HV _{OUT} 9	36	HV _{OUT} 31
15	HV _{OUT} 8	37	HV _{OUT} 30
16	HV _{OUT} 7	38	HV _{OUT} 29
17	HV _{OUT} 6	39	HV _{OUT} 28
18	HV _{OUT} 5	40	HV _{OUT} 27
19	HV _{OUT} 4	41	HV _{OUT} 26
20	HV _{OUT} 3	42	HV _{OUT} 25
21	HV _{OUT} 2	43	HV _{OUT} 24
22	HV _{OUT} 1	44	HV _{OUT} 23