

Demo Board Available!

White LED Driver

Features

- Power efficiency of up to 85%
- Drives up to 6 White LEDs
- 2.6V to 4.6V Supply power stage can operate at 1.8V (see page 8)
- Built-in Soft Start
- DC and PWM Dimming Control
- Built-in Open LED protection
- Open LED indicator (via R_{SET})
- 1.2MHz Fixed Switching Frequency
- 500nA max leakage current when disabled
- No leakage current path through LEDs when disabled
- Resistor-programmable LED Current
- Small 6-lead MLP (3mm x 3mm) package (similar to 6-pin SOT-23)

Applications

- Color LCD Backlighting
- Cell phones, smart phones
- PDAs, pocket PCs
- Organizers
- Digital Cameras
- MP3 Players

Typical Application

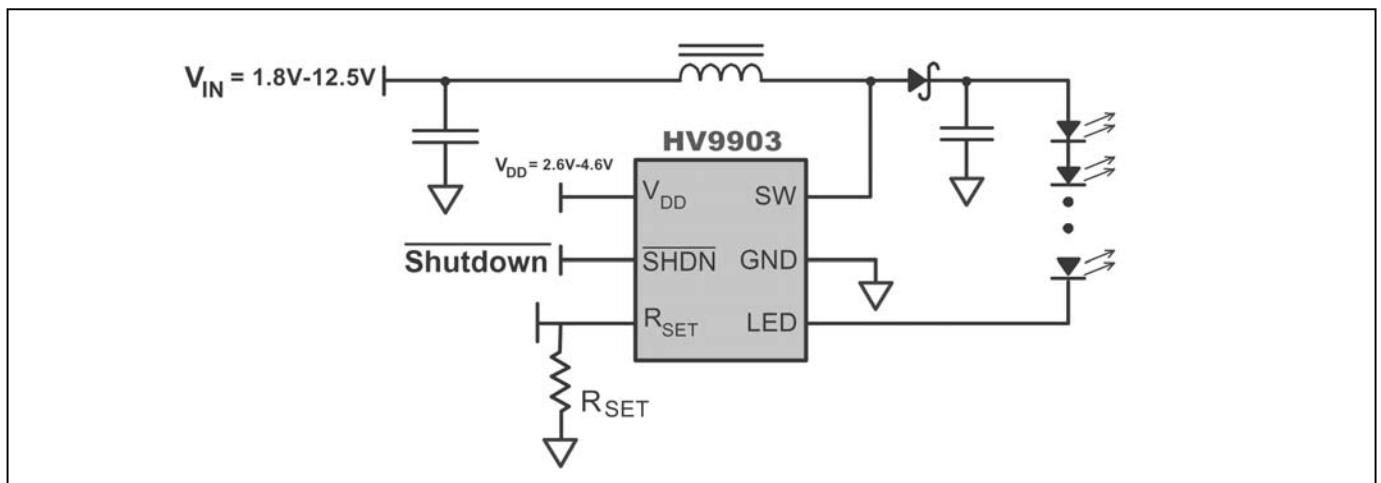

Description

The Supertex HV9903 is a fixed frequency DC-DC boost converter designed for driving Light Emitting Diodes (LEDs) with constant current where the light intensity is proportional to the current through them. The input supply voltage range into the device (V_{DD}) is 2.6 to 4.6V. Operation of the driver at lower voltages is possible as long as a 2.6–4.6V low-current supply is available for the HV9903. The device uses a single inductor and a minimum number of passive components. The device can be enabled/disabled via the SHDN pin.

The HV9903 has an internal oscillator. The oscillator frequency is at fixed frequency of 1.2MHz that allows use of small value inductors. The LED current can be adjusted from 5 to 40mA by an external resistor connected between the R_{SET} and the GND pins. The amount of current though the LED can also be adjusted via DC voltage or a pulse width modulated (PWM) signal to the R_{SET} pin.

Soft-start is implemented on-chip, minimizing inrush current to only 30% over steady state current.

An open LED circuit detects an open LED condition, disables the driver, and sets the R_{SET} pin high. The driver is re-enabled by asserting SHDN low, then high. If the open LED condition persists, the driver will again latch off.

Ordering Information

Device	Package Option	Demo Kit
	MLP (3mm x 3mm)	
HV9903	HV9903K6*	HV9903DB1

*Product supplied on 3000 piece carrier tape reels

Absolute Maximum Ratings

V_{DD}	6V
V_{SW} , SW Voltage	+35V
V_{SHDN}	-0.5V to 6V
I_{Rset}	10mA
V_{Rset}	$V_{DD} + 0.5V$
Storage Temperature	-65°C to +150°C
Operating Temperature	-40°C to +85°C

Recommended Operating Conditions

Symbol	Parameter	Min	Typ	Max	Unit	Conditions
V_{DD}	Supply voltage	2.6		4.6	V	
$I_{SW(pk)}$	Peak switch current			600	mA	
T_{AMB}	Operating temperature	-40		85	°C	
I_{LED}	LED current	5		40	mA	

Specifications (unless otherwise specified: $T_A = 25^\circ\text{C}$, $V_{DD} = 2.6V$)

Symbol	Parameter	Min	Typ.	Max	Unit	Conditions
OVP	Over voltage protection	28	33	35	V	
I_{DD}	V_{DD} supply current			1.6	mA	$V_{Rset} = 0.2V$
I_{DDQ}	Total leakage current when disabled ($I_{SW(off)} + I_{DD(off)} + I_{LED(off)}$)			500	nA	$V_{SHDN} = 0V$, $R_{SET} = 1.5K\Omega$
R_{SW}	Switch on resistance		0.6	1.0	Ω	$V_{DD} = 2.7V$
$I_{SW(lim)}$	Switch current limit		900		mA	
V_{Rset}	Rset pin voltage		100		mV	$R_{SET} = 1.5K\Omega$
V_{LED}	LED pin voltage			180	mV	$R_{SET} = 1.5K\Omega$, $V_{DD} < V_{OUT}$
I_{LED}	LED pin current		5		mA	$R_{SET} = 4.53K\Omega$
		12.5	15	17.5		$R_{SET} = 1.5K\Omega$
		17	20	23		$R_{SET} = 1.13K\Omega$
		25	30	36		$R_{SET} = 750\Omega$
		33	38	45		$R_{SET} = 562\Omega$
TC	I_{LED} Tempco		0.02		mA/°C	$I_{LED} = 15mA$

Symbol	Parameter	Min	Typ.	Max	Unit	Conditions
I_{SHDN}	SHDN input current			-100	nA	$V_{SHDN} = 0V$
				100		$V_{SHDN} = 2V$
f_{SW}	Inductor switching frequency	0.8	1.2	1.6	MHz	$V_{DD} = 2.6$ to $4.6V$
D_{MAX}	Maximum duty cycle	90	95		%	
V_{IL}	IC Shutdown voltage (SHDN pin), Off			0.9	V	
V_{IH}	IC Start-up voltage (SHDN pin), On	1.2				
V_{Open}	Open LED indicator at R_{SET} lead	2.0	$V_{DD} - 0.4V$	V_{DD}	V	$V_{OUT} > 33V$, $R_{SET} = 562\Omega$, $V_{DD} = 2.7V$
$I_{SW(off)}$	Switch Off leakage current			100	nA	$V_{SW} = 5V$

Pin Configuration

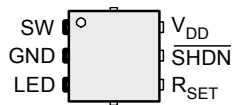

Top View

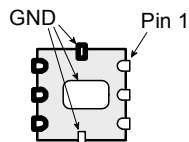

Bottom View

Pin	Name	Description
1	SW	Internal switch connection.
2	GND	Ground. The underside pads are internally connected to pin 2.
3	LED	Cathodes of the LEDs are connected to this pin.
4	R_{SET}	For programming the LED current and dimming function. Also functions as a Fault output to indicate an open LED condition. R_{SET} is pulled to V_{DD} when an open LED condition is detected. The driver is then latched off. To reset, the SHDN input must be asserted low. An externally applied voltage greater than 100mV causes the LED switch and PWM boost converter to shut off. The IC does not go into low power standby and the soft-start circuit is not reactivated when V_{Rset} again falls below 100mV.
5	SHDN	Shut down input. A logic low disables the IC and places it in low power standby. A logic high enables the IC via a soft-start sequence.
6	V_{DD}	Input voltage supply pin. It is common practice to use a bypass capacitor as close as possible to the device on this pin.

Functional Block Diagram

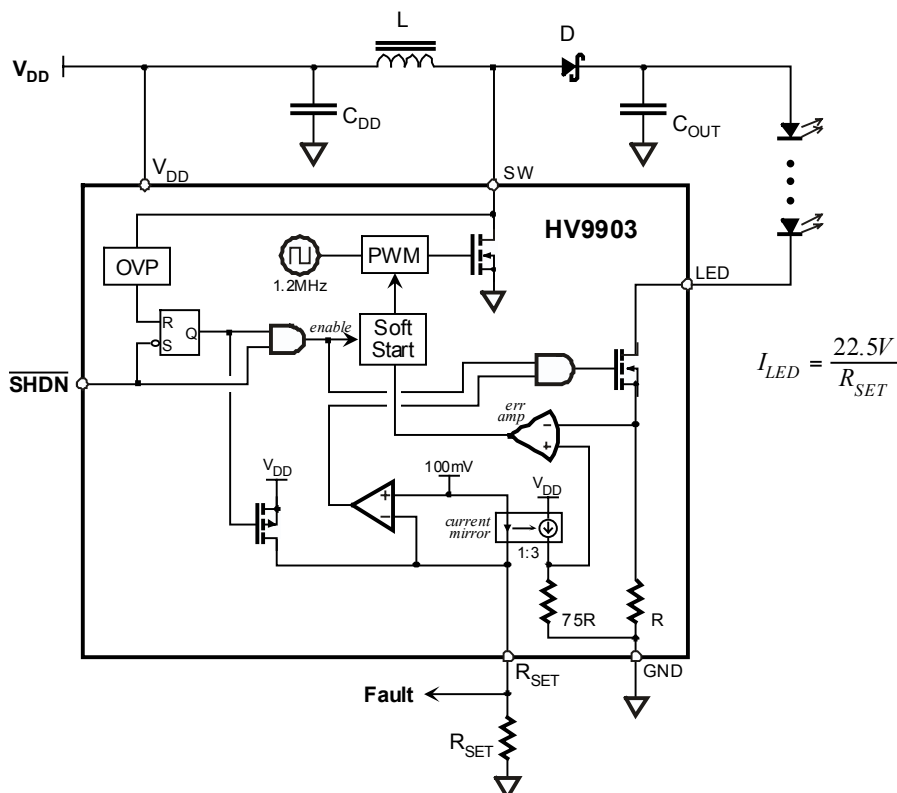

Note: This drawing is a generalized representation of the HV9903. Actual internal circuitry may differ.

Operation

The HV9903 operates as a boost converter that regulates output current rather than output voltage. To maintain constant output current, LED current is monitored via the LED pin and the boost converter's PWM duty cycle is adjusted accordingly to maintain the desired current level. LED current is controlled 100% via the PWM boost converter – the MOSFET connected to the LED pin is fully turned on during normal operation and is not regulated to maintain constant LED current. This minimizes voltage drop at the LED pin, maximizing overall efficiency.

LED current is set by the value of the resistor connected to the R_{SET} pin. The voltage at the R_{SET} pin is maintained at 100mV and the resulting current through the R_{SET} resistor is used as a reference for LED current control. LED current is regulated at 225 times R_{SET} current.

$$I_{LED} = \frac{22.5V}{R_{SET}}$$

Current through the R_{SET} pin is monitored. If it falls below 1.5µA, both the PWM boost converter switch

and LED switch are turned off. Soft-start is not reset and the IC does not go into low power standby. Such a condition can occur two ways: 1) if R_{SET} is greater than about 66kΩ, or 2) an external voltage greater than 100mV is applied to the R_{SET} pin. Internal blocking prevents reverse current flow into the R_{SET} pin if the externally applied voltage exceeds 100mV. However, applied voltage must not exceed V_{DD}.

The control loop is designed for discontinuous mode operation. That is, inductor current is allowed to return to zero between PWM conversion cycles. To assure discontinuous mode operation, the inductor value must be below a certain value for given conditions of supply voltage and LED string voltage drop. The Inductor Selection section provides further information.

The PWM boost converter is a current mode controller operating at an internally fixed 1.2MHz.

A soft-start circuit minimizes inrush current when power is initially applied or the device is enabled via the SHDN input. Inrush current is typically limited to 130% of steady-state current. Although the soft-start period is short (~1ms), it means that if using SHDN for PWM dimming, the PWM dimming signal should be

fairly low frequency so that the 1ms soft-start interval does not introduce much error. The R_{SET} input is better for PWM dimming, as it does not include soft-start. (See below for PWM dimming techniques.)

Soft Start

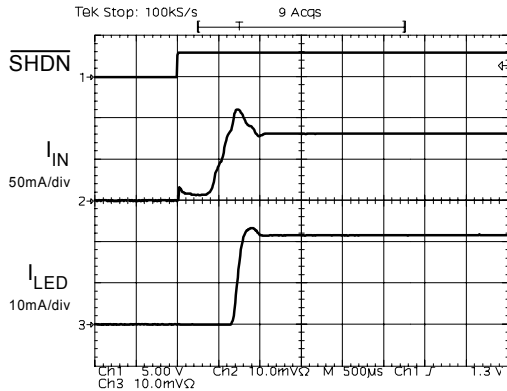

Open LED Protection

Open LED protection is integrated into the HV9903. Without open LED protection, output voltage would climb to destructive levels as the driver attempts to correct for the open LED condition.

Should the voltage at the SW pin exceed 33V, the driver latches off and the R_{SET} pin is pulled to V_{DD} , indicating a fault condition. To reset the latch, assert SHDN low for at least 200ns. When SHDN is again brought high, the driver will be re-enabled, including soft-start. If the open LED condition persists, the HV9903 will again latch off.

Inductor Selection

The HV9903 is designed for discontinuous mode operation. Control loop stability may be compromised if the converter is allowed to operate in continuous mode. To assure discontinuous mode operation, the inductor must not exceed a certain value depending on supply voltage, output current, and output voltage. The following graphs show the maximum permissible inductor value and inductor current rating for a lithium-ion battery application (2.7V minimum battery voltage). When calculating LED string voltage drop, use maximum LED voltage. If using paralleled LED strings with current balancing resistors, include the resistor voltage drop in $V_{LED-STRING}$. V_D is the diode's forward voltage drop. Always select the next lower standard value inductor and be conservative on

inductor rating. Choosing an inductor with lower resistance results in more efficient operation.

Inductor Value for 2.7V Operation

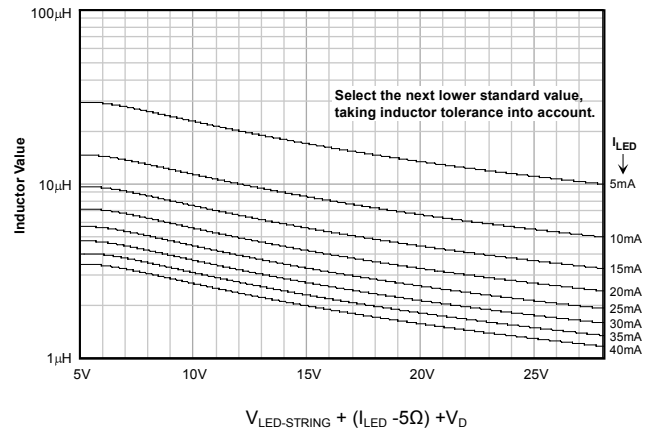

Inductor Rating for 2.7V Operation

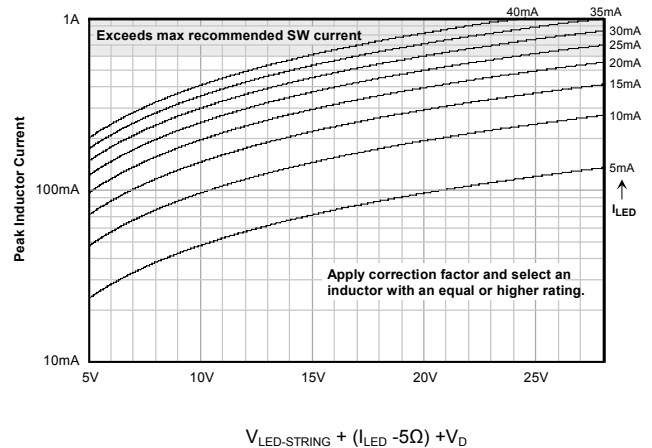

When selecting the next lower standard value inductor, the current rating must be adjusted according to the following equation.

$$I_{CORRECTED} = I_{GRAPH} \frac{L_{GRAPH}}{L_{SELECTED}}$$

As an example, 4 LEDs with 4V max drop are to be driven at 20mA. LED string drop is 16V plus 0.6V for the diode plus 0.1V for LED pin voltage, for a total of 16.7 volts. From the graphs, inductor value at 16.7V and 20mA is 3.7µH and rating is 320mA. The next

lower standard value is 3.3μH (10% tolerance) and the corrected rating is then:

$$I_{CORRECTED} = 320\text{mA} \frac{3.7\mu\text{H}}{3.3\mu\text{H}} = 359\text{mA}$$

Inductor data sheets may rate the inductor in terms of DC current, RMS current, or saturation current. The DC or saturation ratings should be used. Confirm that the inductor is not saturating by observing the SW pin. When an inductor saturates, current begins to climb rapidly. This condition is evidenced by a breakpoint in the SW voltage waveform as indicated in the diagram below. Normally, the voltage at the SW pin should be a fairly linear ramp, as the linear rise in inductor current through the SW resistance produces a linear voltage ramp. When the inductor saturates, the rapid rise in current produces a likewise rapid rise in SW voltage. Test using an HV9903 with a low switching frequency.

SW Waveform Showing Inductor Saturation

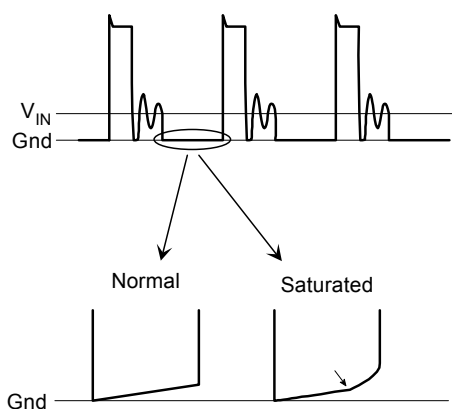

Note: ringing or noise may be present.

Also, confirm that the driver is operating in discontinuous mode by observing the voltage at the SW pin while at minimum supply and maximum LED current. For worst-case test purposes, select components within their tolerance range as follows:

- Inductor: high value
- LED: high voltage drop
- HV9903: high switching frequency

Some ringing in the SW waveform will be evident, but is not a concern as the energy is very low. About 10-15% idle time should be allowed to assure discontinuous mode operation. Idle time is the interval when there is no inductor current flowing, as

indicated when the SW voltage is at the supply voltage level (with some ringing).

The following graphs show the SW waveform with various inductor values and can assist in selecting an inductor. The top graph shows an inductor value that is acceptable, however, greater efficiency can be achieved by increasing inductance. The bottom graph shows continuous mode operation, which must be avoided.

SW Waveform with Various Inductor Values

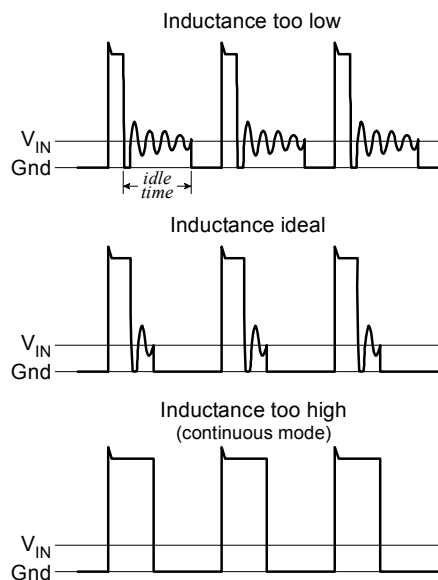

Capacitor Selection

Proper selection of C_{DD} and C_{OUT} is essential to the efficient operation of the LED driver. Both C_{DD} and C_{OUT} should be around 1μF with good high frequency characteristics (low ESR and ESL). Ceramic capacitors are a practical choice for their high volumetric efficiency and good high frequency characteristics, but pay attention to the capacitor's voltage coefficient. Some small, high value ceramic capacitors can lose 75% of their capacitance at their rated voltage! X5R, Y5V, and Z5U formulations are more susceptible to this effect, as well as possessing higher temperature coefficients. X7R formulations are a better choice.

The voltage rating of C_{DD} should be greater than the maximum supply voltage. To be compatible with the HV9903's open LED protection, C_{OUT}'s voltage rating should be 35V or more.

Diode Selection

Since the HV9903 operates at a 1.2MHz switching frequency, the output rectifier must be fast – 20ns or less. The faster the diode, the more efficiently the driver operates. Also, choose a diode with low capacitance to improve performance. A Schottkey need not be used, although its lower forward voltage drop improves efficiency. Peak current rating is the same as for the inductor. Average current is simply the LED current. To be compatible with the HV9903’s open LED protection, the diode’s reverse voltage rating should be 35V or more. Otherwise, the diode’s voltage rating should be greater than the LED string’s voltage drop plus 1 volt.

Dimming

Dimming may be accomplished in one of two ways: DC dimming or PWM dimming. DC dimming linearly regulates the current through the LEDs in a continuous fashion, while PWM dimming rapidly turns the LEDs on and off while maintaining a constant ‘on’ current. In PWM dimming, the ratio of on to off time determines perceived brightness. The on/off frequency must be high enough to prevent visible flickering – typically above 70Hz. The claimed advantage of PWM dimming is less color shift as the LED is dimmed, although the effect is virtually imperceptible.

DC dimming is accomplished by applying a bias to the R_{SET} resistor.

DC Dimming

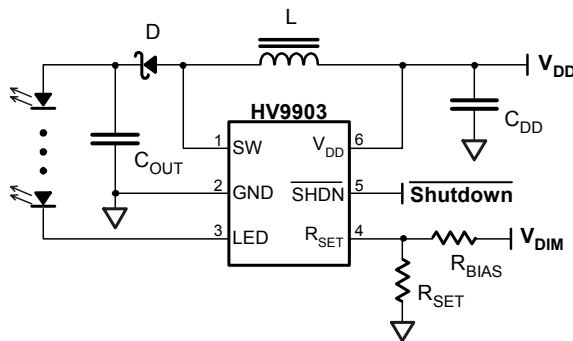

$$I_{LED} = 225 \left(\frac{100\text{mV}}{R_{SET}} - \frac{V_{DIM} - 100\text{mV}}{R_{BIAS}} \right)$$

DC Dimming Frequency Response

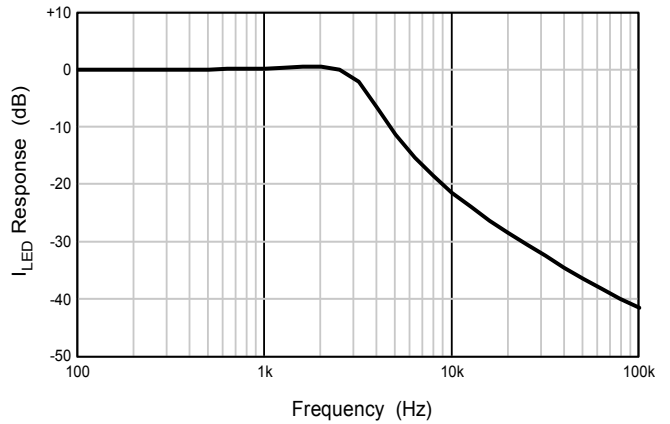

PWM dimming may be implemented via the SHDN input or via R_{SET}. Since SHDN reactivates soft-start, a delay is introduced (~1ms) to LED turn-on. For this reason, it is better to use the R_{SET} pin for PWM dimming, as it does not include the soft-start delay. PWM dimming frequency should be in the range of 70-100Hz to minimize the effect of turn-on delays while avoiding flicker.

PWM Dimming via SHDN

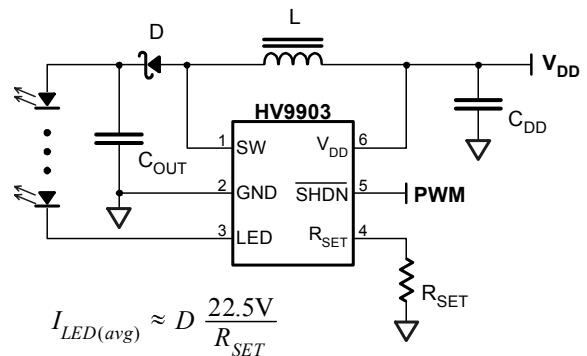

$$I_{LED(avg)} \approx D \frac{22.5V}{R_{SET}}$$

PWM Dimming via R_{SET}

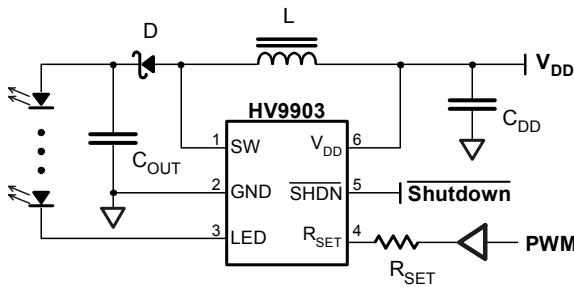

$$I_{LED(avg)} \approx (1-D) \frac{22.5V}{R_{SET}}$$

The logic signal must have a low output impedance relative to R_{SET} and be capable of going to within a few millivolts of ground. The following modification provides higher immunity to the logic low voltage level (V_{LO}). It also minimizes the effect of voltage differences between the HV9903's ground and the PWM signal source's ground.

PWM Dimming via R_{SET}

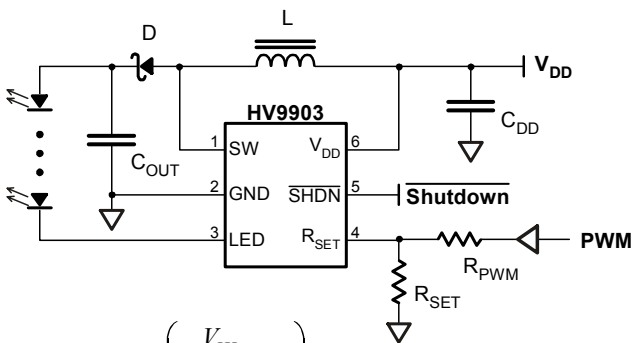

$$R_{PWM} < R_{SET} \left(\frac{V_{HI}}{100mV} - 1 \right)$$

$$I_{LED(avg)} \approx 225(1-D) \left(\frac{100mV}{R_{SET}} + \frac{100mV - V_{LO}}{R_{PWM}} \right)$$

DC dimming may be implemented in discrete steps using logic signals, as shown below.

Multi-level Logic Dimming

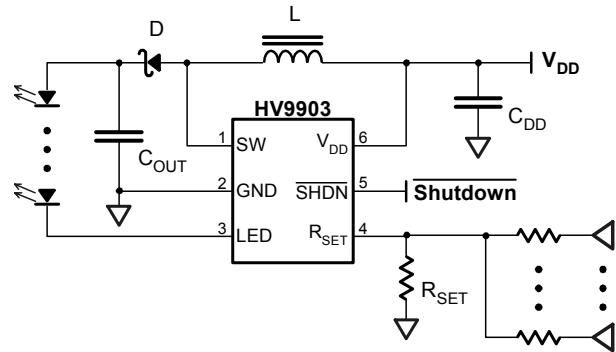

Dual-cell Alkaline Operation

The HV9903 LED driver may be used in 2-cell alkaline battery applications (1.8V min) by powering the power stage directly from the batteries, while powering the HV9903 from an available 3.3V supply. Supplying the power stage directly from the batteries reduces the load on the 3.3V supply, which in turn increases overall efficiency and keeps components small. The same dimming techniques used in the single-supply application may be used in this dual-supply application.

2-cell Alkaline Circuit

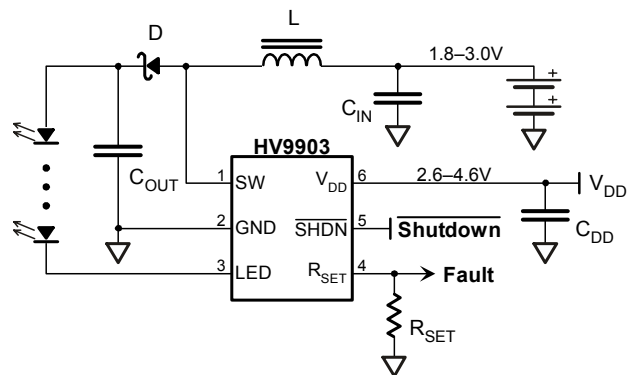

Component selection is similar to the Li-ion battery application with the exception of the inductor and C_{DD} capacitor. Since high current is no longer being drawn from V_{DD} , C_{DD} may be lowered to around 10nF. C_{IN} should be $1\mu F$. In selecting the inductor, use the following graphs.

Inductor Value for 1.8V Operation

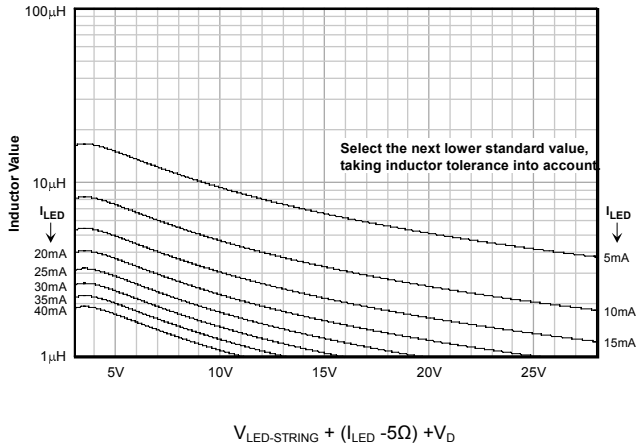

Inductor Rating for 1.8V Operation

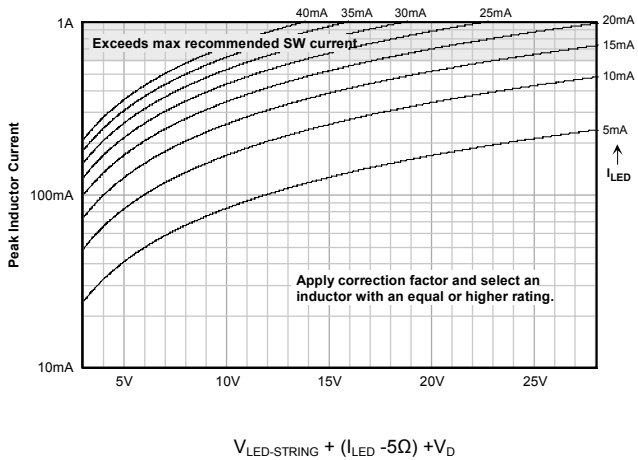

Don't forget to apply the correction factor and confirm that the inductor is not saturating and the driver is operating in discontinuous mode, as outlined earlier.

Board Layout

Since high frequencies are involved, PCB layout is critical. To minimize parasitic inductance and radiated EMI, the loop area of the high frequency paths must be kept to a minimum. Second, try to keep the two loop areas as concentric as possible. Lastly, make traces as short and wide as possible. To avoid LED current errors, keep the R_{SET} ground connection separate from high current ground paths and connect directly to pin 2.

The following schematic depicts the high frequency paths and their enclosed areas.

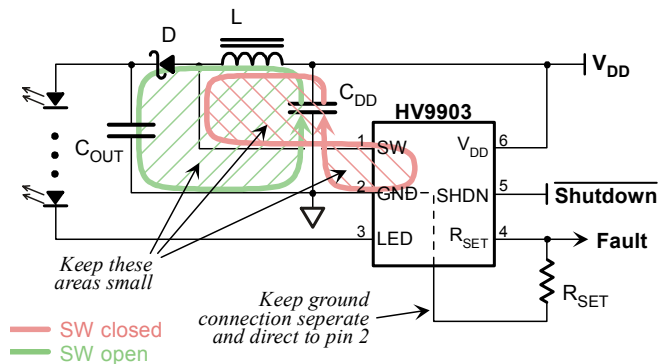

The following PCB layout is recommended.

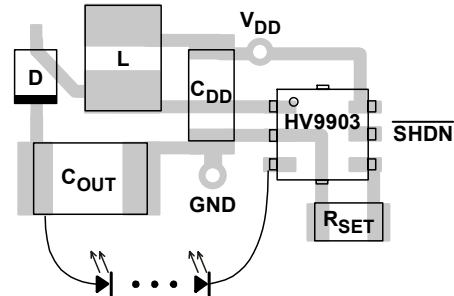

It is also good practice to run the LED's supply and return traces as close together as possible, reducing

the loop area of the LED path. Running the return trace on a separate layer directly underneath the supply trace would be the ideal layout.

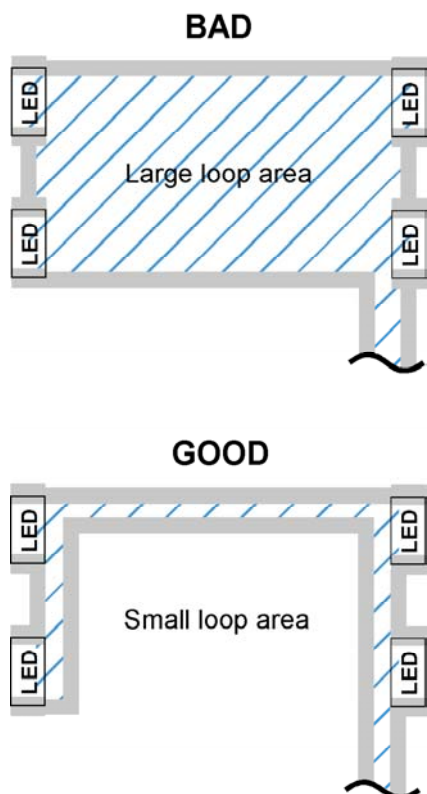

The 3 pads along the centerline on the underside of the HV9903 are internally connected to pin 2 and need not be connected externally to ground.

The HV9903's MLP package fits in most pad layouts designed for a 6-pin SOT-23.

Split Supply Operation

The HV9903 LED driver may be used in Split Supply application by powering the power stage directly from the batteries, while powering the HV9903 (V_{DD}) from an available regulated supply within 2.6V to 4.6V. The power stage voltage (V_{IN}) can be higher than 4.6V so long as the inductor is being operated in discontinuous mode.

Supplying the power stage directly from the batteries reduces the load on the regulated supply, which in turn increases overall efficiency and keeps components small. The same dimming techniques used in the single-supply application may be used in this dual-supply application.

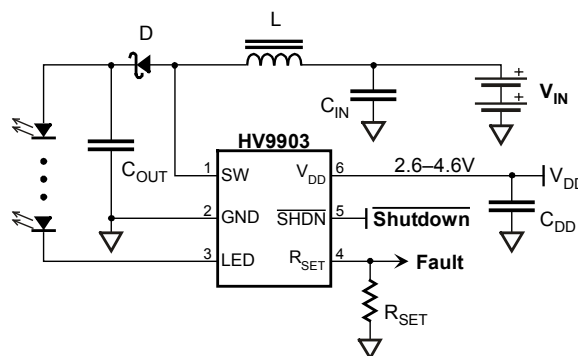

Typical Performance

C_{OUT} =Murata GRM32RR71H105KA01L, LEDs = Nichia NSPW500BS, D = Zetex ZHCS400 or ZHCS500

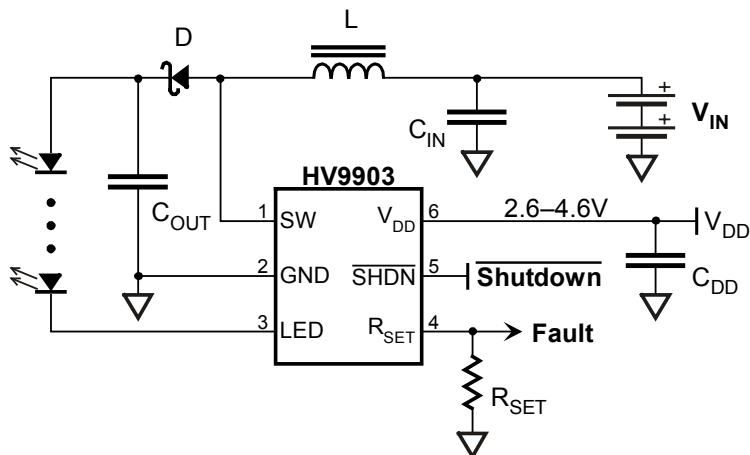

$V_{DD} = V_{IN}$	C_{IN}	L	R_{SET}	C_{OUT}	LEDs	I_{IN}	V_{OUT}	I_{LED}
3.3V	10.0 μ F	4.7 μ H, Murata LQH32CN4R7M11	1.5K Ω	1.0 μ F, 50V	4	78.5mA	13.1V	15.5mA
					6	111.2mA	19.4V	

Other Examples

C_{OUT} =Murata CRM32RR71H105KA01L, LEDs = Nichia NSPW500BS, D = Zetex ZHCS400 or ZHCS500

$V_{DD} = V_{IN}$	C_{IN}	L	R_{SET}	C_{OUT}	LEDs	I_{IN}	V_{OUT}	I_{LED}
3.3V	10.0 μ F	4.7 μ H, Murata LQH32CN4R7M11	1.0K Ω	1.0 μ F, 50V	4	111.3mA	13.6V	22.8mA
					6	166.9mA	19.9V	

V_{DD}	V_{IN}	C_{IN}	L	R_{SET}	C_{OUT}	LEDs	I_{IN}	V_{OUT}	I_{LED}
3.0V	1.8V	10.0 μ F	4.7 μ H, Murata LQH32CN4R7M11	1.5K Ω	1.0 μ F, 50V	4	154.8	13.0V	16.5mA
	6.0V						40.2mA		
	9.0V						26.1mA		
	6.0V					6	63.4mA	19.4V	
	9.0V						41.3mA		

$V_{DD} = V_{IN}$	C_{IN}	L	R_{SET}	C_{OUT}	LEDs	I_{IN}	V_{OUT}	I_{LED}
3.3V	10.0 μ F	10 μ H, Murata LQH2MC100K02	1.5K Ω	1.0 μ F, 50V	4	77.9mA	12.92V	16.8mA

6-LEAD MLP PACKAGE OUTLINE (K6) (3MM X 3MM)

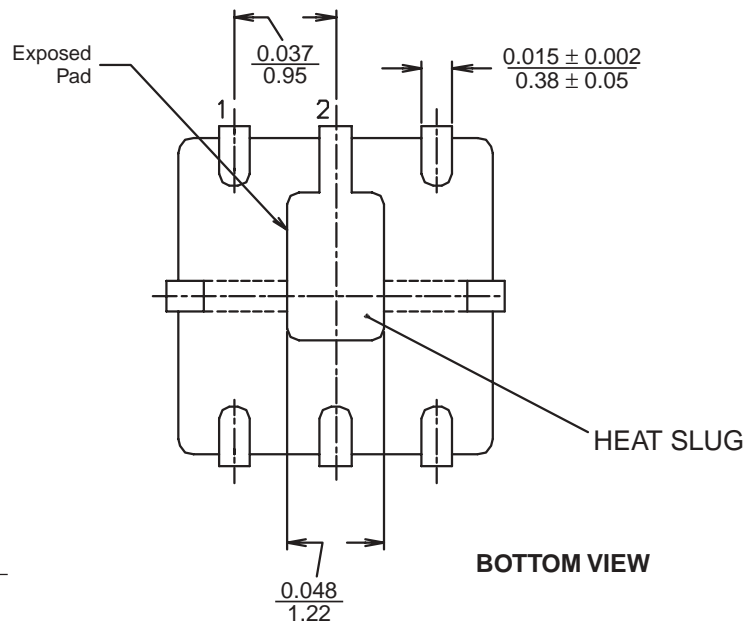
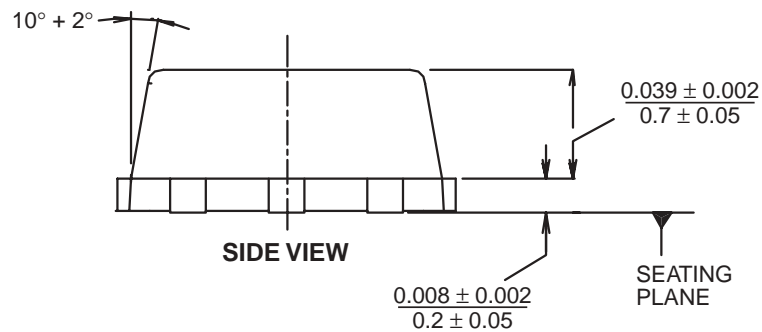
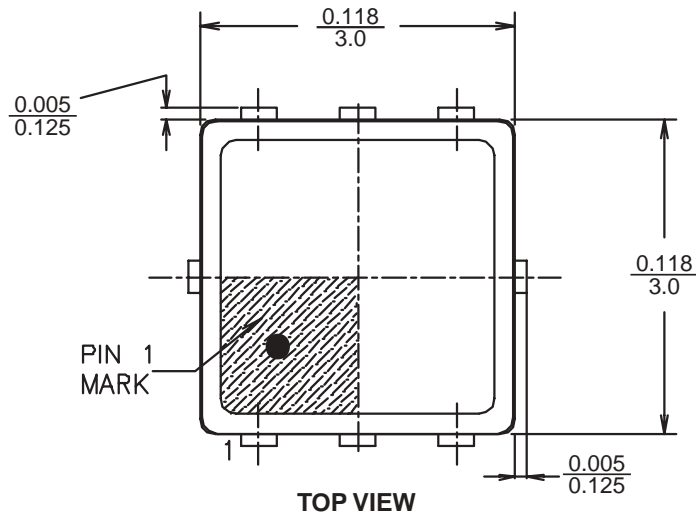

Measurement = $\frac{\text{Inches}}{\text{millimeters}}$