

8-BITS SINGLE MICROCONTROLLER with 16/32/64-Kbytes of FLASH, 256 byte +512 byte RAM

FEATURES

- 80C52 based architecture
- 256 Byte RAM internal RAM and 512 Bytes auxiliary RAM available
- Three 16-bit Timer/Counters
- Full duplex serial channel
- Boolean processor
- Power Save Mode :
 - 1) Idle Mode
 - 2) Power Down Mode - waken up from interrupt level trigger mode
- Program memory lock
 - Lock bits (3)
- Four 8-bit I/O ports, 32 I/O lines
- Memory addressing capability
 - 64K Program Memory and 64K Data Memory
- CMOS and TTL compatible
- Maximum speed ranges at Vcc = 5V is 40 MHz and most instructions execute in 0.3 μs
- Packages available:
 - 40-pin DIP
 - 44-pin PLCC
 - 44-pin PQFP
- 16K/32K/64K Byte Flash Memory with fast-pulse programming algorithm
- 36 I/O pins(above 44-pin package only)
- 8 interrupts vectors (above 44-pin package only)
- Low EMI mode

GENERAL DESCRIPTION

IC89E54, IC89E58, IC89E64 are members of ICSI embedded microcontroller family. The IC89E54/58/64 uses the same powerful instruction set, has the same architecture, and is pin-to-pin compatible with standard 80C51 controller devices. They have IC89E54/58/64 all functions and some enhanced function is included. These enhanced functions include 512 bytes auxiliary memory, 36 I/O pins (44 pin package only), 8 interrupts (44 pin package only) with two-level priority, Power off flag, Low EMI mode, power down mode is waken up from interrupt level trigger mode.

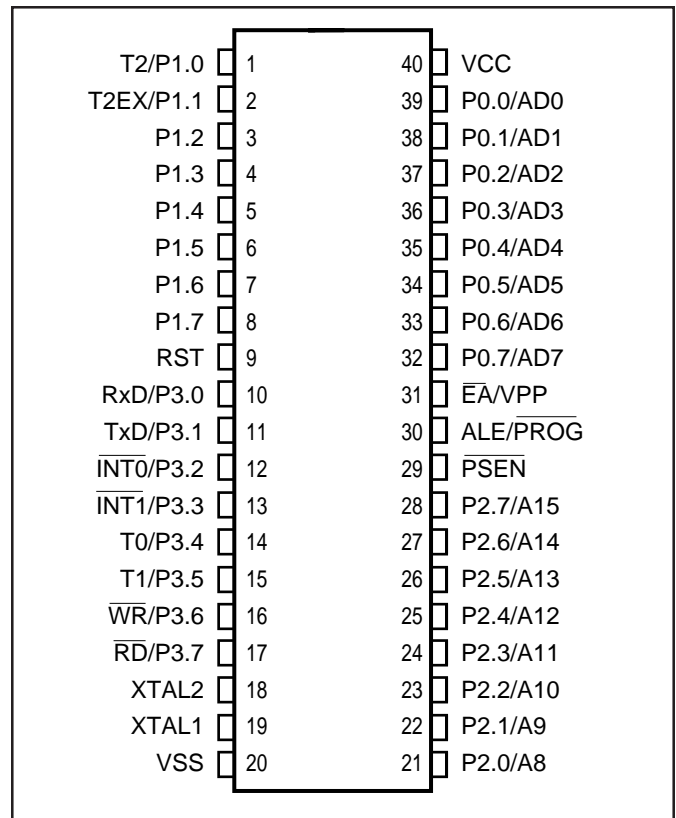

Figure 1. IC89E54/58/64 Pin Configuration: 40-pin DIP

ICSI reserves the right to make changes to its products at any time without notice in order to improve design and supply the best possible product. We assume no responsibility for any errors which may appear in this publication. © Copyright 2000, Integrated Circuit Solution Inc.

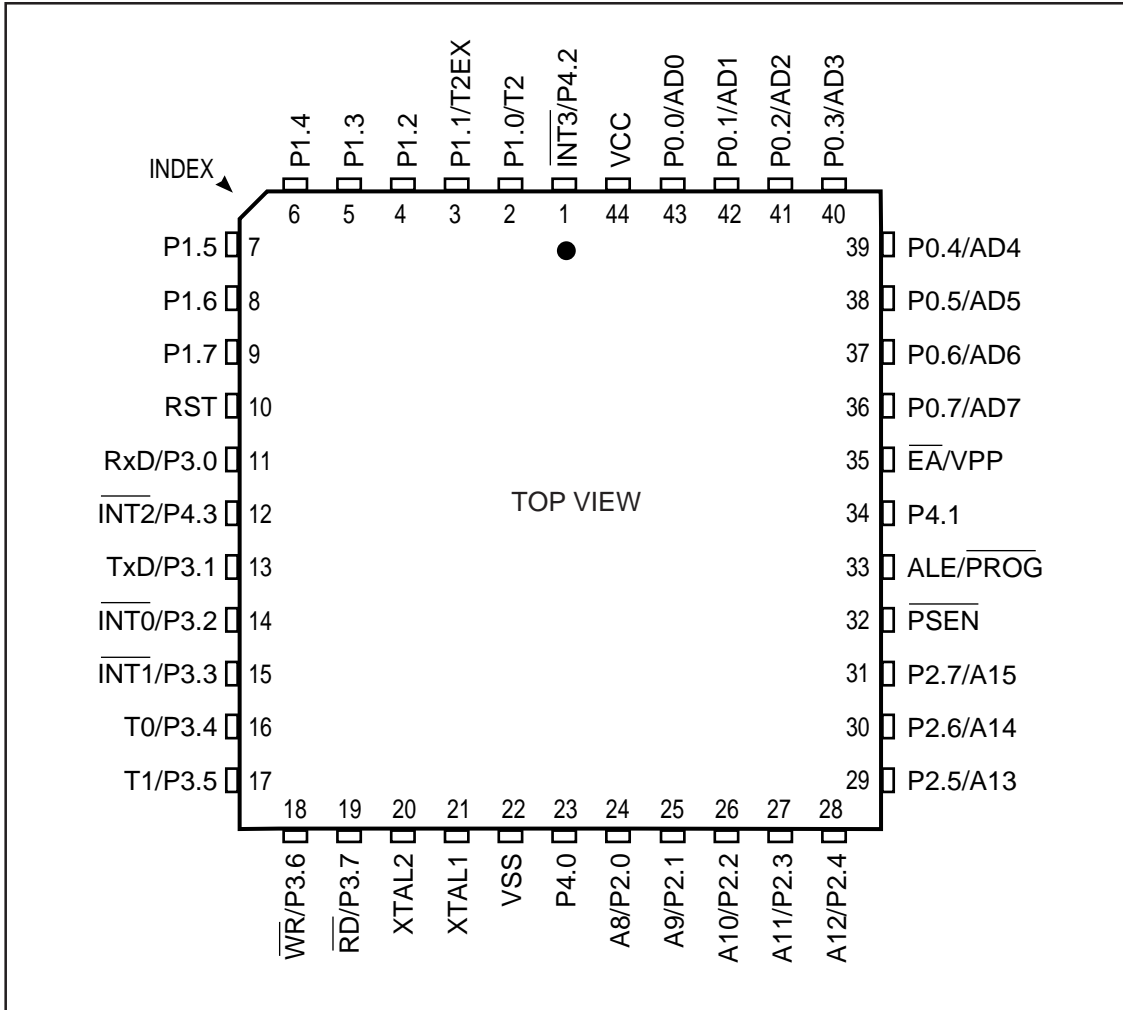

Figure 2. IC89E54/58/64 Pin Configuration: 44-pin PLCC

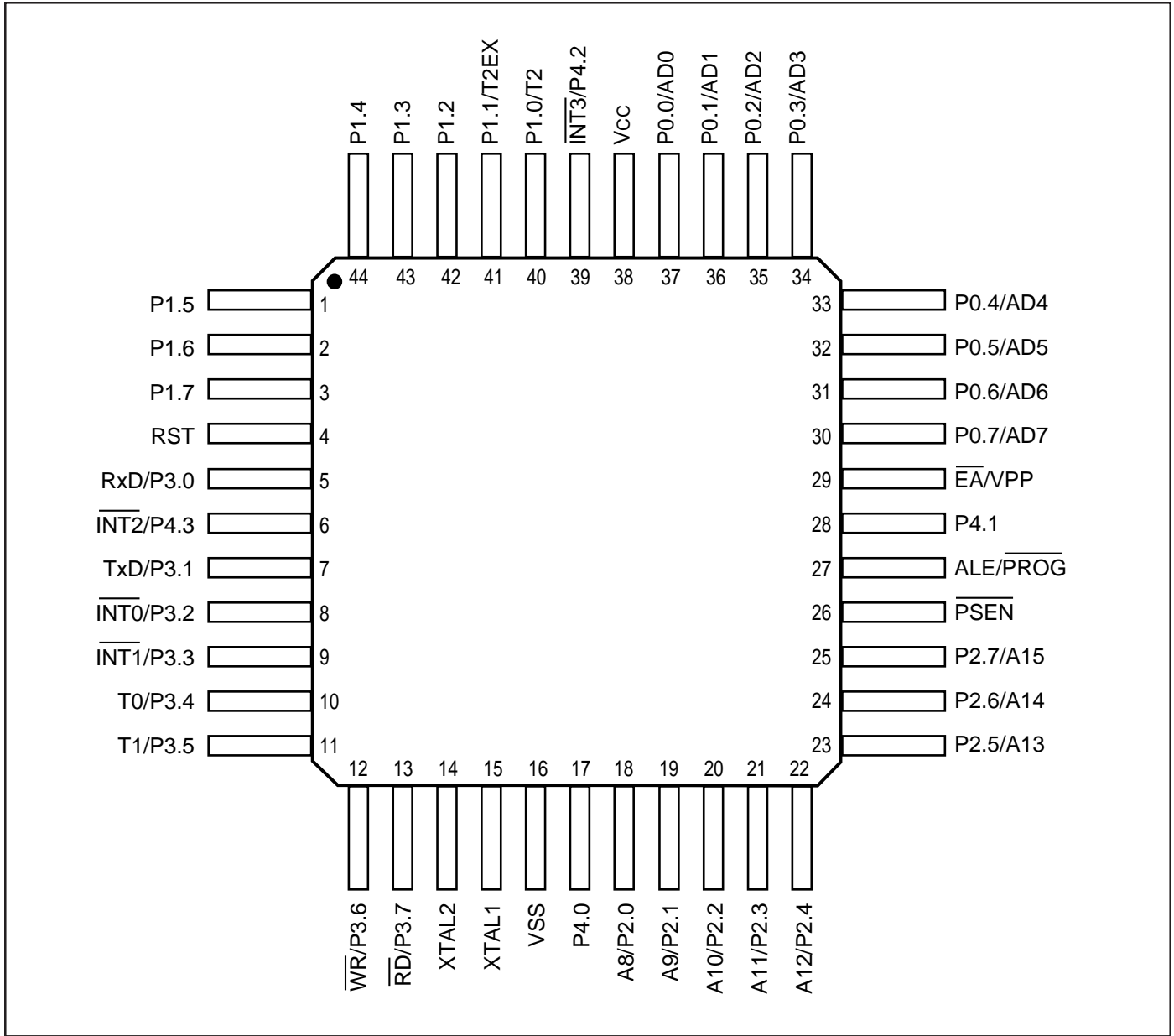

Figure 3. IC89E54/58/64 Pin Configuration: 44-pin PQFP/LQFP

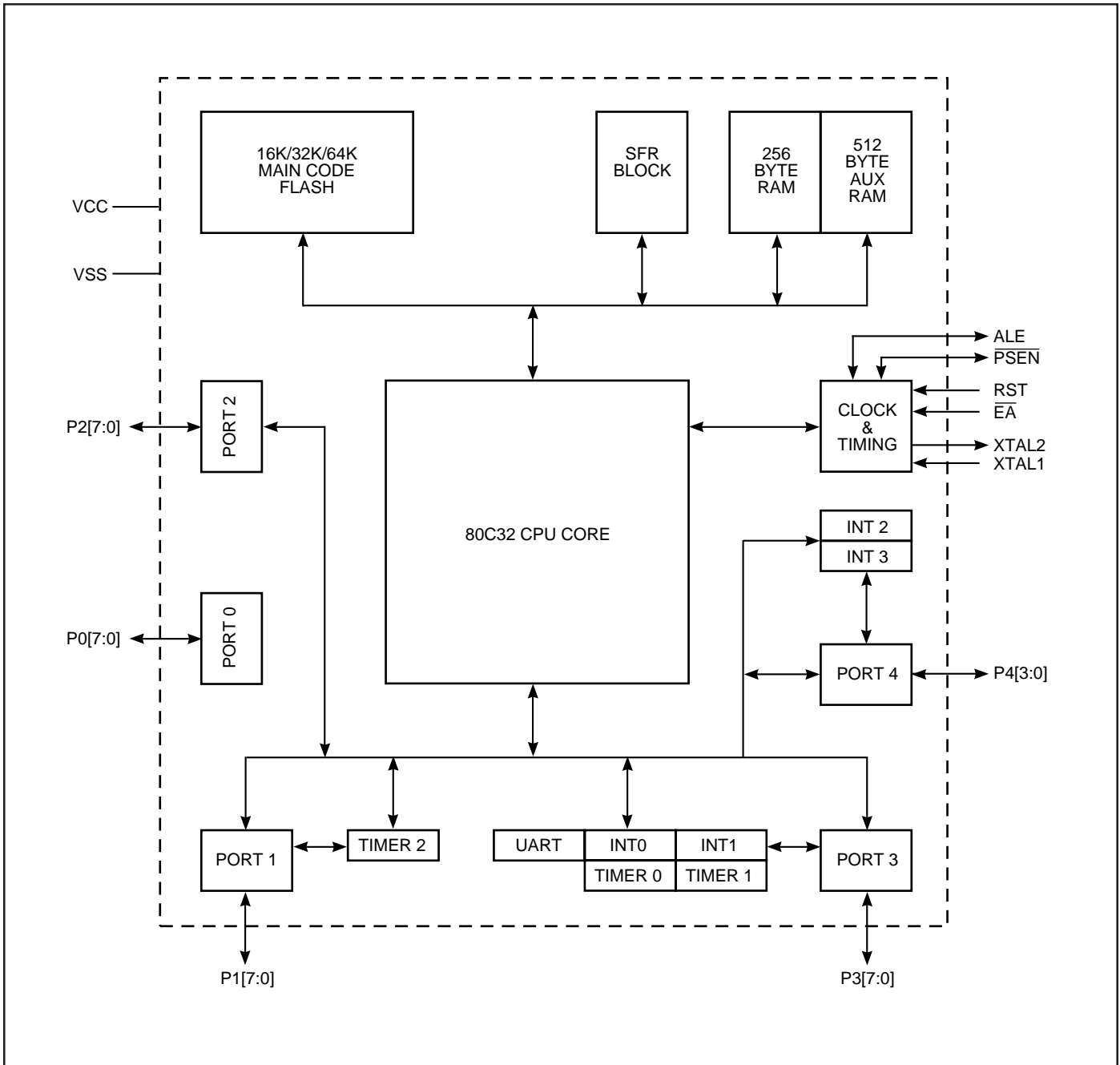

Figure 4. IC89E54/58/64 Block Diagram

Table 1. Detailed Pin Description

Symbol	PDIP	PLCC	PQFP	I/O	Name and Function
P0.0-P0.7	39-32	43-36	37-30	I/O	<p>Port 0: Port 0 is an open-drain, bi-directional I/O port. Port 0 pins that have 1s written to them float and can be used as high-impedance inputs. Port 0 is also the multiplexed low-order address and data bus during accesses to external program and data memory. In this application, it uses strong internal pullups when emitting 1s.</p> <p>Port 0 also receives the command and code bytes during memory program and verification, and outputs the code bytes during program verification. External pullups are required during program verification.</p>
P1.0-P1.7	1-8	2-9	40-44	I/O	<p>Port 1: Port 1 is an 8-bit bi-directional I/O port with internal pullups. Port 1 pins that have 1s written to them are pulled high by the internal pullups and can be used as inputs. As inputs, port 1 pins that are externally pulled low will source current because of the internal pullups.</p> <p>Port 1 also receives the low-order address byte during memory program and verification.</p>
	1	2	40	I	T2(P1.0) : Timer/counter 2 external count input.
	2	3	41	I	T2EX(P1.1) : Timer/counter 2 trigger input.
P2.0-P2.7	21-28	24-31	18-25	I/O	<p>Port 2: Port 2 is an 8-bit bi-directional I/O port with internal pullups. Port 2 pins that have 1s written to them are pulled high by the internal pull-ups and can be used as inputs. As inputs, port 2 pins that are externally pulled low will source current because of the internal pullups. Port 2 emits the high order address byte during fetches from external program memory and during accesses to external data memory that used 16-bit addresses. In this application, it uses strong internal pullups when emitting 1s. During accesses to external data memory that use 8-bit addresses, port 2 emits the contents of the P2 special function register.</p> <p>Port 2 also receives the high-order address bits from A13 to A8 and some control signals during Flash programming and verification. P2.6, P2.7 are the control signals while the chip programs and erases. P2.6 is a program command strobe signal. P2.7 is a data output enable signal.</p>

Table 1. Detailed Pin Description (continued)

Symbol	PDIP	PLCC	PQFP	I/O	Name and Function
P3.0-P3.7	10-17	11, 13-19	5, 7-13	I/O	<p>Port 3: Port 3 is an 8-bit bi-directional I/O port with internal pullups. Port 3 pins that have 1s written to them are pulled high by the internal pullups and can be used as inputs. As inputs, port 3 pins that are externally pulled low will source current because of the internal pullups.</p> <p>Port 3 also serves the special features of the IC89E54/58/64, as listed below:</p> <p>RxD (P3.0): Serial input port. TxD (P3.1): Serial output port. INT0 (P3.2): External interrupt. Serve as A14 during memory program and verification. INT1 (P3.3): External interrupt. Serve as A15 during memory program and verification. T0 (P3.4): Timer 0 external input. T1 (P3.5): Timer 1 external input. WR (P3.6): External data memory write strobe. Control signal during memory program, verification and erase. RD (P3.7): External data memory read strobe. Control signal during memory program, verification and erase.</p>
P4.0-P4.3		23 34 1 12	17 29 39 6	I/O	<p>Port 4: In mode 0, Port 4 is an 8-bit bi-directional I/O port with internal pullups. Port 4 pins that have 1s written to them are pulled high by the internal pullups and can be used as inputs. As inputs, port 4 pins that are externally pulled low will source current because of the internal pullups.</p> <p>In mode 1, 2, 3, Port 4 is an address strobe signal which appears with \overline{RD} or \overline{WR} signals.</p> <p>Port 4 also serves the special features, as listed below:</p> <p>$\overline{INT2}$ (P4.3): External interrupt $\overline{INT3}$ (P4.2): External interrupt</p>
RST	9	10	4	I	<p>Reset: A high on this pin for two machine cycles while the oscillator is running resets the device. An internal resistor to VSS permits a power-on reset using only an external capacitor. A small internal resistor permits power-on reset using only a capacitor connected to VCC.</p> <p>RST is an input control signal during memory program and verification.</p>
XTAL 2	18	20	14	O	Crystal 2: Output from the inverting oscillator amplifier.
XTAL 1	19	21	15	I	Crystal 1: Input to the inverting oscillator amplifier and input to the internal clock generator circuits.

Table 1. Detailed Pin Description (continued)

Symbol	PDIP	PLCC	PQFP	I/O	Name and Function
$\overline{\text{PSEN}}$	29	32	26	O	<p>Program Store Enable: The read strobe to external program memory. When the device is executing code from the external program memory, $\overline{\text{PSEN}}$ is activated twice each machine cycle except that two $\overline{\text{PSEN}}$ activations are skipped during each access to external data memory. $\overline{\text{PSEN}}$ is not activated during fetches from internal program memory.</p> <p>$\overline{\text{PSEN}}$ is an input control signal while memory program and verification.</p>
$\overline{\text{ALE/PROG}}$	30	33	27	I/O	<p>Address Latch Enable: Output pulse for latching the low byte of the address during an address to the external memory. In normal operation, ALE is emitted at a constant rate of 1/6 the oscillator frequency, and can be used for external timing or clocking. Note that one ALE pulse is skipped during each access to external data memory.</p> <p>This pin is also the program pulse input ($\overline{\text{PROG}}$) during programmable memory programming and erase.</p>
$\overline{\text{EA/VPP}}$	31	35	29	I	<p>External access enable: $\overline{\text{EA}}$ must be externally held low to enable the device to fetch code from external program memory locations 0000H to FFFFH. If $\overline{\text{EA}}$ is held high, the device executes from internal program memory unless the program counter contains an address greater than 3FFFH/7FFFH respecting to IC89C54/58 and the device always executes internal program memory in IC89C64.</p> <p>This is also receives the 12 V programming enable voltage (V_{pp}) during Flash programming, when 12 V programming is selected.</p>
Vss	20	22	16		Ground: 0V reference.
Vcc	40	44	38	I	Power Supply: This is the power supply voltage for operation.

OPERATING DESCRIPTION

The detail description of the IC89E54/58/64 included in this description are:

- **Memory Map and Registers**
- **Timer/Counters**
- **Serial Interface**
- **Interrupt System**
- **Other Information**
- **Flash Memory**

MEMORY MAP AND REGISTERS

Program Memory and data memory

Table 2 shows program memory and data memory size versus three products. The IC89E54/58/64 series includes a standard IC80C32 and a 16K/32K/64K Flash Memory. The IC89E54/58/64 includes IC80C32, a 16K/32K/64K Flash and some enhanced functions. The figures 3~5 show IC89E54/58/64 program memory architecture and program memory access status versus $\overline{\text{EA}}$ pin. These enhanced functions are described in later descriptions. The program memory and data memory access ranges are listed table 1. The AUX RAM status is disable after reset, so MOVX instructions will access external RAM. If set ENARAM bit, the AUX RAM will be enabled and MOVX instructions will access AUX RAM in 0000H~01FFH, access external RAM in 0200H~FFFFH. Figure 6 shows the external data memory and AUX RAM accesses relation.

Table 2. Program memory and Data memory sizes

	Main Flash	RAM Size	AUX RAM Size
IC89E54	16K Bytes : [0H~3FFFH]	256 Bytes : [0-FFH]	512 Bytes : [0-1FFH]
IC89E58	32K Bytes : [0H~7FFFH]	256 Bytes : [0-FFH]	512 Bytes : [0-1FFH]
IC89E64	64K Bytes : [0H~FFFFH]	256 Bytes : [0-FFH]	512 Bytes : [0-1FFH]

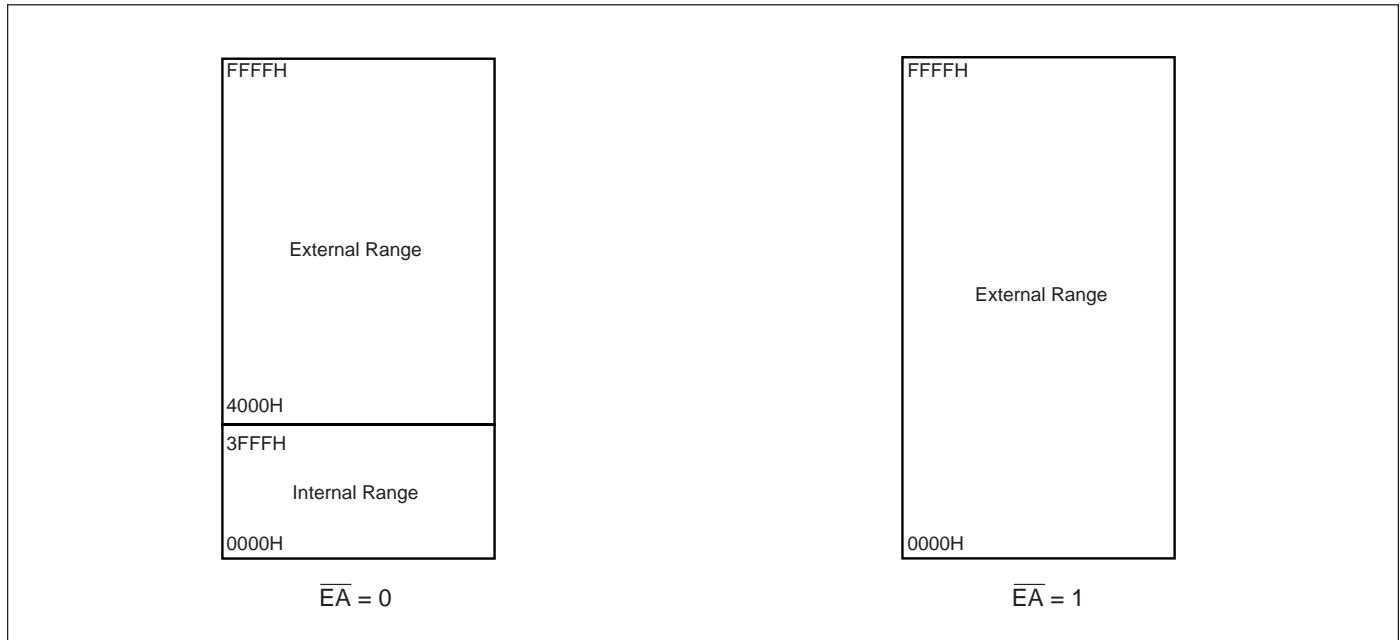

Figure 5. IC89E54 Flash Architecture

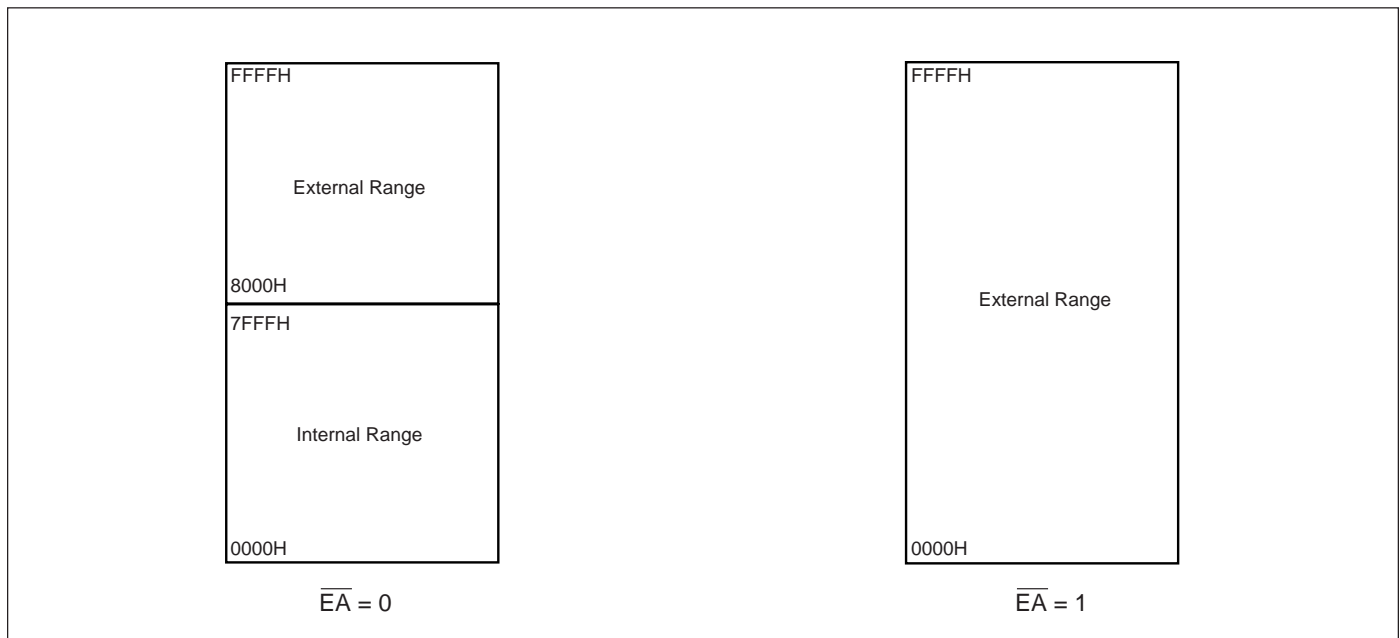

Figure 6. IC89E58 Flash Architecture

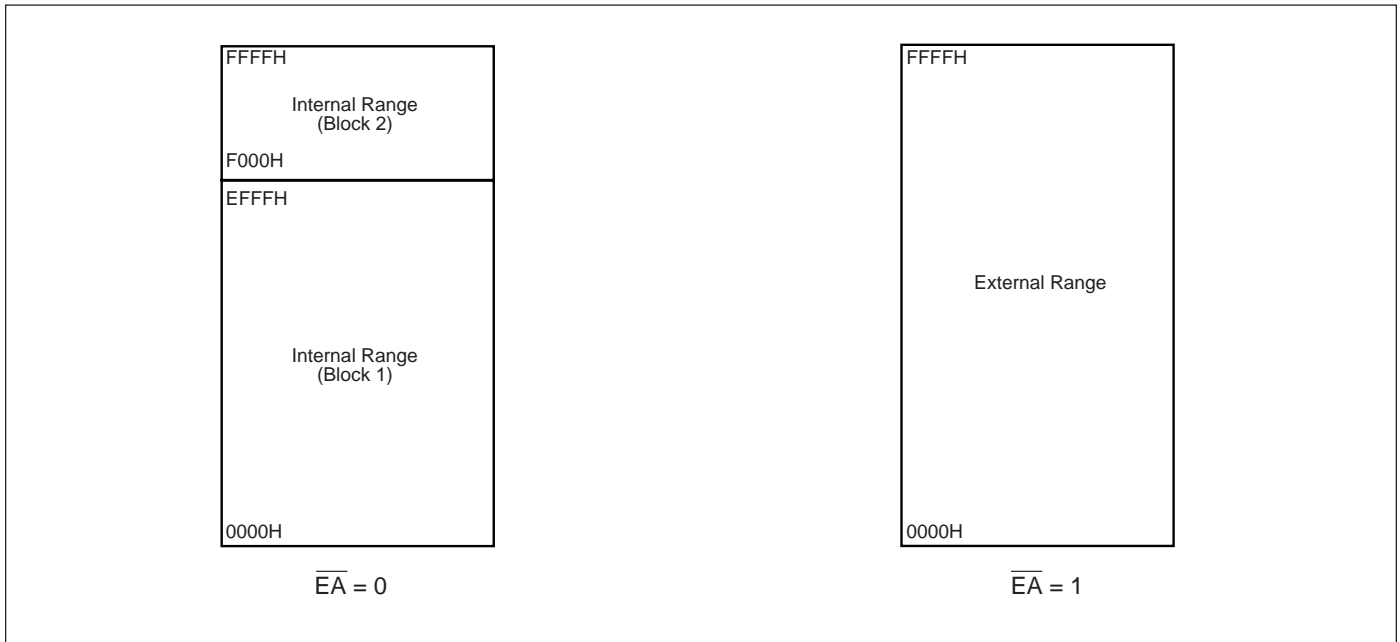

Figure 7. IC89E64 Flash Architecture

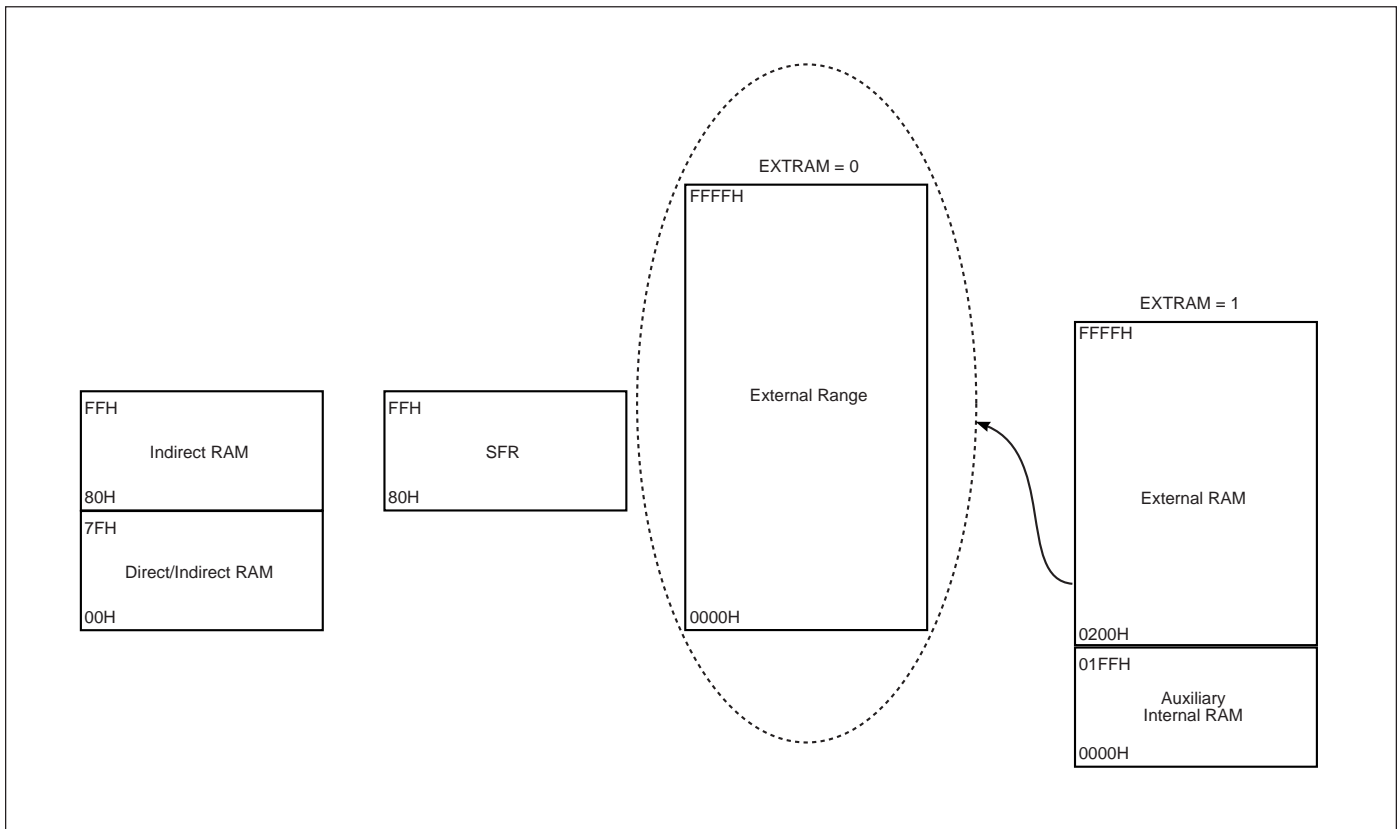

Figure 8. IC89E54/58/64 Data Memory Architecture

F8H									FFH
F0H	B 00000000								F7H
E8H									EFH
E0H	ACC 00000000								E7H
D8H	P4[3:0] XXXX1111								DFH
D0H	PSW 00000000								D7H
C8H	T2CON 00000000		RCAP2L 00000000	RCAP2H 00000000	TL2 00000000	TH2 00000000			CFH
C0H	XICON 00000000		P4CONA 00000000	P4CCONB 00000000					C7H
B8H	IP XX000000								BFH
B0H	P3 11111111				P43AL 00000000	PH43AH 00000000			B7H
A8H	IE 0X000000				P42AL 00000000	P42AH 00000000	P2ECON 0000XX00		AFH
A0H	P2 11111111								A7H
98H	SCON 00000000	SBUF XXXXXXXX					P2EAL 00000000	P2EAH 00000000	9FH
90H	P1 11111111				P41AL 00000000	P41AH 00000000			97H
88H	TCON 00000000	TMOD 00000000	TL0 00000000	TL1 00000000	TH0 00000000	TH1 00000000	AUXR XXX00000		8FH
80H	P0 11111111	SP 00000000	DPL 00000000	DPH 00000000	P40AL 00000000	P40AH 00000000		PCON 0XX00000	87H

Figure 9. IC89E54/58/64 SFRs Map and Reset value (The gray blocks are non-standard.)

These descriptions are added from standard IC80C32. So, more information for SFRs and memory refer to IC80C32.

The timers/counters

Refer to IC80C32 data sheet.

The serial interface

Refer to IC80C32 data sheet.

The interrupt system

There are 8 interrupt vectors in 44 pins package and 6 interrupt vectors in 40 pins package. Eight interrupt vectors only exist in IC89E54/58/64 series. $\overline{INT2}$ and $\overline{INT3}$ are new interrupts that add on standard IC80C32. The interrupt information shows in Table 3. The interrupt architecture shows in figure 10. External interrupt 2 and 3 control register is XICON shown in following.

Two additional external interrupts, $\overline{INT2}$ and $\overline{INT3}$, whose function are similar to those of external interrupt 0 and 1 in the standard 80C32. The functions/status of these interrupts are determined/shown by the bits in the XICON(External Interrupt Control) register. The XICON register is bit-addressable but is not a standard register in the 80C32. Its address is at 0C0H. To set/clear bits in the XICON register, one can use the “SETB (/CLR) bit” instruction.

Table 3. Eight interrupt information

Interrupt Source	Vector Address	Polling Sequence within priority level	Enable Required Settings	Interrupt Type Edge/Level
External Interrupt 0	03H	0 (Highest)	IE.0	TCON.0
Timer/Counter 0	0BH	1	IE.1	-
External Interrupt 1	13H	2	IE.2	TCON.2
Timer/Counter 1	1BH	3	IE.3	-
Serial Port	23H	4	IE.4	-
Timer/Counter 2	2BH	5	IE.5	-
External Interrupt 2 ⁽¹⁾	33H	6	XICON.2	XICON.0
External Interrupt 3 ⁽¹⁾	3BH	7 (Lowest)	XICON.6	XICON.3

Note:

1. Interrupt 2 and interrupt 3 exist in IC89E54/58/64 44 pins package.

XICON(C0H)

	B7	B6	B5	B4	B3	B2	B1	B0
Flag Name	PX3	EX3	IE3	IT3	PX2	EX2	IE2	IT2

Bit	Name	Description
7	PX3	External interrupt 3 priority high if set.
6	EX3	External interrupt 3 enable if set.
5	IE3	If IT3=1, IE3 is set/cleared automatically by hardware when interrupt is detected/served.
4	IT3	External interrupt 3 is falling-edge/low-level triggered when this bit is set/cleared by software.
3	PX2	External interrupt 2 priority high if set.
2	EX2	External interrupt 2 enable if set.
1	IE2	If IT2=1, IE2 is set/cleared automatically by hardware when interrupt is detected/served.
0	IT2	External interrupt 2 is falling-edge/low-level triggered when this bit is set/cleared by software.

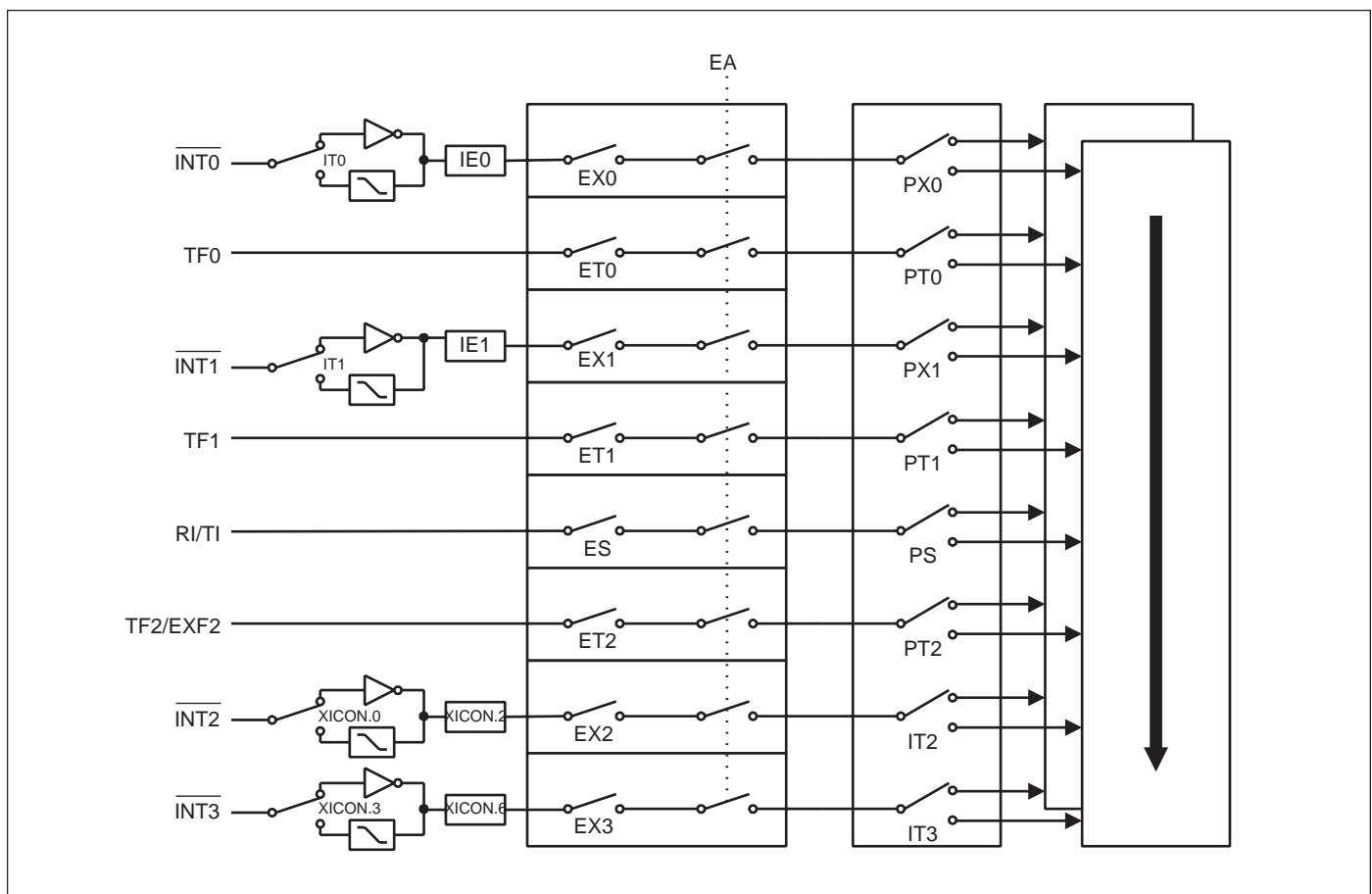

Figure 10. IC89E54/58/64 Interrupt Architecture

These descriptions are added from standard 80C32. So, more detailed information for interrupts refer to IC80C52.

Operation of Power-Save Mode

Refer to IC80C32 data sheet.

Instruction Definitions

Refer to IC80C32 data sheet.

Enhanced Function

Port 4

Port 4, SFR P4 at address D8H, is a 4-bit multipurpose programmable I/O port. Each bit can be configured individually by software. The Port 4 has four different operation modes.

In mode 0, P4.0~P4.3 is a bi-directional I/O port which is same as port 1. P4.2 and P4.3 also serve as external interrupt $\overline{INT3}$ and $\overline{INT2}$ if enabled.

In mode 1, P4.0~P4.3 are read data strobe signals which are synchronized with beginning of read address signal at specified address. These signals can be used as chip-select signals for external peripherals.

In mode 2, P4.0~P4.3 are write data strobe signals which are synchronized with beginning of written address signal at specified address. These signals can be used as chip-select signals for external peripherals.

In mode 3, P4.0~P4.3 are write data strobe signals which are synchronized with beginning of read or written address signal at specified address. These signals can be used as chip-select signals for external peripherals.

When Port 4 is configured with the feature of chip-select signals, the chip-select signal address range depends on the contents of the SFRs P4xAH, P4xAL, P4CONA and P4CONB. The registers P4xAH and P4xAL contain the 16-bit base address of P4.x. The registers P4CONA and P4CONB contain the control bits to configure the Port 4 operating mode.

Here is an example to program the P4.0 as a write strobe signal at the I/O port address 1234H~1237H and positive polarity, and P4.1~P4.3 are used as general I/O ports.

```
MOV P40AH,#12H           ;Define the base I/O address 1234H for P4.0 as an special function pin.
MOV P40AL,#34H
MOV P4CONA,#00001010B   ;Define the P4.0 as a write strobe signal pin and the compartor, length is 14.
MOV P4CONB,#00H         ;P4.1~P4.3 as general I/O port which are the same as Port 1.
MOV P2ECON,#10H        ;Write the P40SINV=1 to inverse the P4.0 write strobe polarity, default is
                        ;negative.
```

Then any instruction MOVX @DPTR,A (with DPTR=1234H~1237H) will generate the positive polarity write strobe signal at pin P4.0. And the instruction MOV P4,#XX will output the bit 3 to bit 1 of data #XX to pin P4.3~P4.1.

The SFRs of Port 4 are described in following. Figure 11 shows architecture of Port 4.

Port 4 base Address Registers : Reset values are 00000000B.

P40AH, P40AL(85H, 84H): The Base address register for comparator of P4.0. P40AH contains the high-order byte of address, P40AL contains the low-order byte of address.

P41AH, P41AL(95H, 94H): The Base address register for comparator of P4.1. P41AH contains the high-order byte of address, P41AL contains the low-order byte of address.

P42AH, P42AL(ADH, ACH): The Base address register for comparator of P4.2. P42AH contains the high-order byte of address, P42AL contains the low-order byte of address.

P43AH, P43AL(B5H, B4H): The Base address register for comparator of P4.3. P43AH contains the high-order byte of address, P43AL contains the low-order byte of address.

P4CONB (C3H)

	B7	B6	B5	B4	B3	B2	B1	B0
Flag Name	P43FUN1	P43FUN0	P43CMP1	P43CMP0	P42FUN1	P42FUN0	P42CMP1	P42CMP0

Bit	Name	Description
7,6	P43FUN1 P43FUN0	=00: Mode 0. P4.3 is a general purpose I/O port which is the same as Port 1. =01: Mode 1. P4.3 is a Read Strobe Signal for chip selecting purpose. The address range depends on the SFRs P43AH, P43AL and flags P43CMP1, P43CMP0. =10: Mode 2. P4.3 is a Write Strobe Signal for chip selecting purpose. The address range depends on the SFRs P43AH, P43AL and flags P43CMP1, P43CMP0. =11: Mode 3. P4.3 is a Read/Write Strobe Signal for chip selecting purpose. The address range depends on the SFRs P43AH, P43AL and flags P43CMP1, P43CMP0.
5,4	P43CMP1 P43CMP0	Chip-select signals for address comparison. =00: Compare the full address (16 bits length) with the base address register P43AH, P43AL. =01: Compare the 15 high bits (A15-A1) of address bus with the base address register P43AH, P43AL. =10: Compare the 14 high bits (A15-A2) of address bus with the base address register P43AH, P43AL. =01: Compare the 8 high bits (A15-A8) of address bus with the base address register P43AH, P43AL.
3,2	P42FUN1 P42FUN0	The P4.2 function control bits which are the similar definition as P42FUN1, P42FUN0.
1,0	P42CMP1 P42CMP0	The P4.2 address comparator length control bits which are the similar definition as P42CMP1, P42CMP0.

P4CONA (C2H)

	B7	B6	B5	B4	B3	B2	B1	B0
Flag Name	P41FUN1	P41FUN0	P41CMP1	P41CMP0	P40FUN1	P40FUN0	P40CMP1	P40CMP0

Bit	Name	Description
7,6	P41FUN1 P41FUN0	The P4.1 function control bits which are the similar definition as P41FUN1, P41FUN0.
5,4	P41CMP1 P41CMP0	The P4.1 address comparator length control bits which are the similar definition as P41CMP1, P41CMP0.
3,2	P40FUN1 P40FUN0	The P4.0 function control bits which are the similar definition as P40FUN1, P40FUN0.
1,0	P40CMP1 P40CMP0	The P4.0 address comparator length control bits which are the similar definition as P40CMP1, P40CMP0.

P4(D8H) :

	B7	B6	B5	B4	B3	B2	B1	B0
Flag Name	-	-	-	-	P4.3	P4.2	P4.1	P4.0

Bit	Name	Description
7-4	-	These bits are reserved.
3	P4.3	Port 4 Data bit that output to pin P4.3 at mode 0.
2	P4.2	Port 4 Data bit that output to pin P4.2 at mode 0.
1	P4.1	Port 4 Data bit that output to pin P4.1 at mode 0.
0	P4.0	Port 4 Data bit that output to pin P4.0 at mode 0.

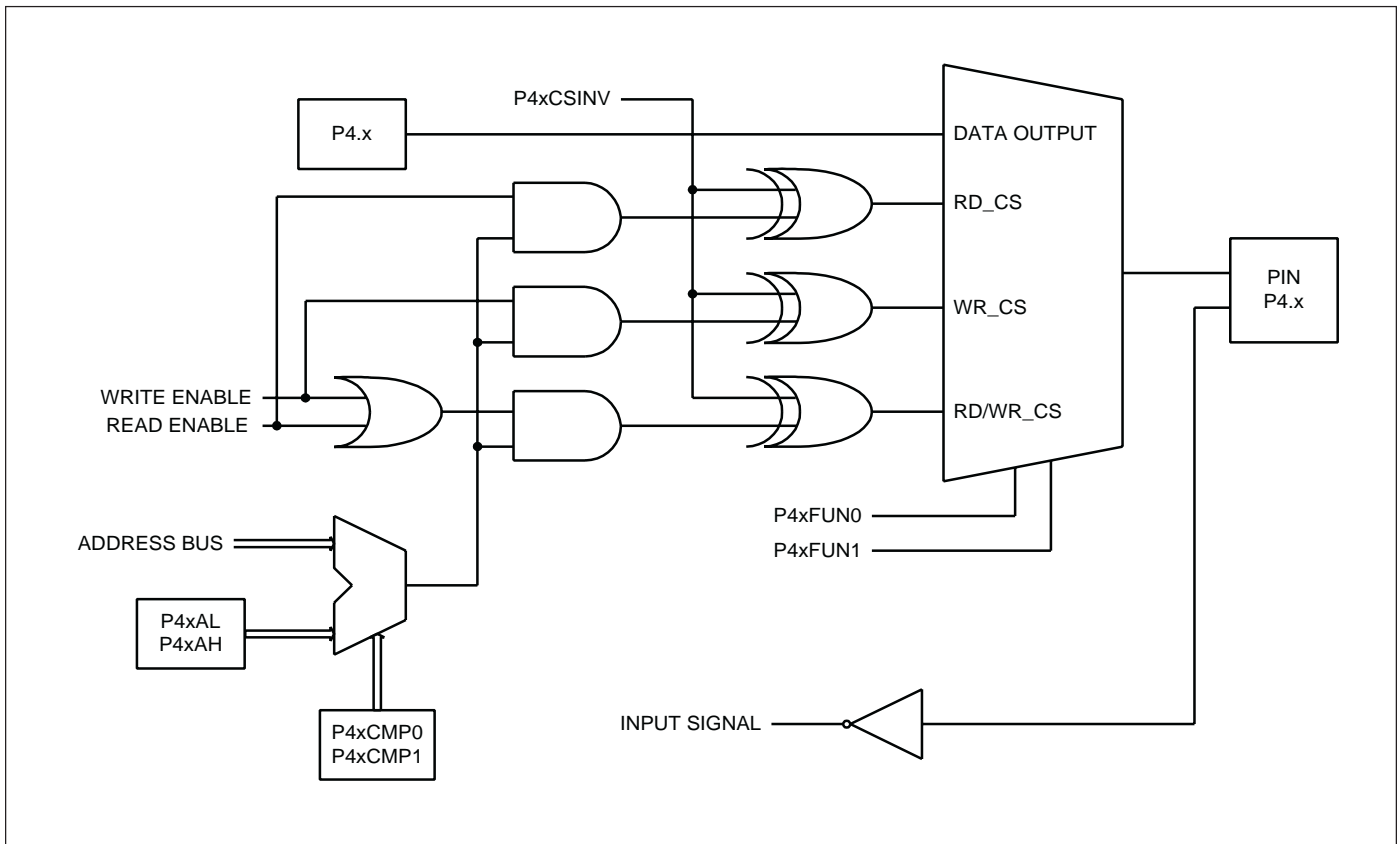

Figure 11. IC89E54/58/64 Port 4 Architecture

P2ECON(AEH)

	B7	B6	B5	B4	B3	B2	B1	B0
Flag Name	P43CSINV	P42CSINV	P41CSINV	P40CSINV	-	-	P2CN1	P2CN0

Bit	Name	Description
7	P43CSINV	The active polarity of P4.3 when pin P4.3 is defined as read/write strobe signal. =1: P4.3 is active high when pin P4.3 is defined as read/write strobe signal. =0: P4.3 is active low when pin P4.3 is defined as read/write strobe signal.
6	P42CSINV	The similarity definition as P43SINV.
5	P41CSINV	The similarity definition as P43SINV.
4	P40CSINV	The similarity definition as P43SINV.
3,2	-	Reserve
1,0	P2CN1, P2CN0	=00 : Pin P2.7-P2.0 is the standard 8052 port 2. =01 : Pins P2.7-P2.0 is input buffer port which the port enable address depends on the content of P2EAL and P2EAH. =10 : Pins P2.7-P2.0 is output-latched port which the port enable address depends on the content of P2EAL and P2EAH. =11 : Undefined.

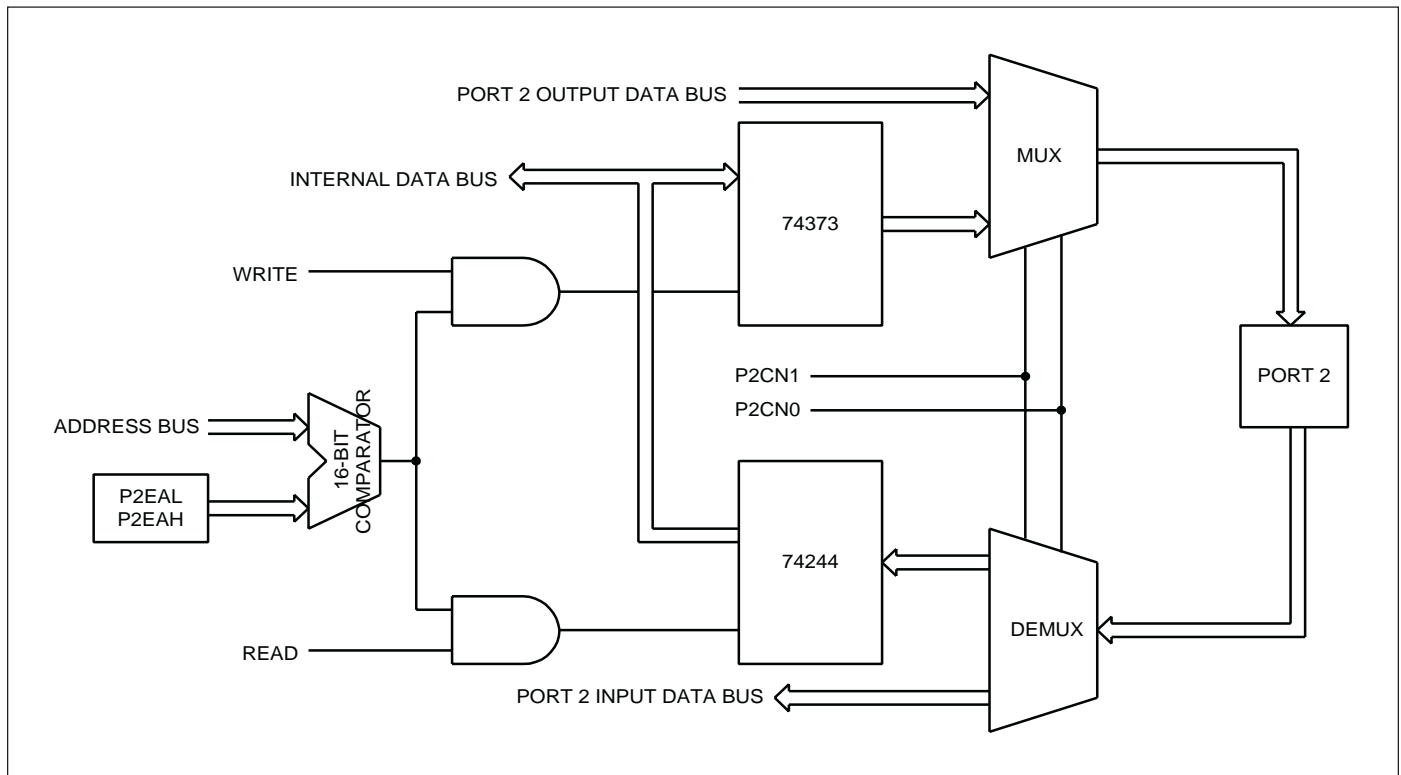

Figure 12. IC89E54/58/64 Port 2 Architecture



P2EAH, P2EAL: The Port Enable Address Registers for Port 2 is defined as input buffer like 74244, or an output-latched logic like a 74373. The P2EAH contains the high-order byte of address, the P2EAL contains the low-order byte of address. Figure 12 shows architecture of Port 2. The following example shows how to program the Port 2 as a output-latched port at address 5678H.

```
MOV    P2EAL,#78H                ;High-order byte of address to enable Port 2 latch function.
MOV    P2EAH,#56H                ;Low-order byte of address to enable Port 2 latch function.
MOV    P2ECON,#02H              ;Configure the port 2 as an output-latched port.
MOV    DPTR,#5678H              ;Move data 5678H to DPTR.
MOV    A,#55H
MOVX   @DPTR,A                  ;The pins P2.7~P2.0 will output and latch the value 55H.
```

When Port 2 is configured as 74244 or 74373 function, the instruction “MOV P2,#XX” will write the data #XX to P2 register only but not output to port pins P2.7~P2.0.

Power Down Mode

When the PD bit in the PCON register is set, the processor enters the power-down mode. In this mode, all of the clocks are stopped, including the oscillator. To exit from power-down mode is by a hardware reset or external interrupts INT0 to INT3 when enabled and set to level triggered. To ensure that the oscillator is stable before the CPU restarts, the IC89E54/58/64 series provide adjustable internal software delay counter. By the default, the device will experience a delay of 2048 clock cycles while the oscillation is recognized. The period of delay is selected by configuring the AUXR register bits OD0, OD1 and OD2.

Reduce EMI Emission

Because of on-chip flash, when a program is running in internal program memory space, the ALE will be unused. The transition of ALE will cause larger noise and EMI effect, so it can be turned off to reduce noise and EMI emission if it is useless. Turning off the ALE signal transition only requires setting the bit 0 of the AUXR SFR, which is located at 08EH. When ALE is turned off, it will be reactivated when the program accesses external ROM/RAM data or jumps to execute an external ROM code. The ALE signal will turn off again after it has been completely accessed or program returns to internal ROM code space. The ALED bit in the AUXR register, when set, disables the ALE output.

AUXR(8EH) : Reset value is xxx0x000B.

	B7	B6	B5	B4	B3	B2	B1	B0
Flag Name	-	-	-	ENARAM	-	OD1	OD0	ALED

Bit	Name	Description															
7-5	-	These bits are reserved.															
4	ENARAM	1, Enable AUX RAM.															
3	-	These bits are reserved.															
2-1	OD1-OD0	Select the delay periods of oscillation when waking up from power-down mode. <table border="1" style="margin-left: 20px;"> <tr> <td>OD1</td> <td>OD0</td> <td>Delay Period</td> </tr> <tr> <td>0</td> <td>0</td> <td>2,048 clock cycles (Default)</td> </tr> <tr> <td>0</td> <td>1</td> <td>8,192 clock cycles</td> </tr> <tr> <td>1</td> <td>0</td> <td>32,768clock cycles</td> </tr> <tr> <td>1</td> <td>1</td> <td>131,072 clock cycles</td> </tr> </table>	OD1	OD0	Delay Period	0	0	2,048 clock cycles (Default)	0	1	8,192 clock cycles	1	0	32,768clock cycles	1	1	131,072 clock cycles
OD1	OD0	Delay Period															
0	0	2,048 clock cycles (Default)															
0	1	8,192 clock cycles															
1	0	32,768clock cycles															
1	1	131,072 clock cycles															
0	ALED	1, Turn off ALE output while CPU accesses internal Flash memory.															



**Power Control Register
PCON(87H) :**

	B7	B6	B5	B4	B3	B2	B1	B0
Flag Name	SMOD	-	-	-	GF1	GF0	PD	IDL

Bit	Name	Description
7	SMOD	Double baud rate bit. If Timer 1 is used to generate baud rate and SMOD=1, the baud rate is doubled when the serial port is used in modes 1, 2, or 3.
6-4	-	These bits are reserved.
3	GF1	General purpose flag bit.
2	GF0	General purpose flag bit.
1	PD	Power down bit. Setting this bit activates power down operation in the IC89E54/58/64.
0	IDL	Idle mode bit. Setting this bit activate idle mode operation in the 89E54/58/64. If 1s are written to PD and IDL at the same time, PD takes precedence.

FLASH MEMORY PROGRAMMING

The Flash architecture of IC89E54/58/64 is shown in Figure 13. IC89E54/58 include block 1 and lock bits block. The signature bytes are fixed value reside in MCU, they are read only. Block 2 resides in IC89E64 only.

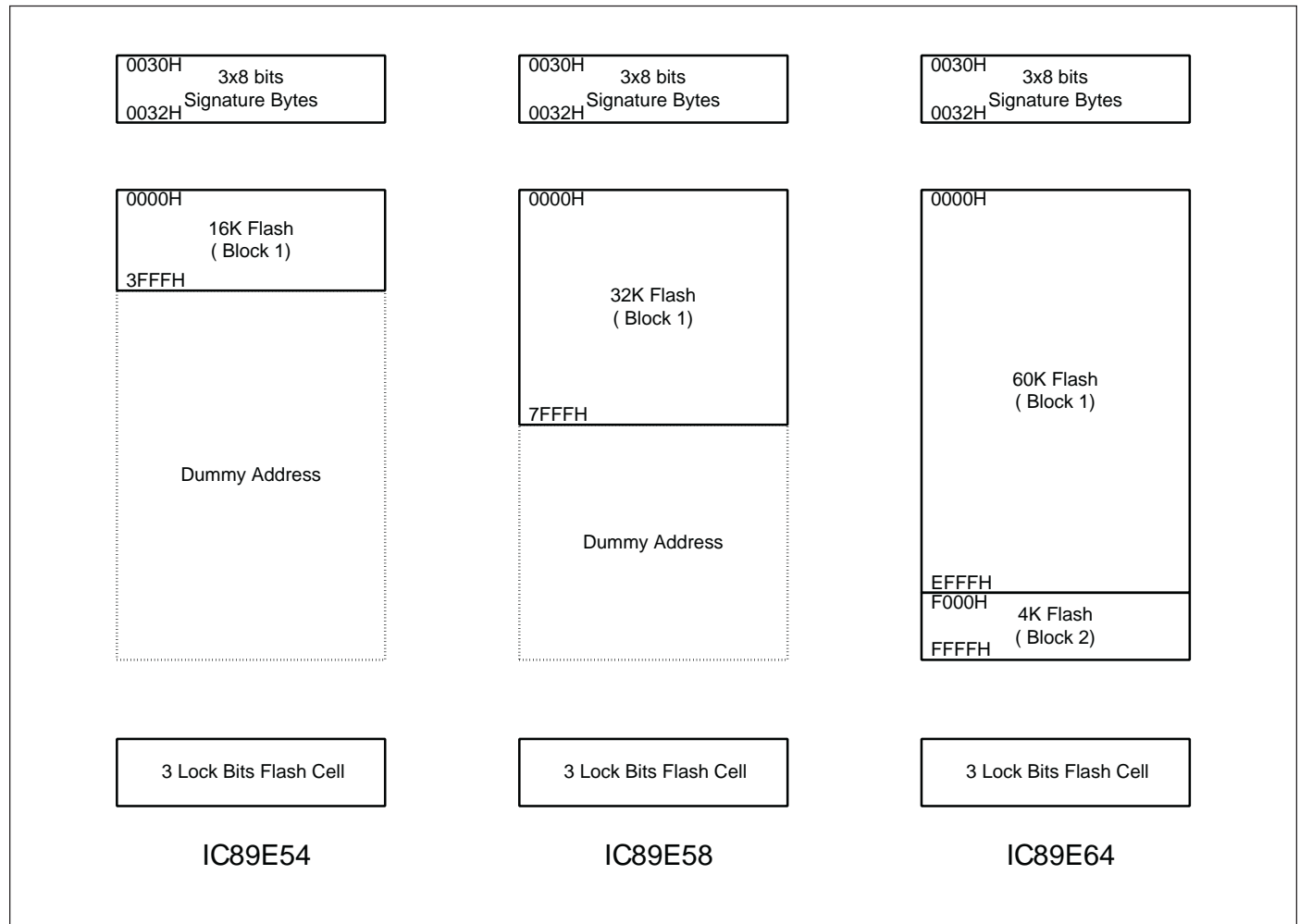

Figure 13. The Flash Architecture of IC89E54/58/64

EXTERNAL HOST MODE

The IC89E54/58/64 provide the user with a direct flash memory access that can be used for programming into the flash memory without using the CPU. The direct flash memory access is entered using the External Host Mode. While the reset input (RST) is continually held active (high), if the \overline{PSEN} pin is forced by an input with low state, the device enters the External Host Mode arming state at this time. The CPU core is stopped from running and all the chip I/O pins are reassigned and become flash memory access and control pins. At this time, the external host should initiate a “Read Signature Bytes” operation. After the completion of the “Read Signature Bytes” operation, the device is armed and enters the External Host Mode. After the device enters into the External Host Mode, the internal flash memory blocks are accessed through the re-assigned I/O port pins by an external host, such as a printed circuit board tester, a PC controlled development board or an MCU programmer.

When the chip is in the external host mode, Port 0 pins are assigned to be the parallel data input and output pins. Port 1 pins are assigned to be the low order address bus signals for the internal flash memory (A0-A7). The first six bits of Port 2 pins (P2[0:5]) are assigned to be the upper order address bus signals for the internal flash memory (A8-A13) along with two of the Port 3 pins (P3.2 as A14 and P3.3 as A15). Two upper order Port 2 pins (P2.6 and P2.7) and two upper order Port 3 pins (P3.6 and P3.7) along with RST, $\overline{\text{PSEN}}$, $\overline{\text{PROG/ALE}}$, $\overline{\text{EA}}$ pins are assigned as the control signal pins. The P3.4 is assigned to be the ready/busy status signal, which can be used for handshaking with the external host during a flash memory programming operation. The flash memory programming operation (Erase, Program, Verify, etc.) is internally self-timed and can be controlled by an external host asynchronously or synchronously.

The insertion of an “arming” command prior to entering the External Host Mode by utilizing the “Read Signature Bytes” operation provides additional protection for inadvertent writes to the internal flash memory cause by a noisy or unstable system environment during the power-up or power unstable conditions.

The External Host Mode uses hardware setup mode, which are decoded from the control signal pins, to facilitate the internal flash memory erase, test and programming process. The External Host Mode Commands are enabled on the falling edge of ALE/PROG. The list in Table 4 outlines all the setup conditions of normal mode. Before entering these written modes must have read 3 signature bytes.

Programming Interface

Some conditions must be satisfied before entering the programming mode. The conditions are listed in Table 4. The interface-controlled signals are matched these conditions, then the IC89E54/58/64 will enter received command mode. The flash command is accepted by the flash command decoder in command received mode. The programming interface is listed in figure 14.

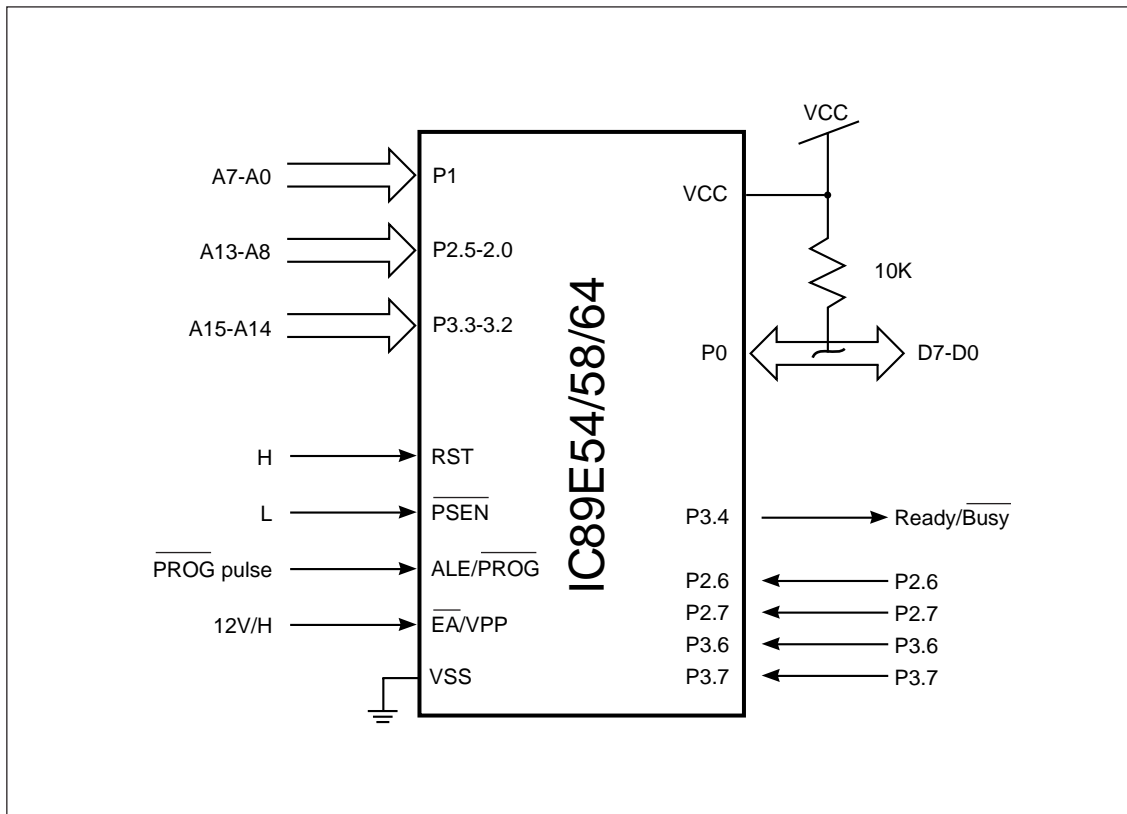









Figure 14. IC89E52/54/64 External Host Programming Signals

Table 4. Flash Programming Mode

Mode ⁽¹⁾	RST	PSEN	PROG	EA	P2.6	P2.7	P3.6	P3.7	P0[7:0]	P1[7:0]	P3[3:2]	COM P2[5:0] HEX ⁽³⁾
Read Signature Byte	H	L	H	H	L	L	L	L	DO	AL	AH	0
Chip Erase	H	L		12V/H	H	L	L	L	X	X	X	1
Block 1 ⁽²⁾ Erase	H	L		12V/H	L	H	L	L	X	X	X	2
Block 2 ⁽²⁾ Erase	H	L		12V/H	L	L	H	L	X	X	X	4
Program Main code	H	L		12V/H	L	H	H	H	DI	AL	AH	E
Program Lock Bit 1	H	L		12V/H	H	H	H	H	X	X	X	F
Program Lock Bit 2	H	L		12V/H	H	H	L	L	X	X	X	3
Program Lock Bit 3	H	L		12V/H	H	L	H	L	X	X	X	5
Verify Lock Bits	H	L	H	H	H	L	L	H	DO[3:1]	X	X	9
Verify Main Code	H	L	H	H	L	L	H	H	DO	AL	AH	C

1. To read the signature bytes 30H, 31H, 32H are needed before any written command. To read signature bytes is needed after any new mode changed. This operation provides additional protection for inadvertent writes to the internal flash memory cause by a noisy or unstable system environment during the power-up or unstable power condition. If any unstable power condition has happened while written operation proceeds, to read signature bytes again will re-enable written command. (Power-on reset voltage is about 2.7V.)
2. Block 1 includes flash address from 0000H to 3FFFH in IC89E54, from 0000H to 7FFFH in IC89E58, from 0000H to EFFFH in IC89E64. Block 2 includes F000H to FFFFH. Block 2 is resident in IC89E64 only.
3. "COM HEX" presents the combination value of [P3.7, P3.6, P2.7, P2.6].

Product Identification

The "Read Signature Bytes" command accesses the Signature Bytes that identify the device as IC89E54/58/64 and the manufacturer code. External programmers primarily use these Signature Bytes, shown in Table 4, in the selection of programming algorithms. The Read Signature Bytes command is selected by the byte code of 00h on P3[7:6] and P2[7:6]. Manufacturer code of ICSI is "D5H" that reside in address 30H of signature. The flash memory sizes of MCU are shown in address 31H, code value 04H respect to 16K main flash memory, code value 08H respect to 32K main flash memory, code value 10H respect to 64K main flash memory. The address 32H value of signature byte respect to written operation VPP value, code value FFH respects to 12V and 55H respects to 5V.

Table 5. Signature Bytes Information

	Addr 30H	Addr 31H	Addr 32H
IC89E54 (VPP=12V)	D5H	04H	FFH
IC89E54 (VPP=5V)	D5H	04H	05H
IC89E58 (VPP=12V)	D5H	08H	FFH
IC89E58 (VPP=5V)	D5H	08H	05H
IC89E64 (VPP=12V)	D5H	10H	FFH
IC89E64 (VPP=5V)	D5H	10H	05H

Arming Command

An arming command must take place before a Written Mode will be recognized by the IC89E54/58/64. This is to prevent accidental triggering of written operation due to noise or programmer error. The arming command is as follows:

A Read Signature Bytes command is issued. This is actually a natural step for the programmer, but will also serve as the arming command. After the above sequence, all other Written Mode commands are enabled. Before the Read Signature Bytes command is received, all other Written Mode commands received are ignored. The IC89E54/8/64 will exit Written Mode if power off, so arming command is needed every power on for entering External Host Command Mode.

External Host Mode Commands

The following is a brief description of the commands. See Table 4 for all signal logic assignments for the External Host Mode Commands. The critical timing for all Erase and Program commands, is self-generated by the flash memory controller on-chip.

The high-to-low transition of the $\overline{\text{PROG}}$ signal initiates the Erase and Program commands, which are synchronized internally. All the data in the memory array will be erased to FFH. Memory addresses that are to be programmed must be in the erased state prior to programming. Selection of the Erase command to use, prior to programming the device, will be dependent upon the contents already in the array and the desired programming field block.

The “Chip Erase” command erases all bytes in both memory blocks of the IC89E54/58/64. This command ignores the “Lock bits” status and will erase the Security Byte. The “Chip Erase” command is selected by the byte code of 01H on P3 [7:6] and P2[7:6].

Flash Operation Status Detection (Ext. Host Handshake)

The IC89E54/58/64 provide two signals mean for an external host to detect the completion of a flash memory operation, therefore the external host can optimize the system Program or Erase cycle of the embedded flash memory. The end of a flash memory operation cycle (Erase or Program) can be detected by monitoring the Ready/ $\overline{\text{Busy}}$ bit at Port 3.4. The following two Program commands are for programming new data into the memory array. Selection of which Program command to use for programming will be dependent upon the desired programming field size. The Program commands will not enable if the Lock bit 2 or Lock Bit 3 is enabled on the selected memory block. The “Program Main Code” command program data into a single byte. Ports P0[0:7] are used for data in. The memory location is selected by P1[0:7], P2[0:5], and P3[2:3] (A0-A15). The “Program Main Code” command is selected by the byte code on P3[6:7] and P2[6:7].

The “Verify Main Code” command allows the user to verify that the IC89E54/58/64 correctly performed an Erase or Program command. Ports P0[0:7] are used for data out. The memory location is selected by P1[0:7], P2[0:5], and P3[2:3] (A0-A15). These commands will not enable if any lock bit is enabled on the selected memory block.

Ready/ $\overline{\text{Busy}}$

The progress of the flash memory programming can be monitored by the Ready/ $\overline{\text{Busy}}$ output signal. The Ready/ $\overline{\text{Busy}}$ indicates whether an Embedded Algorithm in Written State Machine (WSM) is in progress or complete. The RY/ $\overline{\text{BY}}$ status is valid after the falling edge of the programming or erase controlled signal. If the output is low (Busy), the device is in an erasing/programming state with an internal verification. If the output is high, the device is ready to read data. If Ready/ $\overline{\text{Busy}}$ signal doesn't generate a low pulse or doesn't return from low to high in an expected time, the programming/erasing action will be failed.



Programming a IC89E54/58/64

To program new data into the memory array, supply 5 volts to VDD and RST, and perform the following steps.

1. Set RST to high and $\overline{\text{PSEN}}$ to low.
2. Read the “Read Signature Bytes” command to ensure the correct programming algorithm.
3. Raise $\overline{\text{EA}}$ High (either 12V or 5V).
4. Verify that the memory blocks for programming are in the erased state, FFH. If they are not erased, then erase them using the Chip Erase command. (Chip Erase operation will have a Ready/ $\overline{\text{Busy}}$ signal output from P3.4, if Ready/ $\overline{\text{Busy}}$ signal doesn’t return from low to high in 7.2 sec, the Chip Erase operation will be failed.)
5. Set P2.6, P2.7, P3.6, P3.7 to a properly programming combination.
6. Select the memory location using the address lines (P1[0:7], P2[0:5], P3[2:3]).
7. Present the data in on P0[0:7].
8. Pulse ALE/ $\overline{\text{PROG}}$.
9. Wait for low to high transition on Ready/ $\overline{\text{Busy}}$ (P3.4). If Ready/ $\overline{\text{Busy}}$ is from low to high, this address is programmed completely. If Ready/ $\overline{\text{Busy}}$ pin don’t return from low to high in 720us while programming one byte, the Programming operation will be failed.
10. Repeat steps 6~9 until programming is finished.

Lock bits Features

The IC89E54/58/64 provide three lock bits to protect the embedded program against software piracy. These three bytes are user programmable. The relation between lock bits status and protection type are listed in table 6.

Table 6. Lock Bits Features

	Program Lock bits			Protection in Normal Mode
	LB1	LB2	LB3	
1	U	U	U	No program lock feature enabled.
2	P	U	U	MOVC instructions executed from external program memory are disabled from fetching code bytes from internal memory, $\overline{\text{EA}}$ is sampled and latched on reset, and Data verification is disabled. (“Verify Signature Byte” and “Verify Lock Bits are still enabled.)
3	P	P	U	Same as 2, also further written operation of the Flash is disabled
4	P	P	P	Same as 3, also external execution is disabled.

Special Issue

There are two conditions must be sure. One is P2.6 and P2.7 can not be low levels when RST pin falling edge. Another is P4.3 can not be low level while RST falling edge. One of upper case is generate, the program will not be executing correctly.

ABSOLUTE MAXIMUM RATINGS

Parameter	Rating	Unit
Operating Temperature Under Bias	0 to +70	°C ⁽¹⁾
Storage Temperature Range	-65 to +125	°C
Voltage on any other pin to Vss	-2.0 to +7.0	V ⁽²⁾
Power Dissipation (Based on package heat transfer limitations, not device power consumption)	1.5	W

Note:

1. Operating temperature is for commercial products defined by this specification.
2. Minimum DC input voltage is -0.5V. During transitions, inputs may undershoot to -2.0V for periods less than 20 ns. Maximum DC voltage on output pins is Vcc + 0.5V which may overshoot to Vcc + 2.0V for periods less than 20 ns.

OPERATING RANGE⁽¹⁾

Range	Ambient Temperature	Vcc	Oscillator Frequency
Commercial	0°C to +70°C	+4.5V to +5V	3.5 to 40 MHz

Note:

1. Operating ranges define those limits between which the functionality of the device is guaranteed.

DC CHARACTERISTICS

(Ta = 0°C to 70°C; VCC = 5V+10% ; VSS = 0V)

Symbol	Parameter	Test conditions	Min	Max	Unit
V _{IL}	Input low voltage		-0.5	0.2V _{CC} - 0.1	V
V _{IL1}	Input low voltage (XTAL1, \overline{EA})		-0.5	0.2V _{CC} - 0.3	V
V _{IH}	Input high voltage (except XTAL 1, RST, \overline{EA})		0.2V _{CC} + 0.9	V _{CC} + 0.5	V
V _{IH1}	Input high voltage (XTAL 1, \overline{EA})		0.7V _{CC}	V _{CC} + 0.5	V
V _{SCH+}	RST positive schmitt-trigger threshold voltage		0.7V _{CC}	V _{CC} + 0.5	V
V _{SCH-}	RST negative schmitt-trigger threshold voltage		0	0.3V _{CC}	V
V _{OL} ⁽¹⁾	Output low voltage (Ports 1, 2, 3)	I _{OL} = 100 μA	—	0.3	V
		I _{OL} = 1.6 mA	—	0.45	V
		I _{OL} = 3.5 mA	—	1.0	V
V _{OL1} ⁽¹⁾	Output low voltage (Port 0, ALE, \overline{PSEN})	I _{OL} = 200 μA	—	0.3	V
		I _{OL} = 3.2 mA	—	0.45	V
		I _{OL} = 7.0 mA	—	1.0	V
V _{OH}	Output high voltage (Ports 1, 2, 3, ALE, \overline{PSEN})	I _{OH} = -10 μA V _{CC} = 4.5V ~ 5.5V	0.9V _{CC}	—	V
		I _{OL} = -25 μA	0.75V _{CC}	—	V
		I _{OL} = -60 μA	2.4	—	V
V _{OH1}	Output high voltage (Port 0, ALE, \overline{PSEN})	I _{OH} = -80 μA V _{CC} = 4.5V ~ 5.5V	0.9V _{CC}	—	V
		I _{OH} = -300 μA	0.75V _{CC}	—	V
		I _{OH} = -800 μA	2.4	—	V
I _{IL}	Logical 0 input current (Ports 1, 2, 3)	V _{IN} = 0.45V	—	-50	μA
I _{LI}	Input leakage current (Port 0)	V _{IN} = 0.45V or V _{CC}	-10	+10	μA
I _{TL}	Logical 1-to-0 transition current (Ports 1, 2, 3)	V _{IN} = 2.0V	—	-650	μA
R _{RST}	RST pulldown resistor	V _{IN} = 0V	50	300	KΩ

Note:

1. Under steady state (non-transient) conditions, I_{OL} must be externally limited as follows:

Maximum I_{OL} per port pin: 10 mA

Maximum I_{OL} per 8-bit port

Port 0: 26 mA

Ports 1, 2, 3: 15 mA

Maximum total I_{OL} for all output pins: 71 mA

If I_{OL} exceeds the test condition, V_{OL} may exceed the related specification.

Pins are not guaranteed to sink greater than the listed test conditions.

POWER SUPPLY CHARACTERISTICS

Symbol	Parameter	Test conditions	Min	Max	Unit					
I _{cc}	Power supply current ⁽¹⁾	V _{cc} =5.0V								
						Active mode	12 MHz	—	20	mA
							16 MHz	—	26	mA
							20 MHz	—	32	mA
							24 MHz	—	38	mA
							32 MHz	—	50	mA
							40 MHz	—	62	mA
							Idle mode	12 MHz	—	5
						16 MHz		—	6	mA
						20 MHz		—	7.6	mA
						24 MHz		—	9	mA
						32 MHz		—	12	mA
						40 MHz		—	15	mA
						Power-down mode		V _{cc} =5.0V	—	50

Note:

1. The I_{cc} test conditions are shown below. Minimum V_{cc} for Power Down is 2 V.

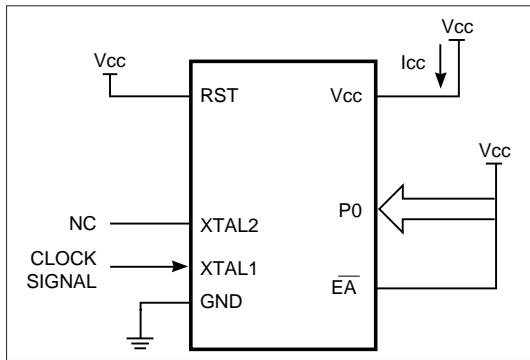

Figure 15. Active Mode

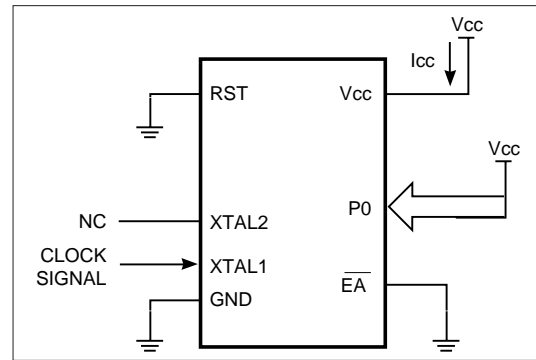
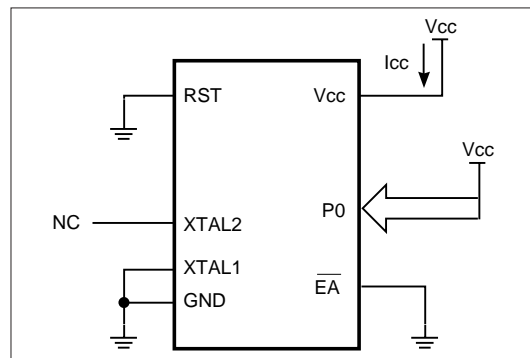

Figure 16. Idle Mode



**Figure 17. Power Mode
(V_{cc}=2.0V~6.0V)**

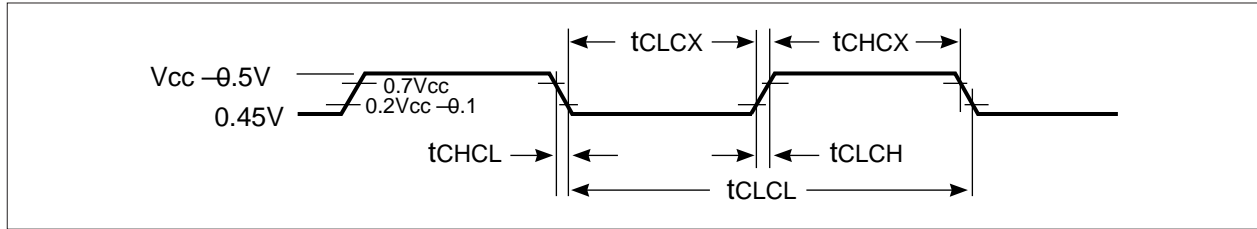

Figure 18. Clock Signal Waveform for Icc Tests in Active and Idle Mode ($t_{CLCH} = t_{CHCL} = 5 \text{ ns}$)

AC CHARACTERISTICS

($T_a = 0^\circ\text{C}$ to 70°C ; $V_{CC} = 5\text{V} \pm 10\%$; $V_{SS} = 0\text{V}$; C_1 for port 0, ALE and $\overline{\text{PSEN}}$ Outputs = 100pF; C_1 for other outputs = 80pF)

EXTERNAL MEMORY CHARACTERISTICS

Symbol	Parameter	24 MHz Clock		40 MHz Clock		Variable Oscillator (3.5 - 40 MHz)		Unit
		Min	Max	Min	Max	Min	Max	
1/tCLCL	Oscillator frequency	—	—	—	—	3.5	40	MHz
tLHLL	ALE pulse width	68	—	35	—	$2t_{CLCL} - 15$	—	ns
tAVLL	Address valid to ALE low	26	—	10	—	$t_{CLCL} - 15$	—	ns
tLLAX	Address hold after ALE low	31	—	15	—	$t_{CLCL} - 10$	—	ns
tLLIV	ALE low to valid instr in	—	147	—	80	—	$4t_{CLCL} - 20$	ns
tLLPL	ALE low to $\overline{\text{PSEN}}$ low	31	—	15	—	$t_{CLCL} - 10$	—	ns
tPLPH	$\overline{\text{PSEN}}$ pulse width	110	—	60	—	$3t_{CLCL} - 15$	—	ns
tPLIV	$\overline{\text{PSEN}}$ low to valid instr in	—	105	—	55	—	$3t_{CLCL} - 20$	ns
tPXIX	Input instr hold after $\overline{\text{PSEN}}$	0	—	0	—	0	—	ns
tPXIZ	Input instr float after $\overline{\text{PSEN}}$	—	37	—	20	—	$t_{CLCL} - 5$	ns
tAVIV	Address to valid instr in	—	188	—	105	—	$5t_{CLCL} - 20$	ns
tPLAZ	$\overline{\text{PSEN}}$ low to address float	—	10	—	10	—	10	ns
tRLRH	$\overline{\text{RD}}$ pulse width	230	—	130	—	$6t_{CLCL} - 20$	—	ns
tWLWH	$\overline{\text{WR}}$ pulse width	230	—	130	—	$6t_{CLCL} - 20$	—	ns
tRLDV	$\overline{\text{RD}}$ low to valid data in	—	157	—	90	—	$4t_{CLCL} - 10$	ns
tRHDX	Data hold after $\overline{\text{RD}}$	0	—	0	—	0	—	ns
tRHDX	Data float after $\overline{\text{RD}}$	—	78	—	45	—	$2t_{CLCL} - 5$	ns
tLLDV	ALE low to valid data in	—	282	—	165	—	$7t_{CLCL} - 10$	ns
tAVDV	Address to valid data in	—	323	—	190	—	$8t_{CLCL} - 10$	ns
tLLWL	ALE low to $\overline{\text{RD}}$ or $\overline{\text{WR}}$ low	105	145	55	95	$3t_{CLCL} - 20$	$3t_{CLCL} + 20$	ns
tAVWL	Address to $\overline{\text{RD}}$ or $\overline{\text{WR}}$ low	146	—	80	—	$4t_{CLCL} - 20$	—	ns
tQVWX	Data valid to $\overline{\text{WR}}$ transition	26	—	10	—	$t_{CLCL} - 15$	—	ns
tWHQX	Data hold after $\overline{\text{WR}}$	31	—	15	—	$t_{CLCL} - 10$	—	ns
tRLAZ	$\overline{\text{RD}}$ low to address float	—	0	—	0	—	0	ns
tWHLH	$\overline{\text{RD}}$ or $\overline{\text{WR}}$ high to ALE high	26	57	10	40	$t_{CLCL} - 15$	$t_{CLCL} + 15$	ns

SERIAL PORT TIMING: SHIFT REGISTER MODE

Symbol	Parameter	24 MHz Clock		40 MHz Clock		Variable Oscillator (3.5-40 MHz)		Unit
		Min	Max	Min	Max	Min	Max	
txLXL	Serial port clock cycle time	490	510	290	310	$12t_{CLCL}-10$	$12t_{CLCL}+10$	ns
tQVXH	Output data setup to clock rising edge	406	—	240	—	$10t_{CLCL}-10$	—	ns
txHQX	Output data hold after clock rising edge	73	—	40	—	$2t_{CLCL}-10$	—	ns
txHDX	Input data hold after clock rising edge	0	—	0	—	0	—	ns
txHDV	Clock rising edge to input data valid	—	417	—	250	—	$10t_{CLCL}$	ns

EXTERNAL CLOCK DRIVE CHARACTERISTICS

Symbol	Parameter	Min	Max	Unit
$1/t_{CLCL}$	Oscillator Frequency	3.5	40	MHz
tCHCX	High time	10	—	ns
tCLCX	Low time	10	—	ns
tCLCH	Rise time	—	10	ns
tCHCL	Fall time	—	10	ns

Flash Program/Erase and Verification & Test Mode Characteristics

Symbol	Parameter	Min	Max	Unit
Vpph	Programming and Erase Enable Voltage	11.5	12.5	V
Vppl	Programming and Erase Enable Voltage	4.5	6.0	V
Ipph	Programming and Erase Enable Current while VPP=Vpph	-	2.0	mA
Ippl	Programming and Erase Enable Current while VPP=Vppl	-	1.0	mA
tWSCV	Power Setup to Command Setup Low	10	-	ms
tCVQV	Command Valid to Data Output Valid	-	60	ns
tAVQV	Address Valid to Data Output Valid	-	60	ns
tCVPL	Command Valid to $\overline{\text{PROG}}$ Low	30	-	ns
tSHPL	VPP Setup to $\overline{\text{PROG}}$ Low	30	-	ns
tAVPL	Address Setup to $\overline{\text{PROG}}$ Low	30	-	ns
tDVPL	Data Setup to $\overline{\text{PROG}}$ Low	30	-	ns
tPLBL	$\overline{\text{PROG}}$ Low to $\overline{\text{Busy}}$ Low	1	10	us
tBLCX	Command Hold after $\overline{\text{Busy}}$ Low	30	-	ns
tBLAX	Address Hold after $\overline{\text{Busy}}$ Low	30	-	ns
tBLPH	$\overline{\text{Busy}}$ Low to $\overline{\text{PROG}}$ high	30	-	ns
tBLDX	Data Hold after $\overline{\text{Busy}}$ Low	30	-	us
tBLBH	$\overline{\text{Busy}}$ Low to $\overline{\text{Busy}}$ High	15	480	us
tBHSL	VPP Hold after $\overline{\text{Busy}}$ High	1	-	us
tAXQX	Output Hold after Address Release	0	-	ns
tCXQX	Output Hold after Command Release	0	-	ns
tLBHE	$\overline{\text{Busy}}$ Time while Chip Erase	-	4.5	Sec
tLBHE1	$\overline{\text{Busy}}$ Time while Block 1 Erase (IC89E54)	-	1.2	Sec
tLBHE2	$\overline{\text{Busy}}$ Time while Block 1 Erase (IC89E58)	-	2.4	Sec
tLBHE3	$\overline{\text{Busy}}$ Time while Block 1 Erase (IC89E64)	-	4.0	Sec
tLBHE4	$\overline{\text{Busy}}$ Time while Block 2 Erase (IC89E64)	-	0.7	Sec

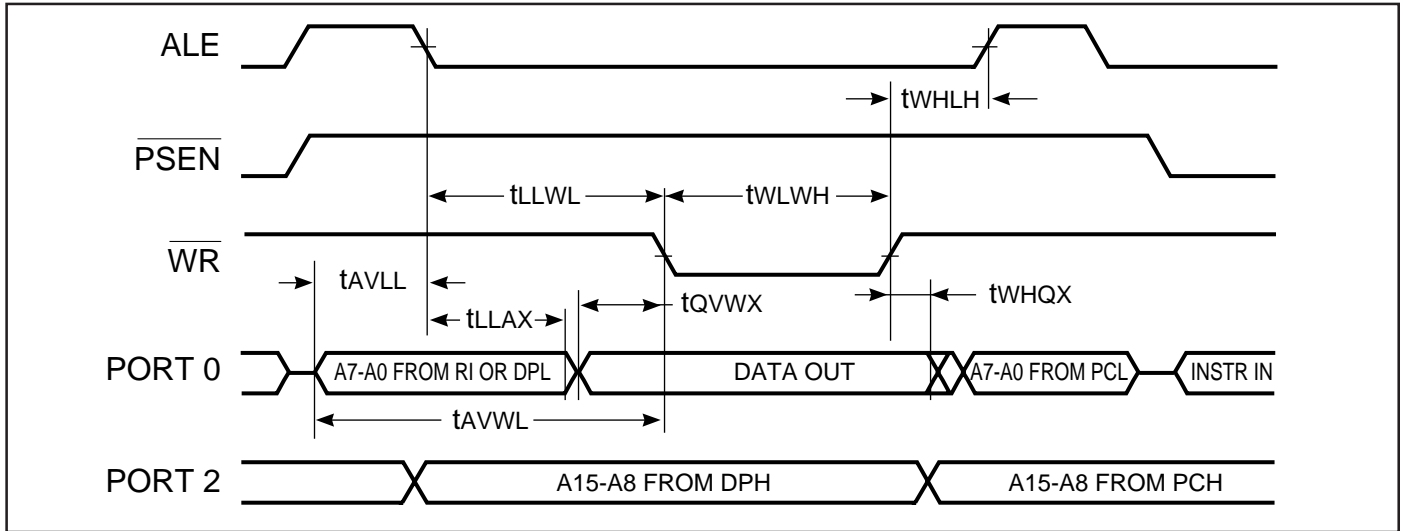

Figure 21. External Data Memory Write Cycle

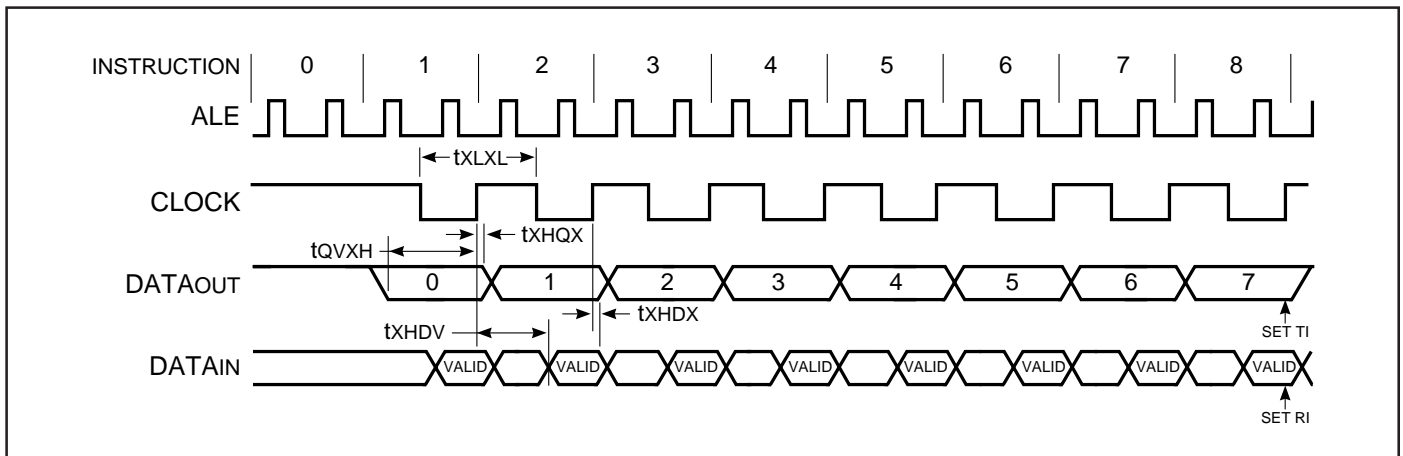

Figure 22. Shift Register Mode Timing Waveform

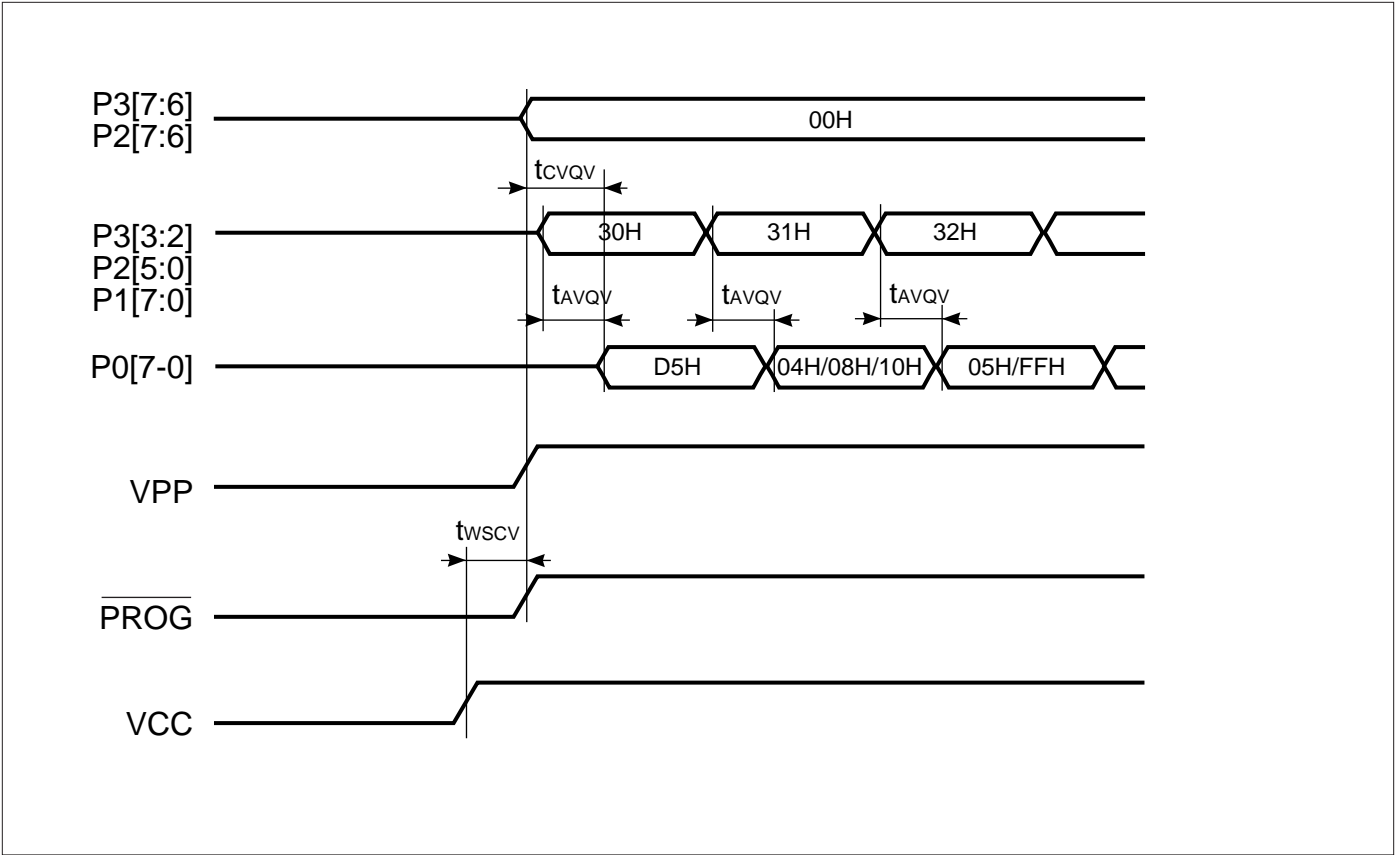

Figure 23. Read Signature bytes Timing(Arming Command)

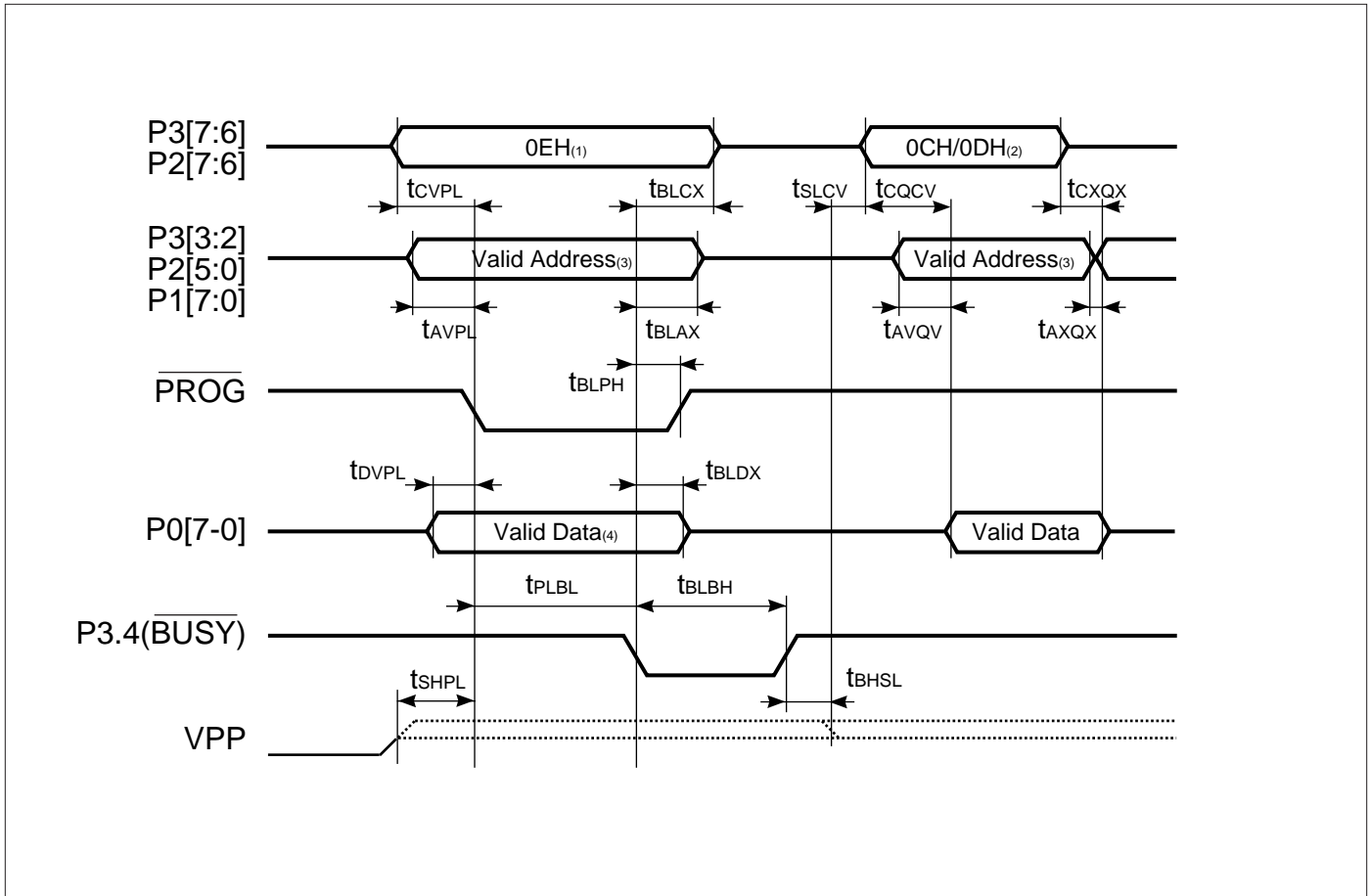

Figure 24. Programming Timing

Note:

1. 0EH is for code memory programming . In lock bits programming, 0FH, 03H, 05H respect to lock bit 1, 2, 3.
2. 0CH is for code memory verification and 0DH is for concurrent memory verification. 09H is for Lock bits verification.
3. Address don't care while lock bits' programming or verification.
4. Data don't care while lock bits' programming.

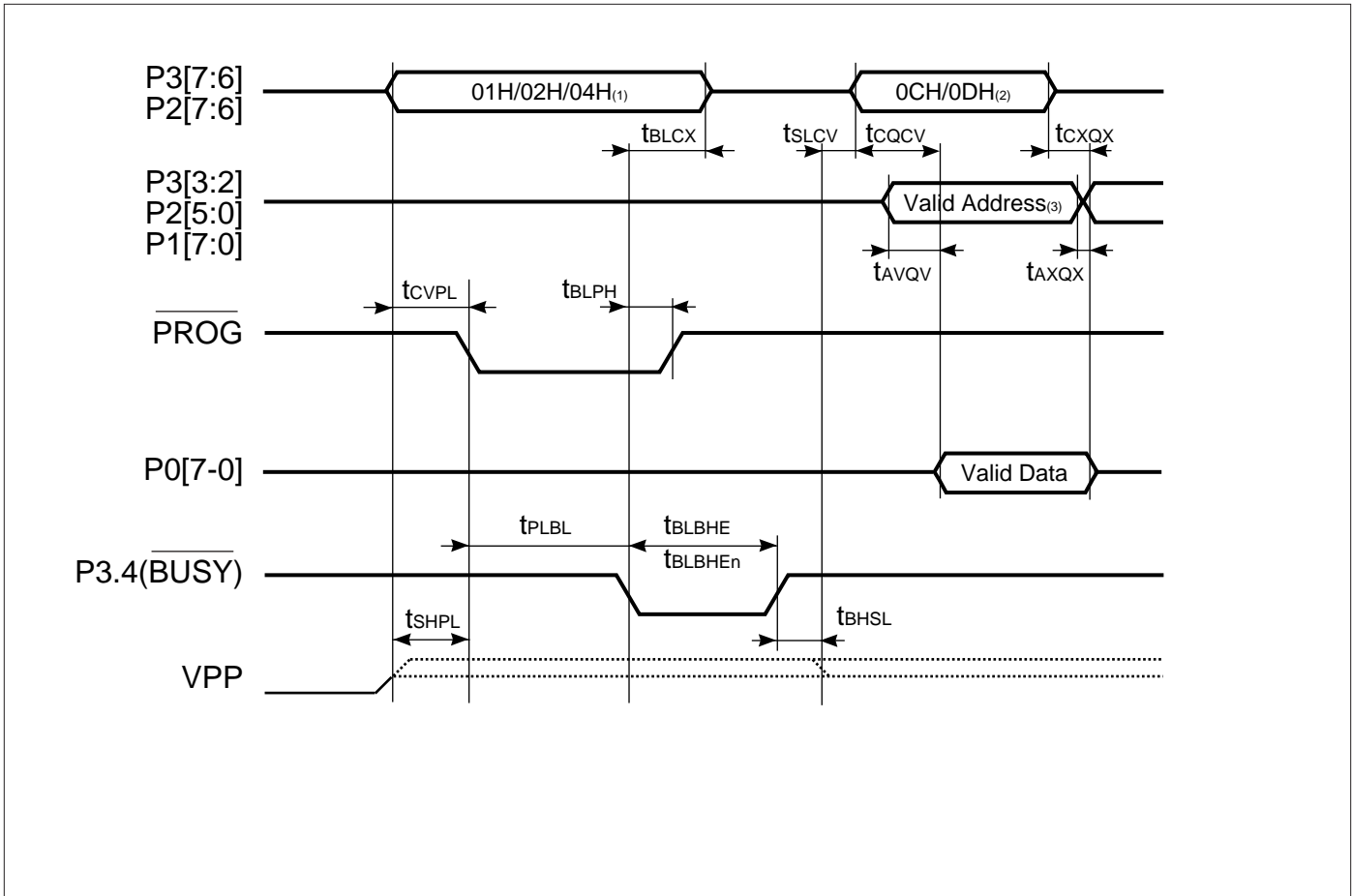

Figure 25. Erasing Timing

Note:

1. 01H/02H/04H are for code Chip Erase/Block 1 Erase/Block2 Erase.
2. 0CH is for code memory verification. 09H is for Lock bits verification.

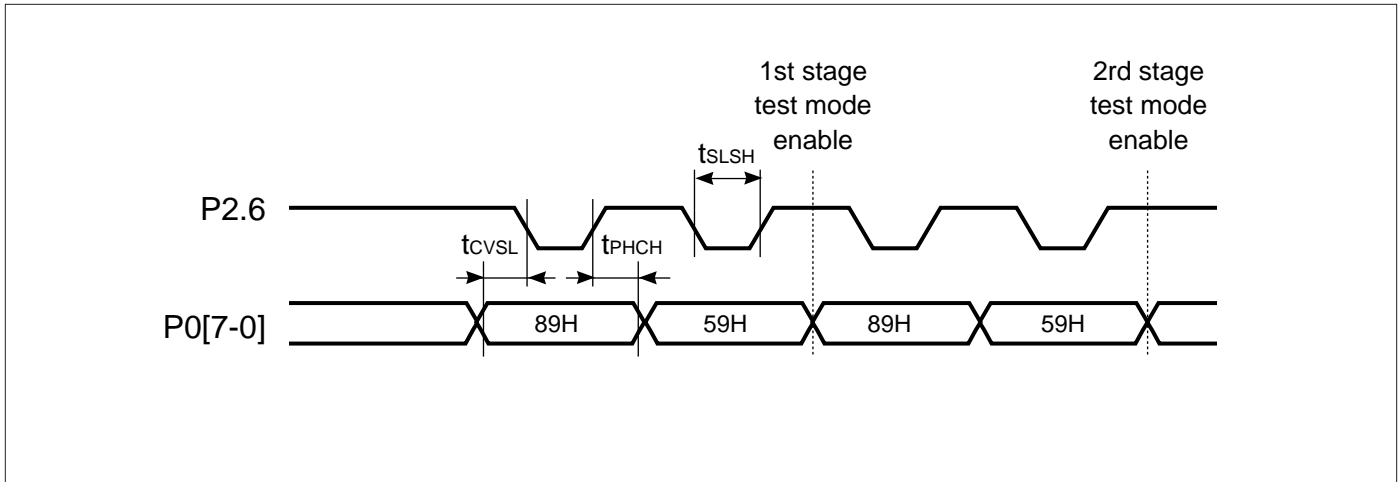

Figure 26. Test Mode Entering Timing

Note:

- EA, PROG, P3.7, P2.7 are high level; P3.6 is lower level.

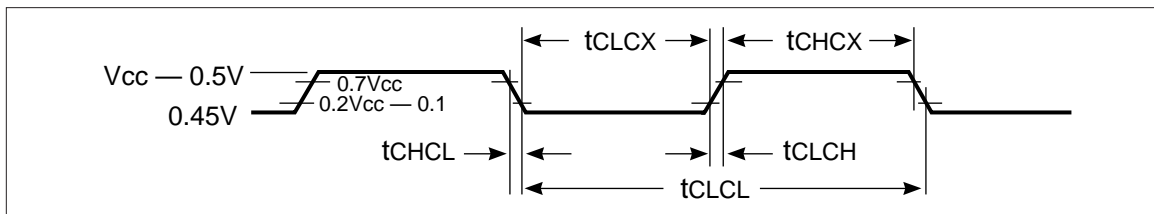

Figure 27. External Clock Drive Waveform

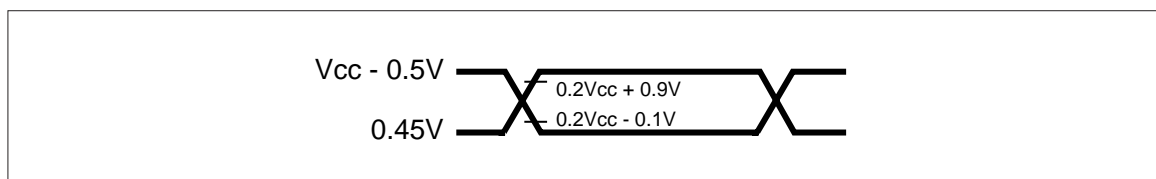

Figure 28. AC Test Point

Note:

- AC inputs during testing are driven at $V_{cc}-0.5V$ for logic "1" and 0.45V for logic "0". Timing measurements are made at V_{ih} min for logic "1" and max for logic "0".

ORDERING INFORMATION
Commercial Range: 0°C to +70°C

Speed	Order Part Number	Package
12 MHz	IC89E54/58/64-12PL	PLCC
	IC89E54/58/64-12W	600mil DIP
	IC89E54/58/64-12PQ	PQFP
24 MHz	IC89E54/58/64-24PL	PLCC
	IC89E54/58/64-24W	600mil DIP
	IC89E54/58/64-24PQ	PQFP
40 MHz	IC89E54/58/64-40PL	PLCC
	IC89E54/58/64-40W	600mil DIP
	IC89E54/58/64-40PQ	PQFP



Integrated Circuit Solution Inc.

HEADQUARTER:

NO.2, TECHNOLOGY RD. V, SCIENCE-BASED INDUSTRIAL PARK,
 HSIN-CHU, TAIWAN, R.O.C.

TEL: 886-3-5780333

Fax: 886-3-5783000

BRANCH OFFICE:

7F, NO. 106, SEC. 1, HSIN-TAI 5TH ROAD,
 HSICHIH TAIPEI COUNTY, TAIWAN, R.O.C.

TEL: 886-2-26962140

FAX: 886-2-26962252

<http://www.icsi.com.tw>