



## Description

The ICS508 is the most cost effective way to generate a high quality, high frequency CMOS clock output from a PECL clock input.

The ICS508 has separate VDD supplies for the PECL input buffer and the output buffer allowing different voltages to be used. For example, the input clock could use a 3.3 V supply while the output operates from 2.5 V.

The device has an Output Enable pin that tri-states the clock output when the OE pin is taken low.

The ICS508 is a member of the ClockBlocks™ family of devices.

## Features

- Packaged as 8 pin SOIC or die
- Separate VDD supplies allow voltage translation
- Clock frequency of 0 - 250 MHz
- Duty cycle of 45/55
- Operating voltages of 2.375 to 5.5 V
- Tri-state output for board level testing
- 24 mA drive capability
- Industrial temperature version available
- Advanced, low power CMOS process



## Block Diagram

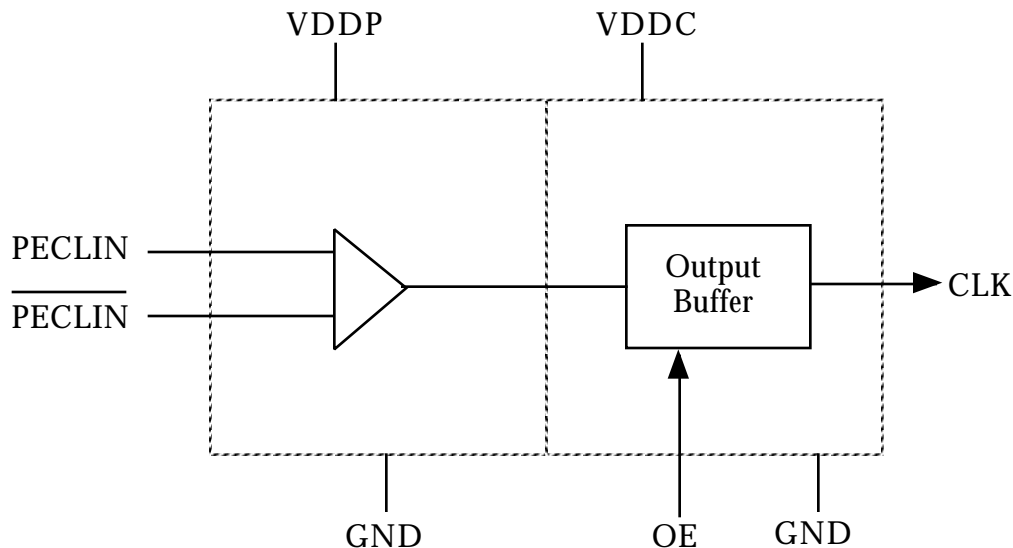

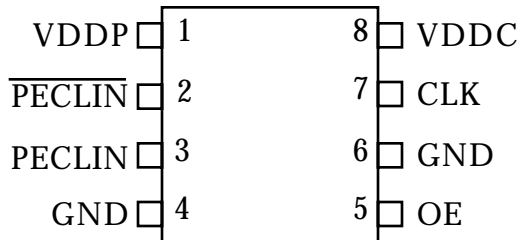
**Pin Assignment****Pin Descriptions**

Number	Name	Type	Description
1	VDDP	O	Connect to 3.3 V or 5 V. Supplies PECL input buffer.
2	$\overline{\text{PECLIN}}$	I	Complementary PECL clock input.
3	PECLIN	I	PECL clock input.
4	GND	P	Connect to ground.
5	OE	I	Output enable. Tri-states CLK output when low. Internal pull-up to VDDC.
6	GND	P	Connect to ground.
7	CLK	O	Clock output.
8	VDDC	P	Connect to 2.5 V, or 3.3 V or 5 V. Supplies output buffer and OE pin.

Key: I = Input, O = output, P = power supply connection



## Electrical Specifications

Parameter	Conditions	Minimum	Typical	Maximum	Units
<b>ABSOLUTE MAXIMUM RATINGS (stresses beyond these can permanently damage the device)</b>					
Supply Voltage, VDDP and VDDC	Referenced to GND			7	V
PECL Inputs	Referenced to GND	-0.5		VDDP+0.5	V
Clock Output and OE Pin	Referenced to GND	-0.5		VDDC+0.5	V
Ambient Operating Temperature		0		70	°C
	ICS508MI only	-40		85	°C
Soldering Temperature	Max of 10 seconds			260	°C
Storage temperature		-65		150	°C
<b>DC CHARACTERISTICS (VDDP = VDDC = 3.3 V unless otherwise noted)</b>					
Operating Voltage, VDDP	Note 1	3		5.5	V
Operating Voltage, VDDC	Note 1	2.375		5.5	V
Peak to Peak Input Voltage, PECLIN		0.3		1	V
Common Mode Range, PECLIN	VDDP = 5 V	VDDP - 3.7		VDDP - 0.6	V
Common Mode Range, PECLIN	VDDP = 3.3 V	VDDP - 2.0		VDDP - 0.6	V
Input High Voltage, VIH	OE only	2		VDDC	V
Input Low Voltage, VIL	OE only			0.8	V
Output High Voltage, VOH	VDDC = 5 V, IOH = -24 mA	VDDC-0.4			V
Output High Voltage, VOL	VDDC = 5 V, IOL = 24 mA			0.4	V
Output High Voltage, VOH	VDDC = 3.3 V, IOH = -18 mA	VDDC-0.4			V
Output High Voltage, VOL	VDDC = 3.3 V, IOL = 18 mA			0.4	V
Output High Voltage, VOH	VDDC = 2.5 V, IOH = -8 mA	VDDC-0.4			V
Output High Voltage, VOL	VDDC = 2.5 V, IOL = 8 mA			0.4	V
On-Chip Pull-up Resistor	OE		250		kΩ
Operating Supply Current, IDDP	100 MHz, no load		1.5		mA
Operating Supply Current, IDDC	100 MHz, no load		8		mA

Note 1: VDDP must always be greater than or equal to VDDC.

**Electrical Specifications**

Parameter	Conditions	Minimum	Typical	Maximum	Units
<b>AC CHARACTERISTICS (VDDP = VDDC = 3.3V unless otherwise noted)</b>					
Input Frequency		0		250	MHz
Output Clock Rise Time, 0.8 to 2 V	VDDC = 5 V		0.4		ns
	VDDC = 3.3 V		0.6		ns
	VDDC = 2.5 V		1		ns
Output Clock Fall Time, 2 V to 0.8 V	VDDC = 5 V		0.4		ns
	VDDC = 3.3 V		0.6		ns
	VDDC = 2.5 V		1		ns
Output Enable Time, OE high to output on			7	20	ns
Output Disable Time, OE low to tri-state			7	20	ns
Propagation Delay	VDDP=5 V, VDDC=5 V		4	6	ns
	VDDP=5 V, VDDC=3.3 V		4.5	7	ns
	VDDP=5 V, VDDC=2.5 V		5.5	9	ns
	VDDP=3.3 V, VDDC=3.3 V		4.5	7	ns
	VDDP=3.3 V, VDDC=2.5 V		5.5	9	ns
Output Clock Duty Cycle, 0-100 MHz	Any VDD combination	45		55	%
Output Clock Duty Cycle, 100-166 MHz	VDDP=5 V, VDDC=5 V	45		55	%
	VDDP=5 V, VDDC=3.3 V	45		55	%
	VDDP=5 V, VDDC=2.5 V	40		60	%
	VDDP=3.3 V, VDDC=3.3 V	40		60	%
	VDDP=3.3 V, VDDC=2.5 V	45		55	%
Output Clock Duty Cycle, 166-250 MHz	VDDP=5 V, VDDC=5 V	40		60	%
	VDDP=5 V, VDDC=3.3 V	40		60	%
	VDDP=5 V, VDDC=2.5 V	35		65	%
	VDDP=3.3 V, VDDC=3.3 V	35		65	%
	VDDP=3.3 V, VDDC=2.5 V	40		60	%



### External Components

The ICS508 requires two 0.01 $\mu$ F decoupling capacitors to be connected between VDDP and GND and between VDDC and GND. They must be connected close to the ICS508 to minimize lead inductance. A 33  $\Omega$  series terminating resistor can be used next to the CLK pin.

### Package Outline and Package Dimensions

(For current dimensional specifications, see JEDEC Publication No. 95.)

#### 8 pin SOIC

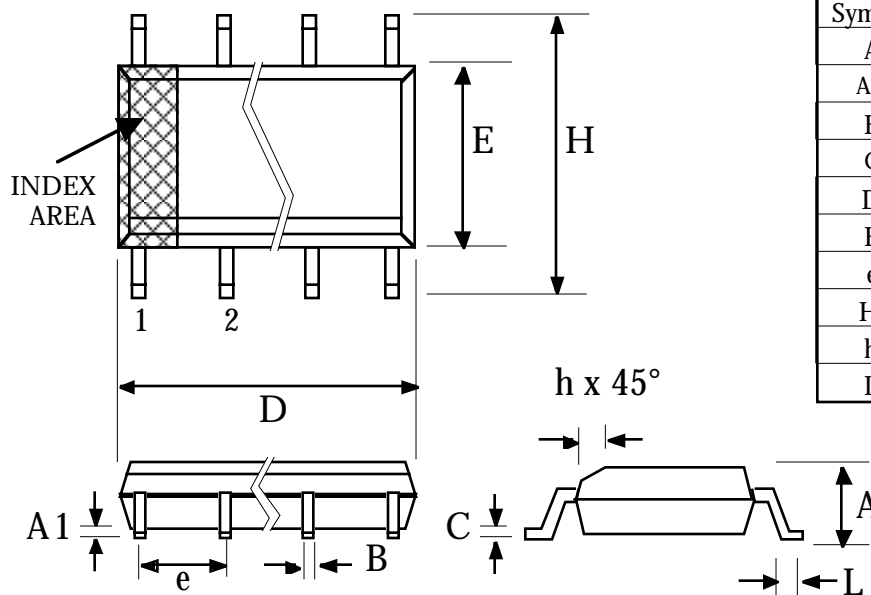

Symbol	Inches		Millimeters	
	Min	Max	Min	Max
A	0.0532	0.0688	1.35	1.75
A1	0.0040	0.0098	0.10	0.24
B	0.0130	0.0200	0.33	0.51
C	0.0075	0.0098	0.19	0.24
D	0.1890	0.1968	4.80	5.00
E	0.1497	0.1574	3.80	4.00
e	.050 BSC		1.27 BSC	
H	0.2284	0.2440	5.80	6.20
h	0.0099	0.0195	0.25	0.50
L	0.0160	0.0500	0.41	1.27

### Ordering Information

Part/Order Number	Marking	Package	Temperature
ICS508M	ICS508M	8 pin SOIC	0 to 70 °C
ICS508MT	ICS508M	8 pin SOIC on tape and reel	0 to 70 °C
ICS508MI	ICS508I	8 pin SOIC	-40 to +85 °C
ICS508MIT	ICS508I	8 pin SOIC on tape and reel	-40 to +85 °C
ICS508-DWF	-	Die on uncut, probed wafers	0 to 70 °C
ICS508-DPK	-	Tested die in waffle pack	0 to 70 °C

While the information presented herein has been checked for both accuracy and reliability, ICS assumes no responsibility for either its use or for the infringement of any patents or other rights of third parties, which would result from its use. No other circuits, patents, or licenses are implied. This product is intended for use in normal commercial applications. Any other applications such as those requiring extended temperature range, high reliability, or other extraordinary environmental requirements are not recommended without additional processing by ICS. ICS reserves the right to change any circuitry or specifications without notice. ICS does not authorize or warrant any ICS product for use in life support devices or critical medical instruments.