

FEATURES

- Dual Version of SFH610 Series
- High Current Transfer Ratios
 - ILD610-1, 40-80%
 - ILD610-2, 63-125%
 - ILD610-3, 100-200%
 - ILD610-4, 160-320%
- Isolation Test Voltage, 5300 V_{RMS}
- V_{CEsat} 0.25 (≤0.4) V at I_F=10 mA, I_C=2.5 mA
- V_{CEO}=70 V
- Underwriters Lab File #E52744
- VDE #0884 Available with Option 1

DESCRIPTION

The ILD610 Series is a dual channel optocoupler series for high density applications. Each channel consists of an optically coupled pair with a Gallium Arsenide infrared LED and a silicon NPN phototransistor. Signal information, including a DC level, can be transmitted by the device while maintaining a high degree of electrical isolation between input and output. The ILD610 Series is the dual version of SFH610 Series and uses a repetitive pin-out configuration instead of the more common alternating pin-out used in most dual couplers.

Maximum Ratings (Each Channel)

Emitter

Reverse Voltage 6.0 V
 Surge Forward Current (t ≤10 ms) 1.5 A
 Total Power Dissipation 100 mW
 Derate Linearly from 25°C 1.3 mW/°C
 DC Forward Current 60 mA

Detector

Collector-Emitter Voltage 70 V
 Collector Current 50 mA
 Collector Current (t ≤1.0 ms) 100 mA
 Total Power Dissipation 150 mW
 Derate Linearly from 25°C 2.0 mW/°C

Package

Isolation Test Voltage (t=1.0 sec.) 5300 V_{RMS}
 Isolation Resistance
 V_{IO}=500 V, T_A=25°C ≥10¹² Ω
 V_{IO}=500 V, T_A=100°C ≥10¹¹ Ω
 Storage Temperature -55°C to +150°C
 Operating Temperature -55°C to +100°C
 Junction Temperature 100°C
 Lead Soldering Time at 260°C 10 sec.

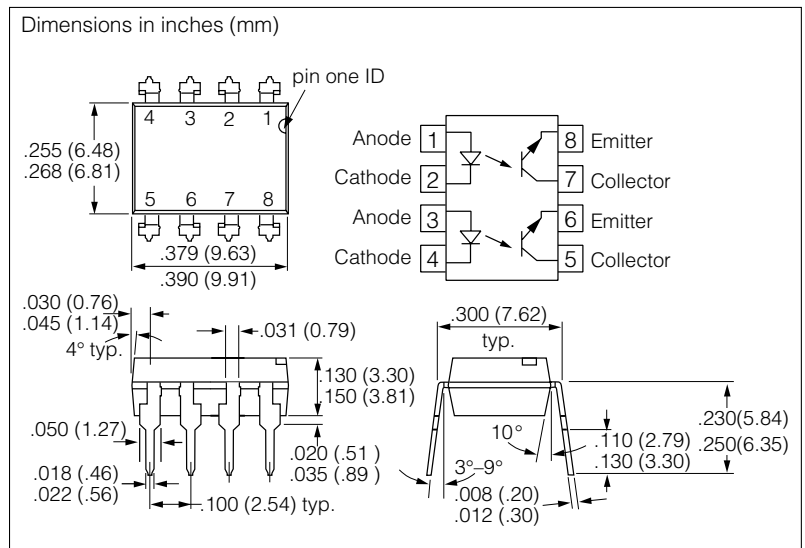

Electrical Characteristics T_A=25°C

	Symbol	Typ.	Unit	Condition
Emitter				
Forward Voltage	V _F	1.25 (≤1.65)	V	I _F =60mA
Reverse Current	I _R	0.01 (≤10)	μA	V _R =6.0 V
Capacitance	C _O	25	pF	V _R =0 V f=1.0 MHz
Detector				
Breakdown Voltage	BV _{CEO}	90 (≥70)	V	I _C =10 mA I _E =10 μA
	BV _{CEO}	7.0 (≥6.0)		
Collector-Emitter Dark Current	I _{CEO}	2.0 (≤50)	nA	V _{CE} =10 V
Capacitance	C _{CE}	7.0	pF	V _{CE} =5.0 V f=1.0 MHz
Package				
Collector-Emitter Saturation Voltage	V _{CEsat}	0.25 (≤0.40)	V	I _F =10 mA I _C =2.5 mA
Coupling Capacitance	C _C	0.35	pF	—

	-1	-2	-3	-4	
CTR ¹ , I _F =10 mA, V _{CE} =5.0 V	40-80	63-125	100-200	160-320	%
CTR ¹ , I _F =1.0 mA, V _{CE} =5.0 V	13 min.	22 min.	34 min.	56 min.	%
I _{CEO} (V _{CE} =10 V)	2.0 (≤50)	2.0 (≤50)	5.0 (≤100)	5.0 (≤100)	nA

CTR will match within a ratio of 1.7:1

Switching Characteristics

Linear Operation (without saturation) I_F=10 mA, V_{CC}=5.0 V, R_C=75 Ω, Typical

		-1	-2	-3	-4	
Turn on time	t _{on}	3.0	3.2	3.6	4.1	μs
Rise time	t _r	2.0	2.5	2.9	3.3	μs
Turn off time	t _{off}	2.3	2.9	3.4	3.7	μs
Fall time	t _f	2.0	2.6	3.1	3.5	μs

Switching Operation (with saturation) V_{CC}=5.0 V, R_C=1.0 Ω, Typical

		-1 I _F = 20 mA	-2 I _F = 10 mA	-3 I _F = 10 mA	-4 I _F = 5.0 mA	
Turn on time	t _{on}	3.0	4.3	4.6	6.0	μs
Rise time	t _r	2.0	2.8	3.3	4.6	μs
Turn off time	t _{off}	18	2.9	3.4	25	μs
Fall time	t _f	11	2.6	3.1	15	μs

Figure 1. Forward voltage versus forward current

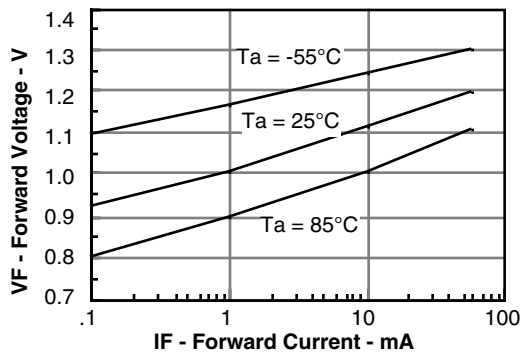

Figure 3. Normalized non-saturated and saturated CTR at T_A=50°C versus LED current

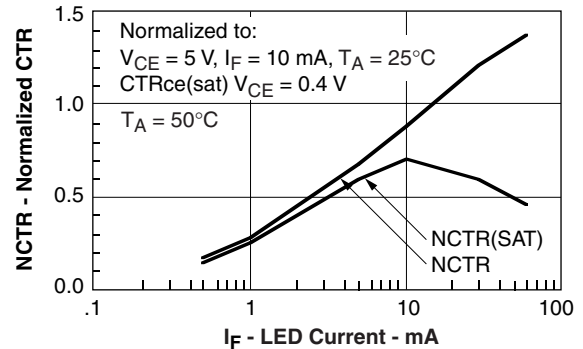

Figure 2. Normalized non-saturated and saturated CTR at T_A=25°C versus LED current

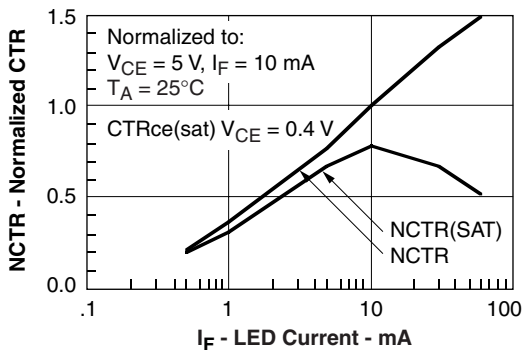

Figure 4. Normalized non-saturated and saturated CTR at T_A=70°C versus LED current

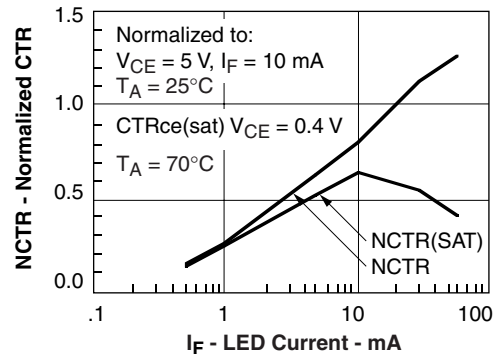

Figure 5. Normalized non-saturated and saturated CTR at $T_A=85^\circ\text{C}$ versus LED current

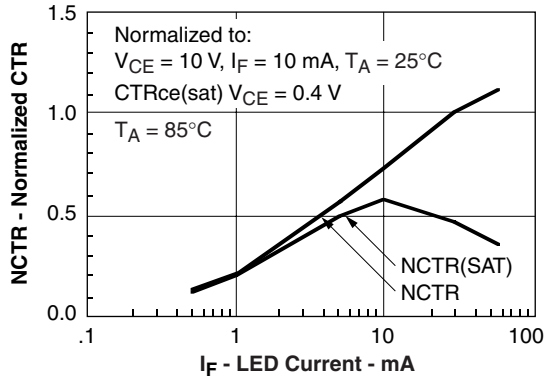

Figure 6. Collector-emitter current versus temperature and LED current

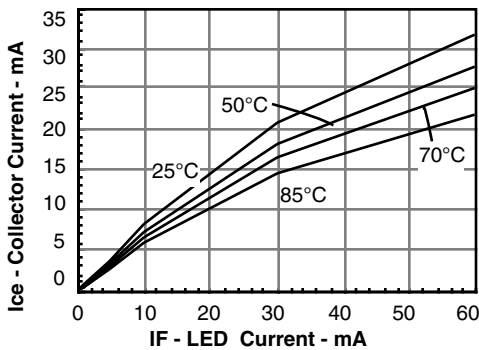

Figure 7. Collector-emitter leakage current versus temperature

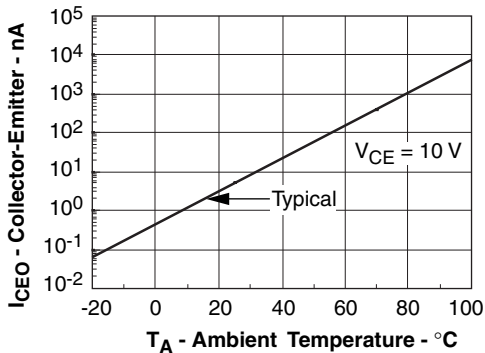

Figure 8. Propagation delay versus collector load resistor

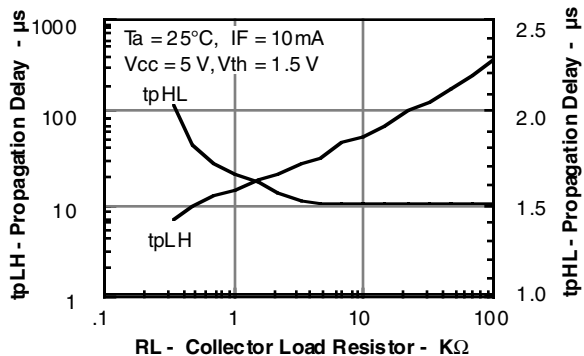

Figure 9. Switching timing

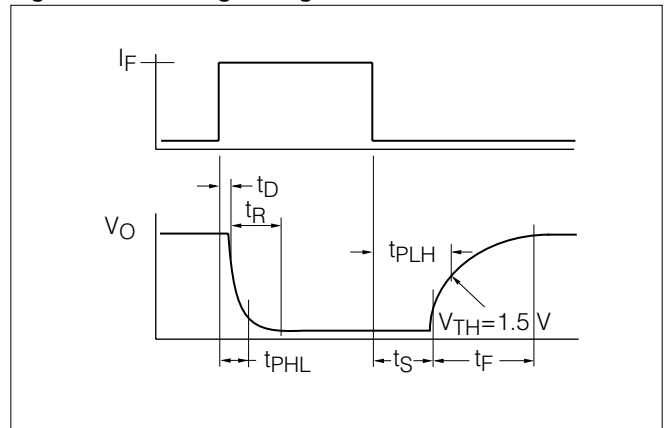

Figure 10. Non-saturated switching schematic

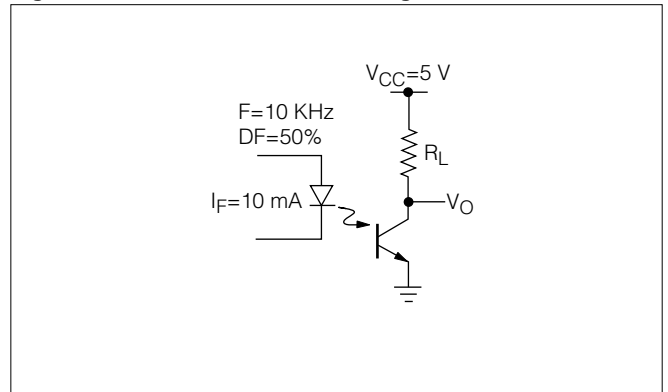

Figure 11. Saturated switching time test waveform

