



DUAL CHANNEL ILD615 QUAD CHANNEL ILQ615 Phototransistor Optocoupler

FEATURES

- **Identical Channel to Channel Footprint**
- **Current Transfer Ratio (CTR) Range, $I_F=10$ mA**
 ILD/Q615-1: 40–80% Min.
 ILD/Q615-2: 63–125% Min.
 ILD/Q615-3: 100–200% Min.
 ILD/Q615-4: 160–320% Min.
- **Guaranteed CTR, $I_F=1.0$ mA**
 ILD/Q615-1: 13% Min.
 ILD/Q615-2: 22% Min.
 ILD/Q615-3: 34% Min.
 ILD/Q615-4: 56% Min.
- **High Collector-Emitter Voltage, $BV_{CEO}=70$ V**
- **Dual and Quad Packages Feature:**
 - Reduced Board Space
 - Lower Pin and Parts Count
 - Better Channel to Channel CTR Match
 - Improved Common Mode Rejection
- **Field-Effect Stable by TRIOS (TRansparent IO n Shield)**
- **Isolation Test Voltage from Double Molded Package, 5300 V_{RMS}**
- **UL Approval #E52744**
- **VDE #0884 Available with Option 1**

Maximum Ratings (Each Channel)

Emitter

Reverse Voltage	6.0 V
Forward Current	60 mA
Surge Current	1.5 A
Power Dissipation	100 mW
Derate Linearly from 25°C	1.33 mW/°C

Detector

Collector-Emitter Reverse Voltage	70 V
Emitter-Collector Reverse Voltage	7.0 V
Collector Current	50 mA
Collector Current (t < 1.0 ms)	100 mA
Power Dissipation	150 mW
Derate Linearly from 25°C	2.0 mW/°C

Package

Storage Temperature	–55°C to +150°C
Operating Temperature	–55°C to +100°C
Junction Temperature	100°C
Soldering Temperature (2.0 mm distance from case bottom)	260°C
Package Power Dissipation, ILD615	400 mW
Derate Linearly from 25°C	5.33 mW/°C
Package Power Dissipation, ILQ615	500 mW
Derate Linearly from 25°C	6.67 mW/°C
Isolation Test Voltage (t=1.0 sec.)	5300 V _{RMS}
Creepage	≥7.0 mm
Clearance	≥7.0 mm
Isolation Resistance $V_{IO}=500$ V, $T_A=25$ °C	≥10 ¹² Ω
$V_{IO}=500$ V, $T_A=100$ °C	≥10 ¹¹ Ω

Dimensions in inches (mm)

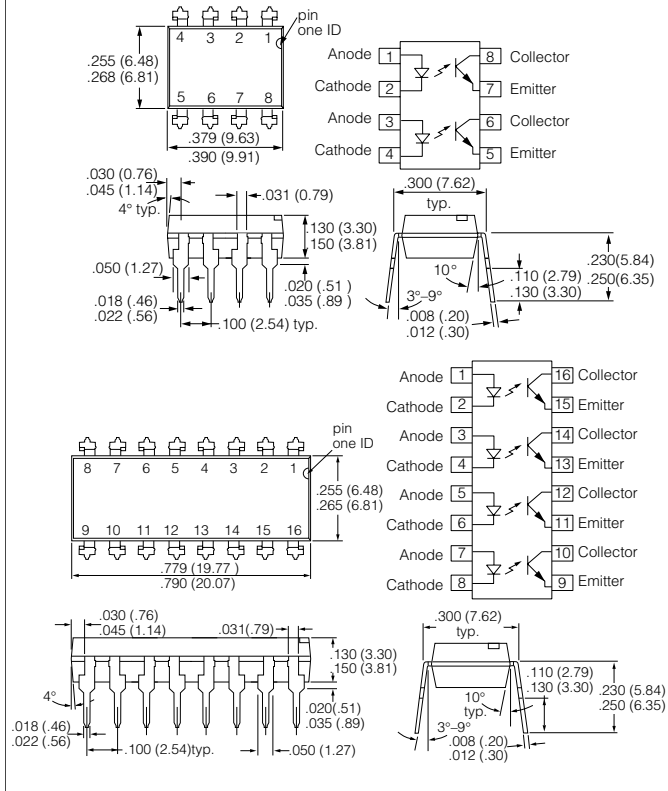

DESCRIPTION

The ILD/Q615 are multi-channel phototransistor optocouplers that use GaAs IRLED emitters and high gain NPN phototransistors. These devices are constructed using over/under leadframe optical coupling and double molded insulation technology resulting a Withstand Test Voltage of 7500 V_{AC}PEAK and a Working Voltage of 1700 V_{RMS}.

The binned min./max. and linear CTR characteristics combined with the TRIOS (TRansparent IO n Shield) field-effect process make these devices well suited for DC or AC voltage detection. Eliminating the phototransistor base connection provides added electrical noise immunity from the transients found in many industrial control environments.

Because of guaranteed maximum non-saturated and saturated switching characteristics, the ILD/Q615 can be used in medium speed data I/O and control systems. The binned min./max. CTR specification allow easy worst case interface calculations for both level detection and switching applications. Interfacing with a CMOS logic is enhanced by the guaranteed CTR at $I_F=1.0$ mA.

See Appnote 45, "How to Use Optocoupler Normalized Curves".

Characteristics $T_A=25^\circ\text{C}$

	Symbol	Min.	Typ.	Max.	Unit	Condition
Emitter						
Forward Voltage	V_F	1.0	1.15	1.3	V	$I_F=10\text{ mA}$
Breakdown Voltage	V_{BR}	6.0	30	—	V	$I_R=10\ \mu\text{A}$
Reverse Current	I_R	—	0.01	10	μA	$V_R=6.0\text{ V}$
Capacitance	C_O	—	25	—	pF	$V_R=0\text{ V}$, $f=1.0\text{ MHz}$
Thermal Resistance, Junction to Lead	R_{THJL}	—	750	—	K/W	—
Detector						
Capacitance	C_{CE}	—	6.8	—	pF	$V_{CE}=5.0\text{ V}$, $f=1.0\text{ MHz}$
Collector-Emitter Leakage Current, -1, -2	I_{CEO}	—	2.0	50	nA	$V_{CE}=10\text{ V}$
Collector-Emitter Leakage Current, -3, -4	I_{CEO}	—	5.0	100	nA	$V_{CE}=10\text{ V}$
Collector-Emitter Breakdown Voltage	BV_{CEO}	70	—	—	V	$I_{CE}=0.5\text{ mA}$
Emitter-Collector Breakdown Voltage	BV_{ECO}	7.0	—	—	V	$I_E=0.1\text{ mA}$
Thermal Resistance, Junction to Lead	R_{THJL}	—	500	—	K/W	—
Package Transfer Characteristics	—	—	—	—	—	—
Channel/Channel CTR Match	CTR _X /CTR _Y	1 to 1	—	2 to 1	—	$I_F=10\text{ mA}$, $V_{CE}=5.0\text{ V}$
ILD/Q615-1						
Saturated Current Transfer Ratio	CTR _{CEsat}	—	25	—	%	$I_F=10\text{ mA}$, $V_{CE}=0.4\text{ V}$
Current Transfer Ratio	CTR _{CE}	40	60	80	%	$I_F=10\text{ mA}$, $V_{CE}=5.0\text{ V}$
Current Transfer Ratio	CTR _{CE}	13	30	—	%	$I_F=1.0\text{ mA}$, $V_{CE}=5.0\text{ V}$
ILD/Q615-2						
Saturated Current Transfer Ratio	CTR _{CEsat}	—	40	—	%	$I_F=10\text{ mA}$, $V_{CE}=0.4\text{ V}$
Current Transfer Ratio	CTR _{CE}	63	80	125	%	$I_F=10\text{ mA}$, $V_{CE}=5.0\text{ V}$
Current Transfer Ratio	CTR _{CE}	22	45	—	%	$I_F=1.0\text{ mA}$, $V_{CE}=5.0\text{ V}$
ILD/Q615-3						
Saturated Current Transfer Ratio	CTR _{CEsat}	—	60	—	%	$I_F=10\text{ mA}$, $V_{CE}=0.4\text{ V}$
Current Transfer Ratio	CTR _{CE}	100	150	200	%	$I_F=10\text{ mA}$, $V_{CE}=5.0\text{ V}$
Current Transfer Ratio	CTR _{CE}	34	70	—	%	$I_F=1.0\text{ mA}$, $V_{CE}=5.0\text{ V}$
ILD/Q615-4						
Saturated Current Transfer Ratio	CTR _{CEsat}	—	100	—	%	$I_F=10\text{ mA}$, $V_{CE}=0.4\text{ V}$
Current Transfer Ratio	CTR _{CE}	160	200	320	%	$I_F=10\text{ mA}$, $V_{CE}=5.0\text{ V}$
Current Transfer Ratio	CTR _{CE}	56	90	—	%	$I_F=1.0\text{ mA}$, $V_{CE}=5.0\text{ V}$
Isolation and Insulation						
Common Mode Rejection, Output High	CMH	—	5000	—	V/ μs	$V_{CM}=50\text{ V}_{P-P}$, $R_L=1.0\text{ k}\Omega$, $I_F=0\text{ mA}$
Common Mode Rejection, Output Low	CML	—	5000	—	V/ μs	$V_{CM}=50\text{ V}_{P-P}$, $R_L=1.0\text{ k}\Omega$, $I_F=10\text{ mA}$
Common Mode Coupling Capacitance	C_{CM}	—	0.01	—	pF	—
Package Capacitance	C_{I-O}	—	0.8	—	pF	$V_{I-O}=0\text{ V}$, $f=1.0\text{ MHz}$
Insulation Resistance	R_S	10^{12}	10^{14}	—	Ω	$V_{I-O}=500\text{ V}$, $T_A=25^\circ\text{C}$
Channel to Channel Isolation	—	500	—	—	VAC	—

SWITCHING TIMES

Figure 1. Non-saturated switching timing

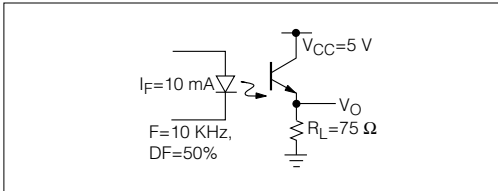

Figure 2. Saturated switching timing

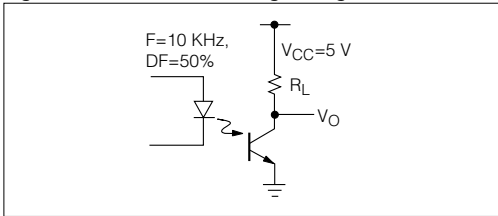

Figure 3. Non-saturated switching timing

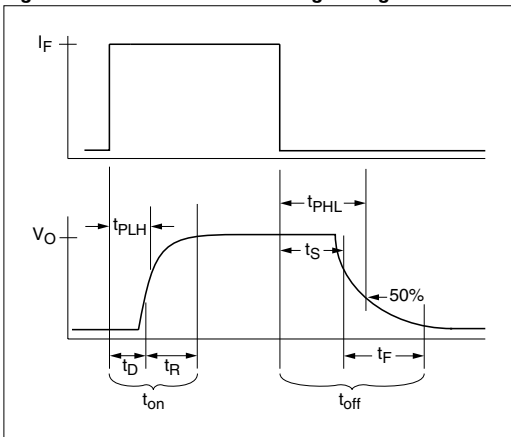
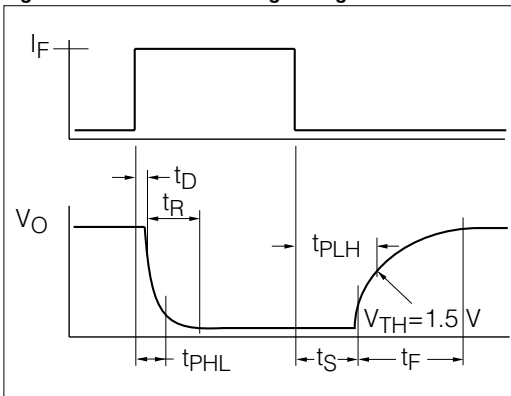

Figure 4. Saturated switching timing



Parameter	Typ.	Unit	Test Condition
t_{ON}	3.0	μs	$R_L = 75 \Omega$ $I_F = 10 \text{ mA}$ $V_{CC} = 5.0 \text{ V}$
t_r	2.0	μs	
t_{OFF}	2.3	μs	
t_f	2.0	μs	
t_{PHL} Propagation H-L (50% of V_{PP})	1.1	μs	
t_{PHL} Propagation L-H	2.5	μs	

Parameter	-1 $I_F = 20 \text{ mA}$	-2,-3 $I_F = 10 \text{ mA}$	-4 $I_F = 5.0 \text{ mA}$	Unit	Test Condition
	Typ.	Typ.	Typ.		
t_{ON}	3.0	4.3	6.0	μs	$R_L = 1.0 \text{ K}\Omega$ $V_{CC} = 5.0 \text{ V}$ $V_{TH} = 1.5 \text{ V}$
t_r	2.0	2.8	4.6	μs	
t_{OFF}	18	25	25	μs	
t_f	11	14	15	μs	
t_{PHL} Propagation H-L	1.6	2.6	5.4	μs	
t_{PLH} Propagation L-H	8.6	7.2	7.4	μs	

Figure 5. Maximum LED current versus ambient temperature

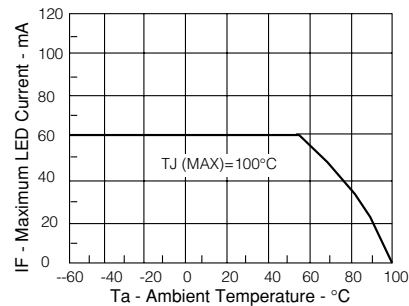

Figure 6. Maximum LED power dissipation

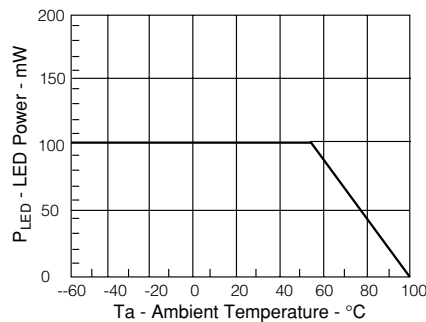

Figure 7. Forward voltage versus forward current

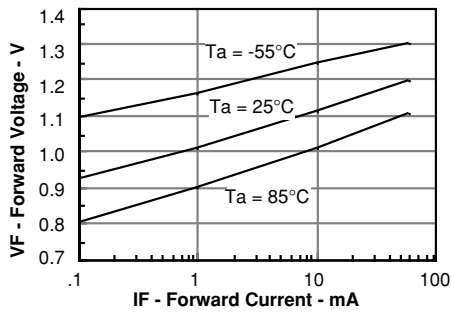

Figure 8. Peak LED current versus pulse detection, Tau

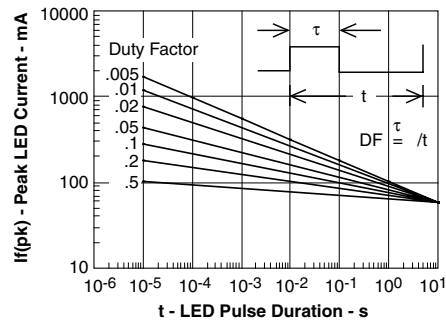

Figure 9. Maximum detector power dissipation

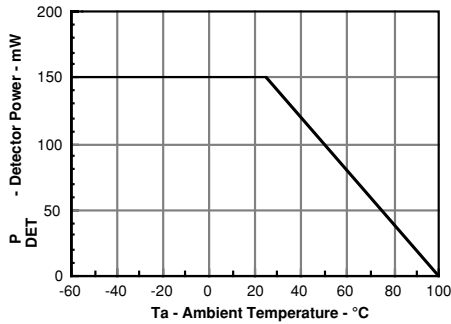

Figure 10. Maximum collector current versus collector voltage

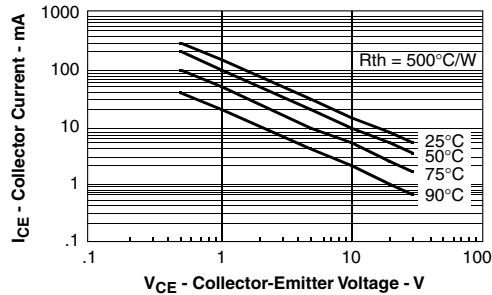

Figure 11. Normalization factor for non-saturated and saturated CTR TA=25°C versus IF

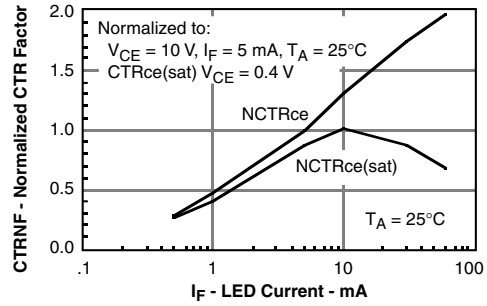

Figure 12. Normalization factor for non-saturated and saturated CTR TA=50°C versus IF

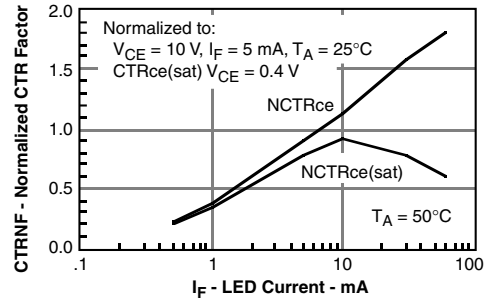

Figure 13. Normalization factor for non-saturated and saturated CTR TA=70°C versus IF

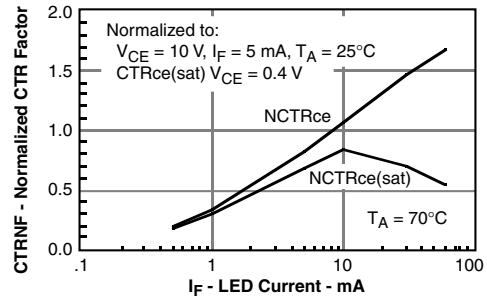

Figure 14. Normalization factor for non-saturated and saturated CTR TA=85°C versus IF

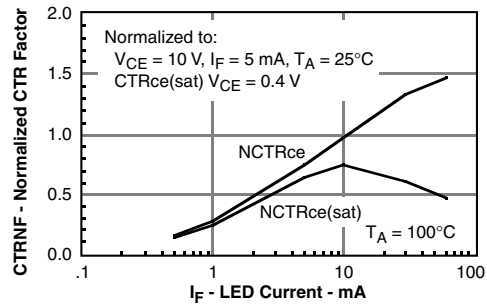

Figure 15. Collector-emitter current versus temperature and LED current

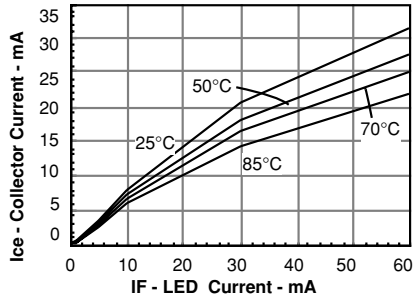

Figure 16. Collector-emitter leakage versus temperature

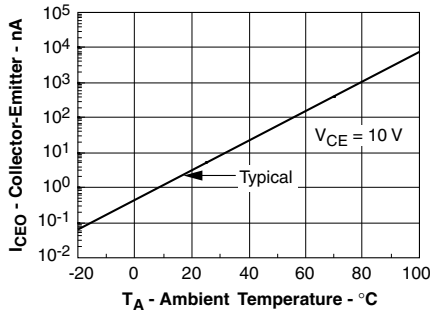

Figure 17. -1 Propagation delay versus collector load resistor

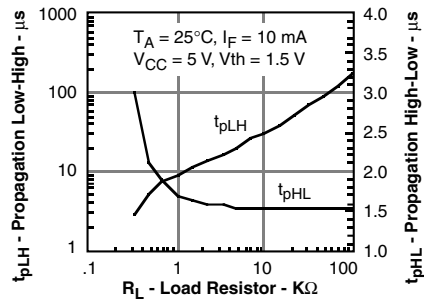

Figure 18. -2, -3 Propagation delay versus collector load resistor

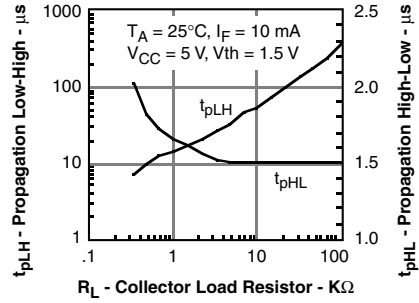

Figure 19. -4 Propagation delay versus collector load resistor

