

IN74LS86

Quad 2-Input Exclusive OR Gate

This device contains four independent 2-input Exclusive-OR gates. It performs the Boolean functions $Y=A \oplus B=AB+\overline{A}\overline{B}$ in positive logic.

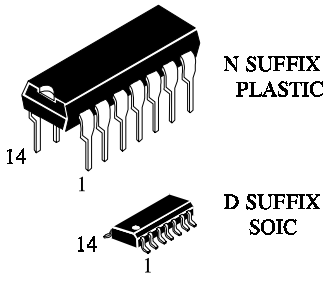

ORDERING INFORMATION
 IN74LS86N Plastic
 IN74LS86D SOIC
 $T_A = 0^\circ$ to 70° C for all packages

LOGIC DIAGRAM

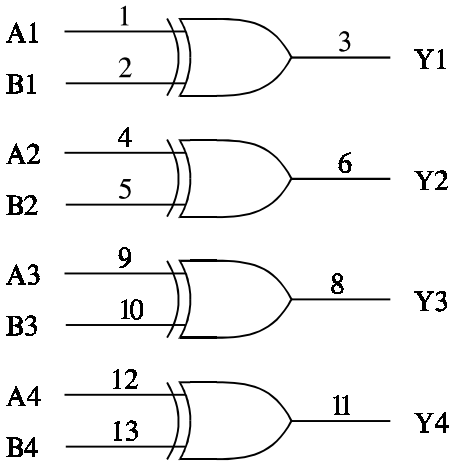

PIN 14 = V_{CC}
 PIN 7 = GND

PIN ASSIGNMENT

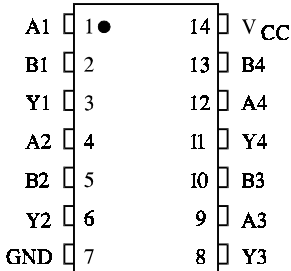

FUNCTION TABLE

Inputs		Output
A	B	Y
L	L	L
L	H	H
H	L	H
H	H	L

MAXIMUM RATINGS*

Symbol	Parameter	Value	Unit
V _{CC}	Supply Voltage	7.0	V
V _{IN}	Input Voltage	7.0	V
V _{OUT}	Output Voltage	5.5	V
T _{stg}	Storage Temperature Range	-65 to +150	°C

*Maximum Ratings are those values beyond which damage to the device may occur. Functional operation should be restricted to the Recommended Operating Conditions.

RECOMMENDED OPERATING CONDITIONS

Symbol	Parameter	Min	Max	Unit
V _{CC}	Supply Voltage	4.75	5.25	V
V _{IH}	High Level Input Voltage	2.0		V
V _{IL}	Low Level Input Voltage		0.8	V
I _{OH}	High Level Output Current		-0.4	mA
I _{OL}	Low Level Output Current		8.0	mA
T _A	Ambient Temperature Range	0	+70	°C

DC ELECTRICAL CHARACTERISTICS over full operating conditions

Symbol	Parameter		Test Conditions	Guaranteed Limit		Unit
				Min	Max	
V _{IK}	Input Clamp Voltage		V _{CC} = min, I _{IN} = -18 mA		-1.5	V
V _{OH}	High Level Output Voltage		V _{CC} = min, I _{OH} = -0.4 mA	2.7		V
V _{OL}	Low Level Output Voltage		V _{CC} = min, I _{OL} = 4 mA		0.4	V
			V _{CC} = min, I _{OL} = 8 mA		0.5	
I _{IH}	High Level Input Current		V _{CC} = max, V _{IN} = 2.7 V		40	μA
			V _{CC} = max, V _{IN} = 7.0 V		0.2	mA
I _{IL}	Low Level Input Current		V _{CC} = max, V _{IN} = 0.4 V		-0.8	mA
I _O	Output Short Circuit Current		V _{CC} = max, V _O = 0 V (Note 1)	-20	-100	mA
I _{CC}	Supply Current	Total with outputs high	V _{CC} = max		10	mA
		Total with outputs low			15	

Note 1: Not more than one output should be shorted at a time, and duration should not exceed one second.

AC ELECTRICAL CHARACTERISTICS ($T_A=25^\circ\text{C}$, $V_{CC} = 5.0\text{ V}$, $C_L = 15\text{ pF}$, $R_L = 2\text{ k}\Omega$, $t_r=15\text{ ns}$, $t_f = 6.0\text{ ns}$)

Symbol	Parameter	Min	Max	Unit
t_{PLH}	Propagation Delay, Input A or B to Output Y (Other input low)		23	ns
t_{PHL}	Propagation Delay, Input A or B to Output Y (Other input low)		17	ns
t_{PLH}	Propagation Delay, Input A or B to Output Y (Other input high)		30	ns
t_{PHL}	Propagation Delay, Input A or B to Output Y (Other input high)		22	ns

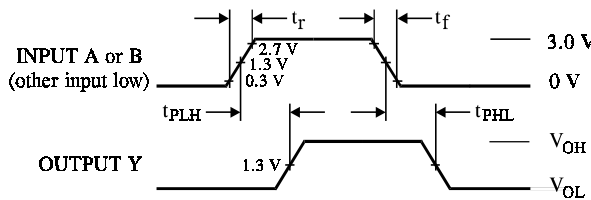

Figure 1. Switching Waveforms

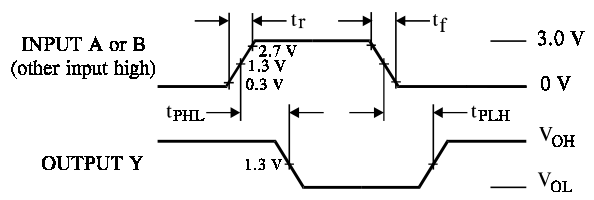
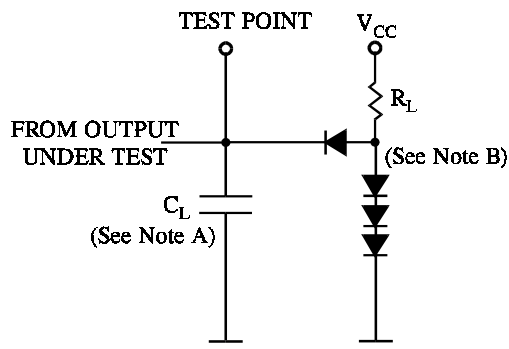

Figure 2. Switching Waveforms



NOTES A. C_L includes probe and jig capacitance.
 B. All diodes are 1N916 or 1N3064.

Figure 3. Test Circuit