

TOP VIEW

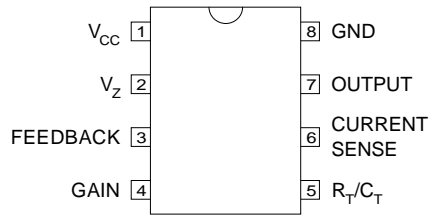

J Package – 8 Pin Ceramic DIP
N Package – 8 Pin Plastic DIP
D Package – 8 Pin Plastic (150) SOIC

BLOCK DIAGRAM

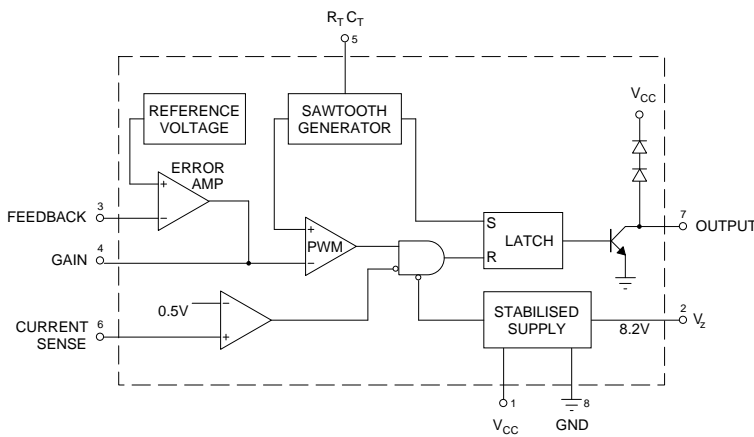

**SWITCHED-MODE
POWER SUPPLY
CONTROL CIRCUIT**

FEATURES

- STABILISED POWER SUPPLY
- TEMPERATURE COMPENSATED REFERENCE SOURCE
- SAWTOOTH GENERATOR
- PULSE WIDTH MODULATOR
- CURRENT LIMITING
- 8 PIN DIP

DESCRIPTION

The IP5561 is a control circuit for use in switched mode power supplies. This single monolithic chip incorporates all the control and supervisory (protection) functions required in switched mode power supplies, including an internal temperature compensated reference source, internal zener reference, sawtooth generator, pulse width modulator, output stage and cycle by cycle current limit.

Order Information

Part Number	J-Pack 8 Pin	N-Pack 8 Pin	D-8 8 Pin	Temp. Range	Note:
IP5561	✓			-55 to +125°C	To order, add the package identifier to the part number. eg. IP5561J IP5561CD-8
IP5561C	✓	✓	✓	0 to +70°C	

ABSOLUTE MAXIMUM RATINGS ($T_{case} = 25^{\circ}C$ unless otherwise stated)

SUPPLY		
Voltage Sourced		18V
Current Sourced		30mA
OUTPUT TRANSISTOR		
Output Current		40mA
Collector Voltage	(Pin 7)	18V
T_J	Operating Junction Temperature	See Ordering Information
T_{STG}	Storage Temperature Range	-55 to +150°C

ELECTRICAL CHARACTERISTICS ($T_J = 25^\circ\text{C}$ unless otherwise stated)

Parameter	Test Conditions	IP5561			IP5561C			Units
		Min.	Typ.	Max.	Min.	Typ.	Max.	
REFERENCE SECTIONS								
Internal Reference Voltage (V_{REF})	$T_J = \text{Over Temp. Range}$	3.69	3.75	3.84	3.57	3.75	3.96	V
		3.65		3.88	3.55		3.98	
Temperature Coefficient of V_{REF}		± 100			± 100			ppm/ $^\circ\text{C}$
Internal Reference (V_Z)	$I_L = -7\text{mA}$	7.8	8.2	8.8	7.8	8.2	8.8	V
Temperature Coefficient of V_Z		± 200			± 200			ppm/ $^\circ\text{C}$
OSCILLATOR SECTION								
Frequency Range	$T_J = \text{Over Temp. Range}$	50		100k	50		100k	Hz
Initial Accuracy Oscillator	$f_O = 20\text{kHz}$	12			12			%
Duty Cycle Range		0-90	0-98		0-90	0-98		
CURRENT LIMITING								
I_{IN}	$V_{pin6} = 250\text{mV}$ $T_J = \text{Over Temp. Range}$	-2	-10		-2	-10		μA
			-20			-20		
Single Pulse Inhibit Delay	Inhibit Delay Time for 20% overdrive	$I_{OUT} = 20\text{mA}$		0.88	1.10	$I_{OUT} = 20\text{mA}$		μs
		$I_{OUT} = 40\text{mA}$		0.7	0.8	$I_{OUT} = 40\text{mA}$		
Current Limit Trip Level		0.40	0.50	0.60	0.40	0.50	0.60	V
ERROR AMPLIFIER								
Output Voltage Swing (V_{OH})		6.2			6.2			V
Output Voltage Swing (V_{OL})		0.7			0.7			
Open Loop Gain		60			60			dB
Feedback Resistor		10k			10k			Ω
Small Signal Bandwidth		3			3			MHz
OUTPUT STAGE								
$V_{CE(sat)}$	$I_C = 20\text{mA}$ $T_J = \text{Over Temp. Range}$	0.4			0.4			V
Output Current	$T_J = \text{Over Temp. Range}$	20			20			mA
SUPPLY VOLTAGE/CURRENT								
Supply Current (I_{CC})	$I_Z = 0$, Voltage Fed $T_J = \text{Over Temp. Range}$	10			10			mA
		13			13			
Supply Voltage (V_{CC})	$I_{CC} = 10\text{mA}$, Voltage Fed	20	21	22	19	21	24	V
	$I_{CC} = 30\text{mA}$, Voltage Fed	20		30	20		30	
LOW SUPPLY PROTECTION								
Pin 1 Threshold		8	9	10.5	8	9	10.5	V

NOTES

- 1) Test Conditions: $V_{CC} = 12\text{V}$, $T_J = 25^\circ\text{C}$ unless otherwise stated
- 2) Tests marked $T_J = \text{Over Temp. Range}$ apply over the full temperature range
 - ie. $T_J = -55$ to $+125^\circ\text{C}$ for IP5561
 - $T_J = 0$ to $+70^\circ\text{C}$ for IP5561C

TYPICAL PERFORMANCE CHARACTERISTICS — ERROR AMPLIFIER

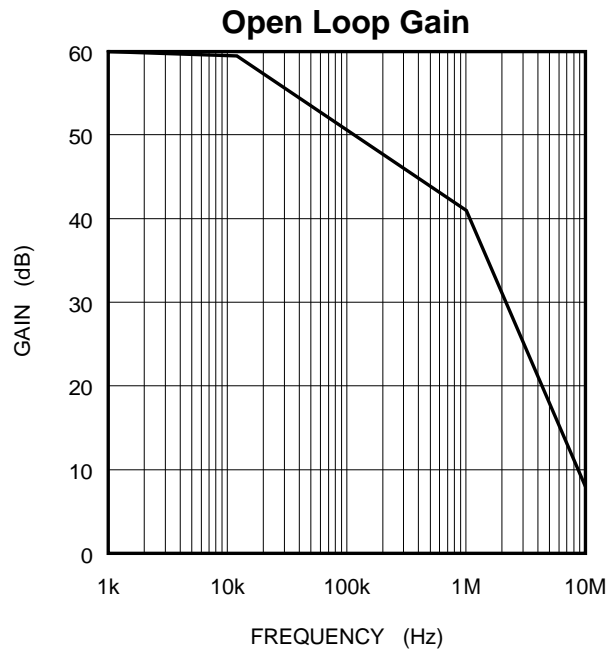
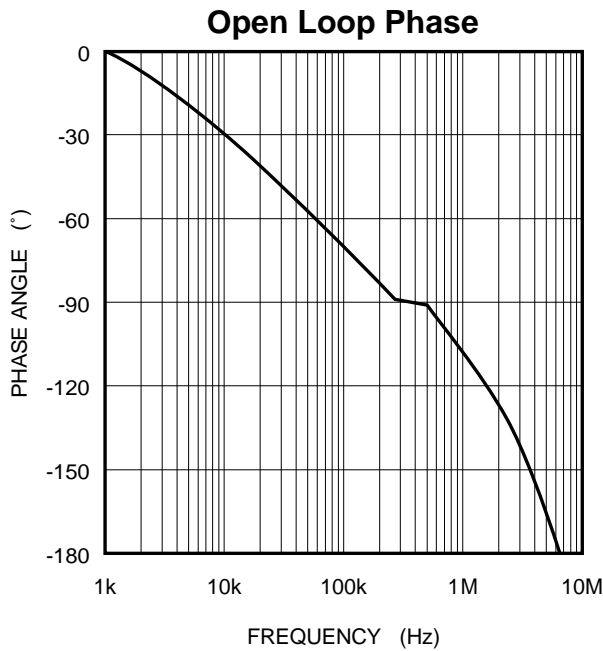

**Transfer Curve of Pulse Width Modulator
Duty Cycle vs Input Voltage**

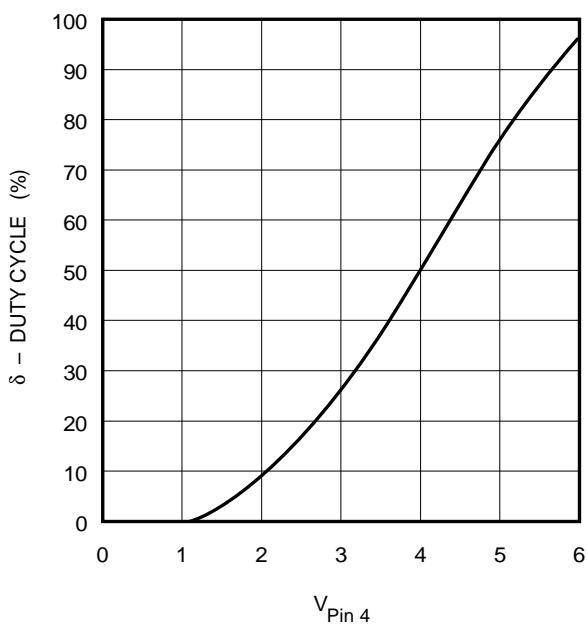

**Maximum Duty Cycle vs
Base Voltage on Q1**

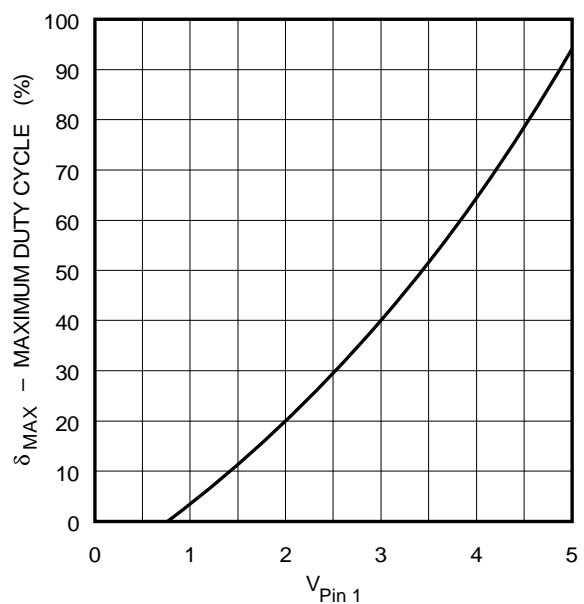

TYPICAL PERFORMANCE CHARACTERISTICS — ERROR AMPLIFIER

Power Derating Curve

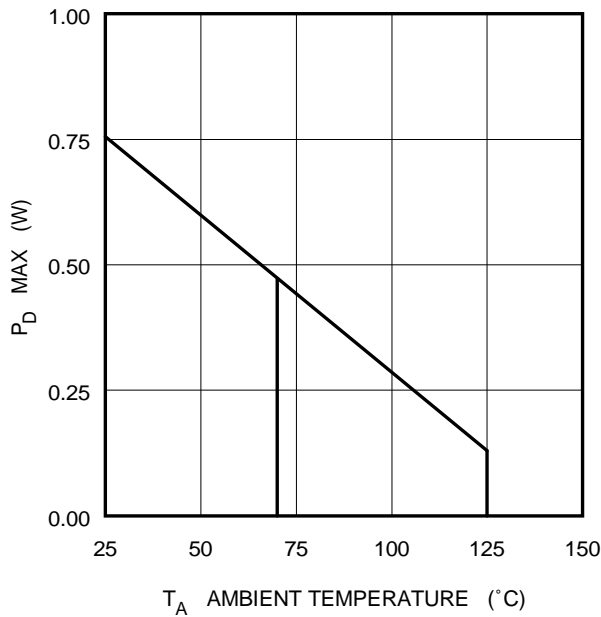

$$P_D = V_{CC} I_{CC} + (V_{CC} - V_Z) I_Z + (V_{pin7} I_{pin7} \times \delta)$$

Slow Start Voltage

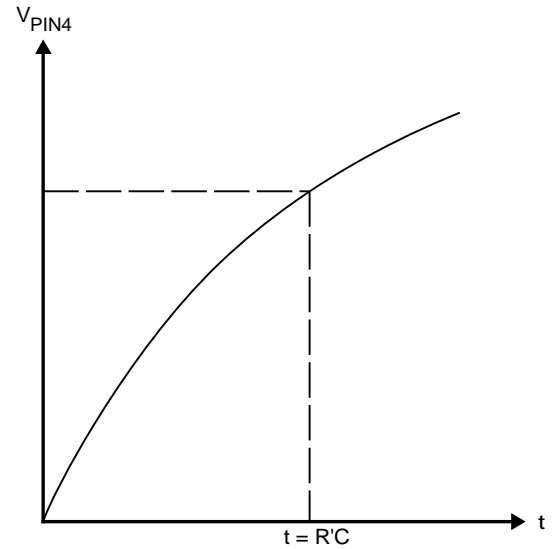

Typical Frequency Plot vs R_T and C_T

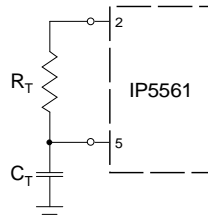
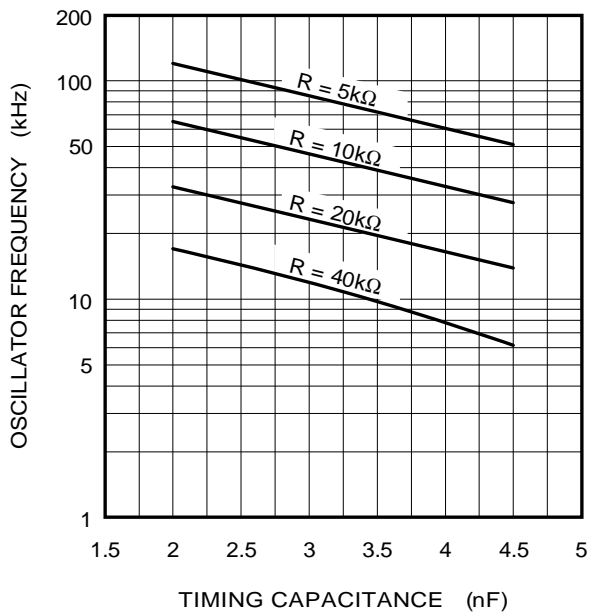

Start-up Circuit (Optional)

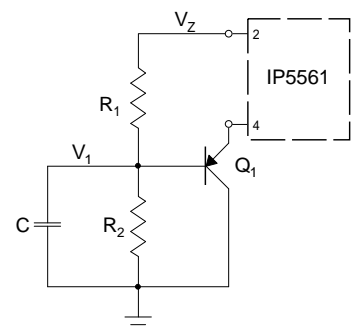

$$\delta_{max} = f \left(\frac{R_2}{R_1 + R_2} V_Z + V_{BE Q1} \right)$$