

Universal Input Linear Fluorescent Ballast using the IR2167

Cecilia Contenti, Dana Wilhelm and Tom Ribarich

Features

- Drives 1 x 35W TL5 Lamp (or 1X28WTL5 Lamp)
- Input Voltage: 80-260Vac
- High Power Factor/Low THD
- High Frequency Operation (42kHz)
- Lamp Filament Preheating
- Lamp Fault Protection with Auto-Restart
- Brownout Protection
- End of Lamp Life Shutdown
- IR2167 HVIC Ballast Controller

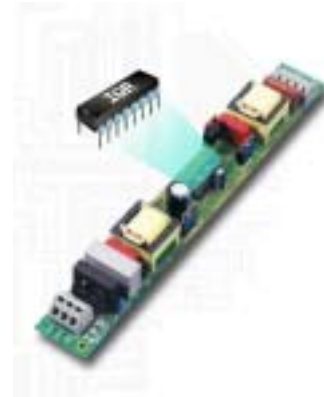

Description

The IR2167 Demo Board is a high efficiency, high power factor, fixed output electronic ballast designed for driving rapid start fluorescent lamp types. The design contains an EMI filter, active power factor correction and a ballast control circuit using the IR2167. This demo board is intended to ease the evaluation of the IR2167 Ballast Control IC, demonstrate PCB layout techniques and serve as an aid in the development of production ballast's using the International Rectifier IR2167.

Ballast Block Diagram

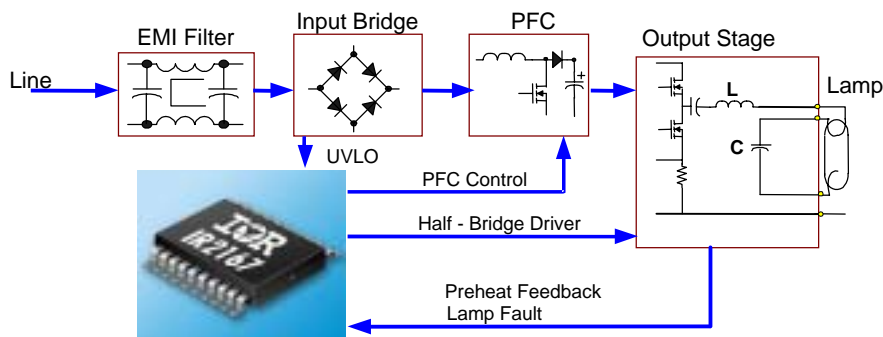

Parameter	Units	Value
Lamp Type		35W TL5
Input Power	[W]	35
Lamp running voltage	[Vpp]	750
Run Mode Frequency	[kHz]	42
Preheat Mode Frequency	[kHz]	56
Preheat Time	[s]	1
Lamp Preheat Voltage	[Vpp]	400Vpp
Ignition Ramp Mode Frequency	[kHz]	36
Ignition Voltage	[Vpp]	2000
Input AC Voltage Range	[VACrms]	80-260VAC
Power Factor		0.99 at 120VAC
Total Harmonic Distortion	[%]	10 at 120VAC

Note: Measurements performed with input AC line voltage = 220Vrms

Fault Protection Characteristics

Fault	Ballast	Restart Operation
Line voltage low	Deactivates	Increase line voltage
Upper filament broken	Deactivates	Lamp exchange
Lower filament broken	Deactivates	Lamp exchange
Failure to ignite	Deactivates	Lamp exchange
Open circuit (no lamp)	Deactivates	Lamp exchange
End of life	Deactivates	Lamp exchange

Functional Description

Overview

The IR2167 Demo Board consists of an EMI filter, an active power factor correction section, a ballast control section and a resonant lamp output stage. The active power factor correction section is a boost converter operating in critical conduction mode, free-running frequency mode. The ballast control section provides frequency modulation control of a traditional RCL lamp resonant output circuit and is easily adaptable to a wide variety of lamp types. The ballast control section also provides the necessary circuitry to perform lamp fault detection, shutdown and auto-restart. All functional descriptions refer to the IR2167 Demo Board schematic diagram.

IR2167 Demo Board

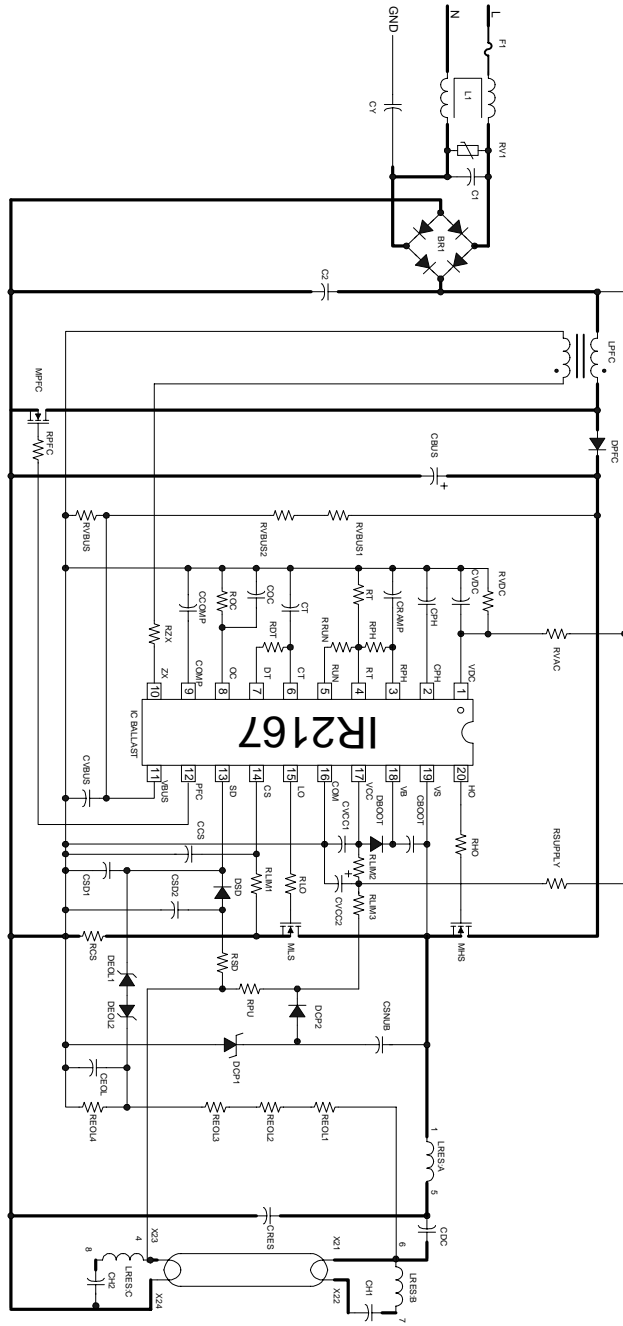

Note: Thick traces represent high-frequency, high-current paths. Lead lengths should be minimized to avoid high-frequency noise problems

2167 Single Lamp, Voltage mode heating
 JC1 and JC2 no mounted, JV1 and JV2 mounted

Bill Of Materials

Lamp type: TL5/35W, Line Input Voltage: 80-260 VAC

Note: Different lamp types require different frequency programming components.

Item #	Qt	Manufacturer	Part Number	Description	Reference
1	1	International Rectifier	DF10S	Bridge Rectifier, 1A 1000V	BR1
2	1	Roederstein	WY	Capacitor, 2.2nF 275 VAC Y Cap	CY
3	1	Dale	CW-1/2	Resistor, 0.50Ohm, 1/2W	F1
4	1	Roederstein	F1772433-2200	Capacitor, 0.33uF 275 VAC	C1
5	2	Wima	MKP10	Capacitor, 0.1uF 400 VDC	C2, CDC
6	1	Panasonic	ERZ-V05D471	Transient Suppressor	RV1
7	1		EEU-EB2W100	Capacitor, 10uF 450VDC 105C	CBUS
8	1	Panasonic	ELF-15N007A	EMI Inductor, 1X10mH 0.7Apk	L1
9	1	B.I. technologies	HM00-01762	PFC Inductor, 1.0mH 2.0Apk/ secondary 10 turns	LPFC
10	3	Panasonic	ECJ-2VB1HC104K	Capacitor, 0.1uF SMT 0805	CBOOT, CVCC1, COC
11	1	Panasonic	ECJ-2YB1C474K	Capacitor, 0.47uF SMT 0805	CSD1
12	3			Capacitor, 0.47uF SMT 1206	CVDC, CSD2, CEOL
13	1			Capacitor, 0.01uF SMT 0805	CVBUS
14	1	Panasonic	ECE-A1HGE02R2	Capacitor, 2.2uF 50VDC 105C	CVCC2
15	3	Panasonic		Capacitor, 0.68uF SMT 1206	CCOMP, CRAMP, CPH
16	1	Digi-key	311-1183-1-ND	Capacitor, 1nF 1KV SMT 1812	CSNUB
17	1	WIMA	FKP1	Capacitor, 3.3nF 2KV	CRES
18	1	Panasonic	ECU-V1H471KBN	Capacitor, 470pF SMT 0805	CT
19	2	Digi-key	MURS160DICT-ND	Diode, 1A 600V, SMT SMB	DBOOT, DPFC
20	3	Diodes	LL4148DICT-ND	Diode, 1N4148 SMT DL35	DCP2, DCP1, DSD
21	1	International Rectifier	IR2167	IC, Ballast Driver /PFC	IC BALLAST
22	1	B.I. technologies	HM00-01761	Inductor, 4.0mH 1.5Apk/ 10	LRES
23	3	International Rectifier	IRF830	Transistor, MOSFET	MPFC, MHS, MLS
24	3	Panasonic	ERJ-8GEYJ22	Resistor, 22 ohm SMT 1206	RPFC, RLO, RHO
25	1	Panasonic		Resistor, 110K ohm SMT 1206	RVDC
26	1	Panasonic		Resistor, 16Kohm 1% SMT 1206	RPH
27	1	Panasonic		Resistor, 43Kohm 1% SMT 1206	RRUN
28	1	Yageo	270KQBK-ND	Resistor, 270K ohm ¼ watt	RSUPPLY
29	3	Panasonic	ERJ-8GEYJ680K	Resistor, 680K ohm SMT 1206	RVBUS1, RVBUS2, RSD
30	2	Panasonic		Resistor, 20K ohm SMT 1206	RT, ROC
31	1	Panasonic		Resistor, 10K ohm SMT 1206	RDT
32	1			Resistor, 1 megohm SMT 1206	RPU
33	2	Panasonic		Resistor, 10 ohm SMT 1206	RLIM2, RLIM3
34	1	Panasonic	ERJ-8GEYJ1K	Resistor, 1K ohm SMT 1206	RLIM1
35	1	Panasonic		Resistor, 1.2 ohm SMT 2010	RCS
36	1			Resistor, 2.2 megohm 1/4W	RVAC
37	1			Resistor, 22K ohm SMT 1206	RZX
38	1	Digi-Key	ZMM5231BDICTND	5.1V Zener 0.5W SMT	DEOL2
39	1	Digi-Key	ZMM5236BDICTND	7.5V Zener 0.5W SMT	DEOL1
40	1			Resistor, 12.5Kohm 5% SMT 805	RVBUS
	4			Jumper	JV1, JV2, J1, J2

Item #	Qt	Manufacturer	Part Number	Description	Reference
41	2	RG Allen		Capacitor, 0.1uF, 50V	CH1, CH2
42	3			Resistor, 220K ohm SMT 1206	REOL1, 2, 3
43	1			Resistor, 160K ohm SMT 1206	REOL4
44	1	WAGO	235-203	Connector, 3 terminal	X1
45	1	WAGO	235-204	Connector, 4 terminal	X2
46	1			Capacitor, 100pF SMT 1206	CCS
				Not needed	RDC
Total		67 without Jumpers			

¹ A smaller number of turns: 6-8, could give better performance

Inductor Specs

International IRF Rectifier **INDUCTOR SPECIFICATION**
TYPE : LPFC

CORE SIZE GAP LENGTH mm
 BOBBIN PINS
 CORE MATERIAL
 NOMINAL INDUCTANCE mH
 MAXIMUM CURRENT Apk
 MAXIMUM CORE TEMPERATURE °C

WINDING	START PIN	FINISH PIN	TURNS	WIRE DIAMETER (mm)
MAIN	1	6	125	4 strands of AWG 32
ZX	3	8	10	4 strands of AWG 32

ELECTRICAL LAYOUT

PHYSICAL LAYOUT

TEST (TEST FREQUENCY = 50kHz)

MAIN WINDING INDUCTANCE mH mH
 MAIN WINDING RESISTANCE Ohms

NOTE : Inductor must not saturate at maximum current and maximum core temperature at given test frequency.

International IGR Rectifier **INDUCTOR SPECIFICATION**
TYPE : LRES(VOLTAGE MODE)

CORE SIZE GAP LENGTH mm
BOBBIN PINS
CORE MATERIAL
NOMINAL INDUCTANCE mH
MAXIMUM CURRENT Apk
MAXIMUM CORE TEMPERATURE °C

WINDING	START PIN	FINISH PIN	TURNS	WIRE DIAMETER (mm)
MAIN	1	8	250	4 strands of AWG 32
CATHODE (1)	6	7	10	4 strands of AWG 32
CATHODE (2)	4	5	10	4 strands of AWG 32

ELECTRICAL LAYOUT **PHYSICAL LAYOUT** **TOP VIEW**

TEST (TEST FREQUENCY = 50kHz)
MAIN WINDING INDUCTANCE mH mH
MAIN WINDING RESISTANCE Ohms

NOTE : Inductor must not saturate at maximum current and maximum core temperature at given test frequency.

Demo board Overview

This demo-board is designed for single TL5/35W Lamp, voltage mode heating (JV1, JV2 mounted). TL5 lamps are becoming more popular due to their lower profile and higher lumen/ watt output. These lamps, however, can be more difficult to control due to their higher ignition and running voltages. A typical ballast output stage using current-mode filament heating (filament placed inside L-C tank) will result in excessive filament current during running. The output stage has therefore been configured for voltage-mode filament heating using secondary windings off of the resonant inductor LRES. The lamp has been placed outside the under-damped resonant circuit loop, which consist of LRES and CRES. The filament heating during preheat can be adjusted with the capacitors CH1 and CH2. The result is a more flexible ballast output stage necessary for fulfilling the lamp requirements. The DC blocking capacitor, CDC, is also placed outside the under-damped resonant circuit loop such that it does not influence the natural resonance frequency of LRES and CRES. The snubber capacitor, CSNUBB, serves as charge pump for supplying the IR2167.

The IR2167 Ballast Control IC is used to program the ballast operating points and protect the ballast against conditions such as lamp strike failures, low DC bus, thermal overload or lamp failure during normal operations. It is also used to regulate the DC bus and for power factor control allowing high power factor and low harmonic distortion.

Power Factor Correction Section

The power factor correction section contained in the IR2167 forms the control for a boost topology circuit operating in critical conduction mode. This topology is designed to step-up and regulate the output DC bus voltage while drawing sinusoidal current from the line (low THD) which is “in phase” with the AC input line voltage (HPF).

Ballast Control Section

The ballast control section of the IR2167 Ballast Control IC contains an oscillator, a high voltage half-bridge gate driver and lamp fault protection circuitry. Please, refer to the datasheet of this IC for the block diagram and the state diagram. Following is a breakdown of the operation of the ballast in all of the different modes of operation. Please, refer to the AN: IRPLLNR2 for the ballast section design (www.irf.com/Lighting).

Startup Mode

When power is initially applied to the ballast, the voltage on the VCC pin of the IR2167 begins to charge up. The voltage for the IR2167 is derived from the current supplied from the rectified AC line through startup resistor RSUPPLY. During this initial startup when the VCC voltage of the IR2167 is below its rising under-voltage lock-out threshold (11.4V), it is in its UVLO and also its micro-power mode. The micro-power mode of the IR2167 allows the use of a large value, low wattage startup resistor (RSUPPLY). When the voltage on the IR2167 reaches the rising under-voltage lockout threshold, the oscillator is enabled (this assumes that there are no fault conditions) and drives the half-bridge output MOSFETs (MHS and MLS). When the half-bridge is oscillating, capacitor CSNUB, diodes DCP1 and DCP2 form a snubber /charge pump circuit which limits the rise and fall time at the half-bridge output and also supplies the current to charge capacitor CVCC2 to the VCC clamp voltage (approx. 15.6V) of IR2167. When the rising under-voltage lockout threshold of the IR2167 is reached, the PFC oscillator starts to oscillate and drive MOSFET MPFC to boost and regulate the bus voltage to 400 VDC. Oscillagaph of the start up of the VCC of the IR2167 DC is shown in figure 1.

I

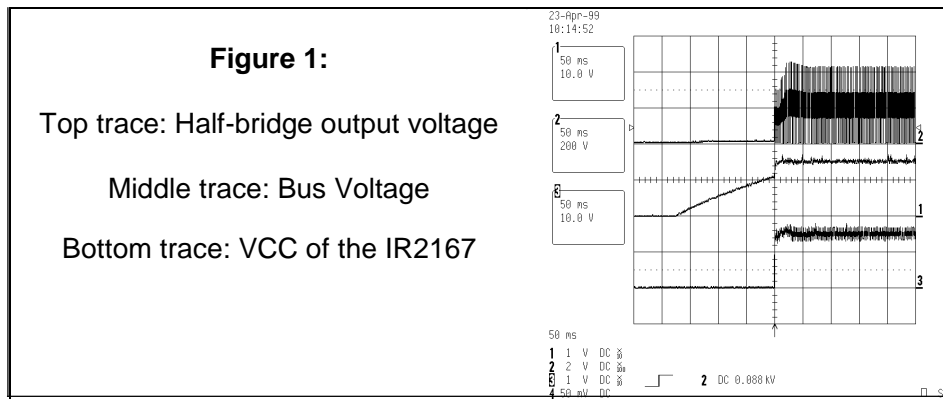

Preheat Mode

When the ballast reaches the end of the UVLO mode, the Preheat mode is entered. At this point the ballast control oscillator of the IR2167 has begun to operate and the half-bridge output is driving the resonant load (lamp) circuit. The ballast control section oscillator of the IR2167 is similar to oscillators found in many popular PWM voltage regulator ICs and consists of a timing capacitor and resistor connected to ground. Resistors RT and RPH program a current which determines the ramp up time of capacitor CT and resistor RDT determines the ramp down time. The downward ramping time of CT is the dead time between the switching off of the LO (HO) and the switching on of the HO (LO) pins on the IR2167. The Preheat mode frequency of oscillation is selected such that the voltage appearing across the lamp is below the minimum lamp ignition voltage while supplying enough current to preheat the lamp filaments to the correct emission temperature within the Preheat mode period. The preheating of the lamp filaments is performed with a constant voltage during the Preheat mode. The waveform in Figure 2 shows the lamp filament current while Figure 3 shows lamp filament voltage during the normal Startup, Preheat and Ignition Ramp modes of the ballast.

Figure 2:
 Lamp filament current during
 Preheat and Ignition Ramp
 (500mA / div)
 (Crossed lamps)

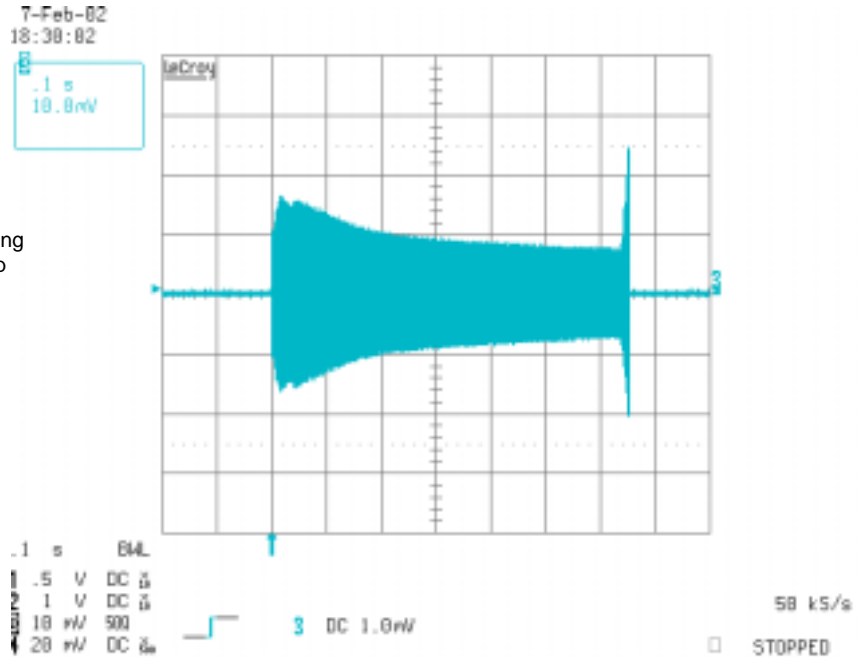

Figure 3:
 Lamp filament voltage
 during preheat and
 Ignition Ramp
 (Crossed lamps)

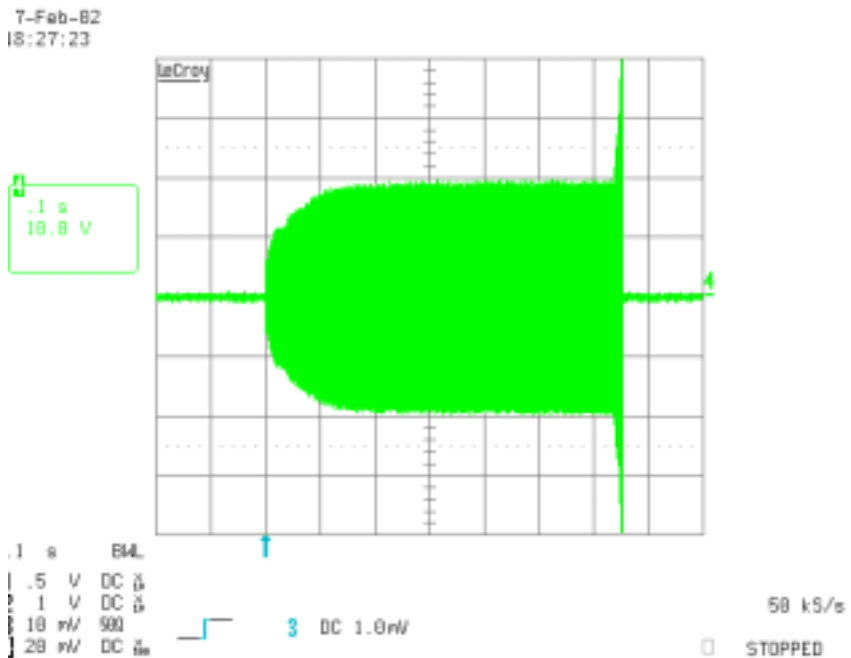

Figure 4 shows a plot of the half-bridge oscillation frequency as a function of time for all of the normal modes of operation: Preheat mode, Ignition Ramp mode and Run mode. As shown in Figure 4 there is an initial startup frequency that is much higher than the steady state Preheat mode frequency that lasts for only a short duration. This is done to ensure that the initial voltage appearing across the lamp at the startup of oscillation does not exceed the minimum lamp ignition voltage. If, at the initiation of oscillation of the half-bridge, the voltage across the lamp is large enough, a visible flash of the lamp occurs which should be avoided. This in effect is a cold strike of the lamp, which could shorten the life of the lamp. Figure 5 shows the lamp voltage without the high initial startup frequency while Figure 6 shows the lamp voltage with the high initial frequency startup.

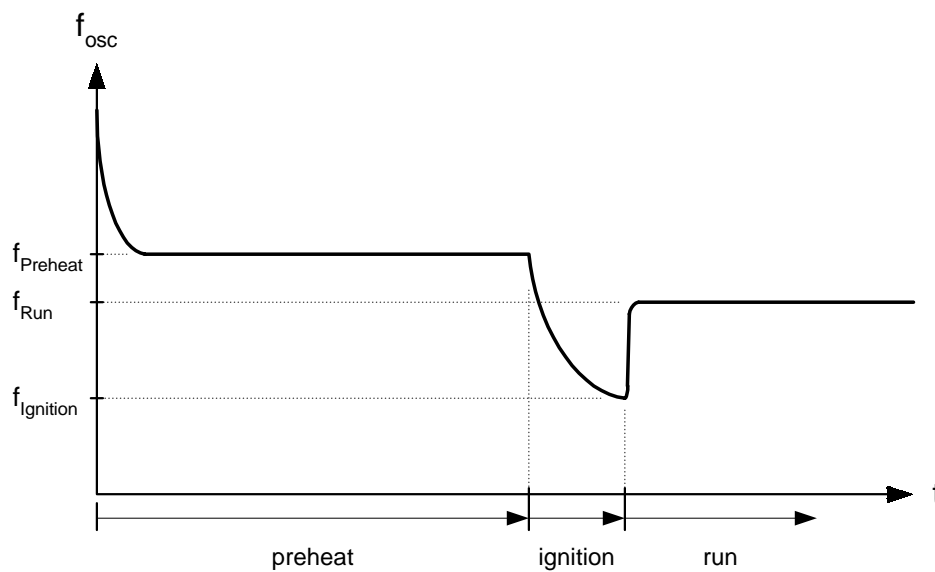
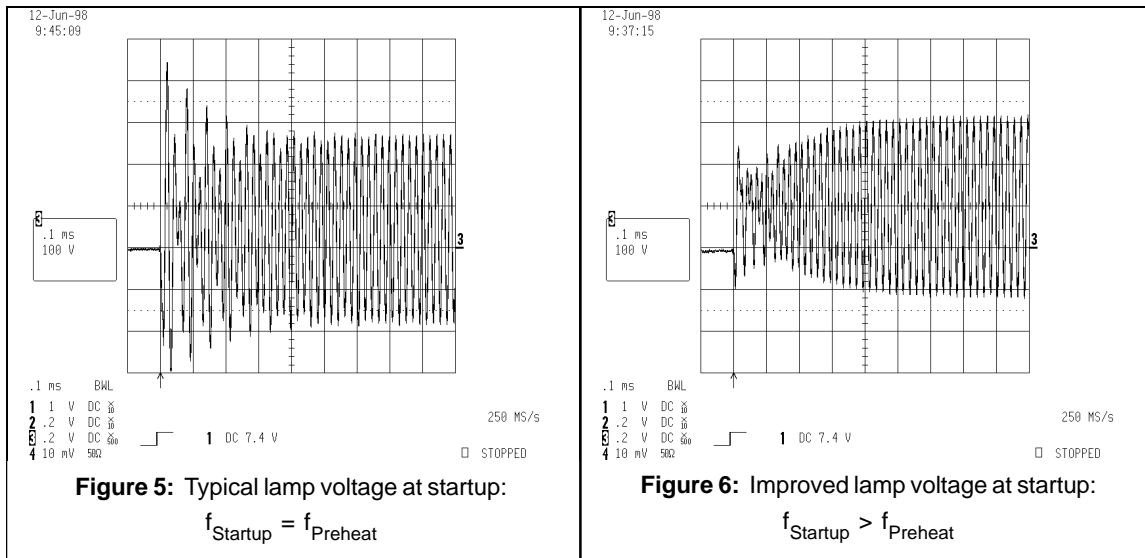

Figure 4: Oscillator frequency versus time, Normal operating conditions



The duration of the Preheat mode as well as the mode of operation of the ballast are determined by the voltage on the CPH pin of the IR2167. At the completion of the UVLO mode, Preheat mode is entered and an internal current source is activated at the CPH pin of the IR2167, which begins to charge up capacitor CPH. The ballast remains in the Preheat mode until the voltage on the CPH pin exceeds the Ignition Ramp mode threshold (4V).

Ignition Ramp Mode

At the completion of the Preheat mode ($4V < \text{CPH pin} < 5.1V$) the ballast switches to the Ignition Ramp mode and the frequency ramps down to the ignition frequency. The frequency ramping is accomplished by turning off the internal open drain MOSFET on the RPH pin of the IR2167 (see IR2167 block diagram). Resistor RPH is no longer connected directly in parallel with resistor RT. The shift in frequency does not occur in a step function but rather with an exponential decay because of capacitor CRAMP in series with resistor RPH to COM. The duration of this frequency ramp is determined by the time constant of the RC combination of capacitor CRAMP and resistor RPH. The minimum frequency of oscillation occurs at the end of this ramp and is determined by resistor RT and capacitor CT. During this ramping downward of the frequency, the voltage across the lamp increases in magnitude as the frequency approaches the resonant frequency of the LC load circuit until the lamp ignition voltage is exceeded and the lamp ignites. Figure 7 shows the ramping of voltage appearing across the lamp. Note that the sudden drop in lamp voltage indicates that the lamp has ignited.

Also note that the voltage on capacitor CRAMP is still increasing at the point when the lamp has already ignited meaning the frequency is still ramping down to the final minimum ignition frequency. This minimum frequency corresponds to the absolute maximum ignition voltage required by the lamp under all conditions. Figure 8 shows the ignition ramp and the maximum ignition voltage with crossed lamp (in this case the oscillator ramps down to the final minimum ignition frequency).

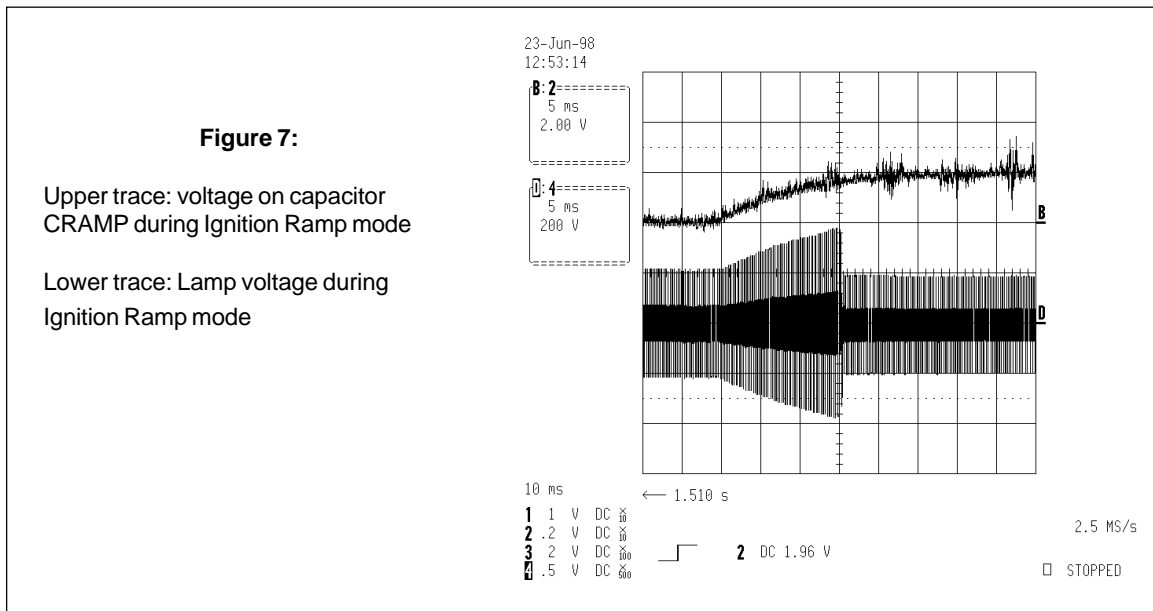

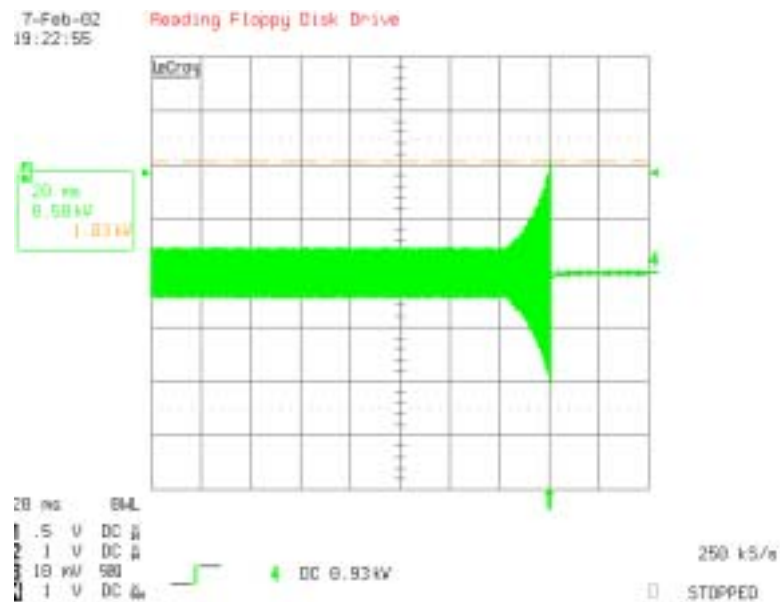
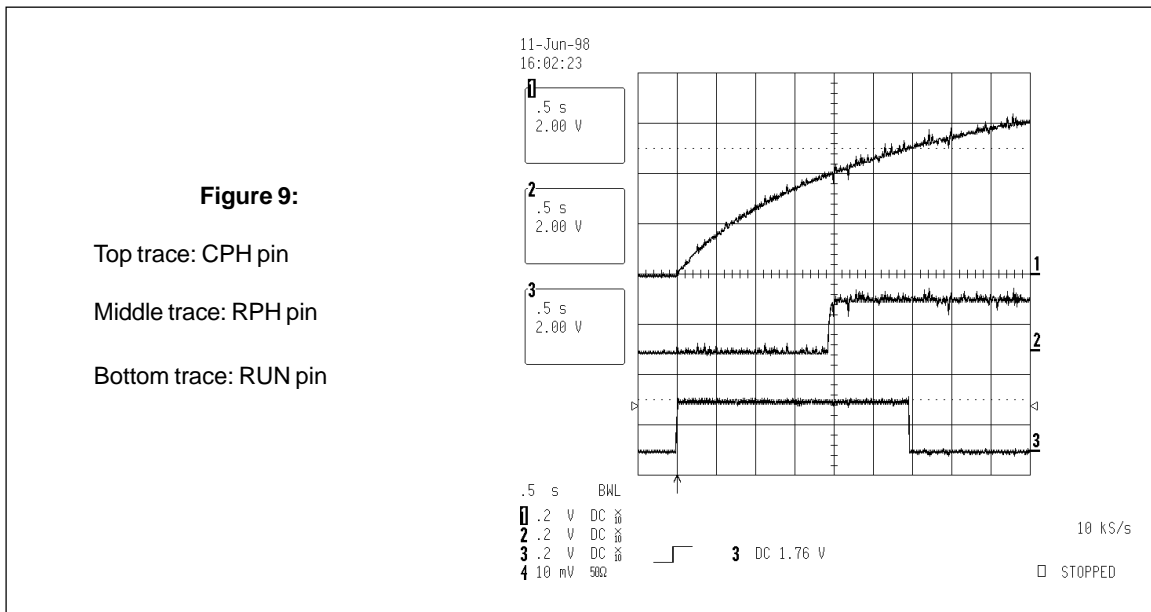

Figure 8: Ignition ramp (crossed lamps)

During the Ignition Ramp mode the voltage on the CPH pin of the IR2167 continues to ramp up until the voltage at the CPH pin of the IR2167 exceeds the Run mode threshold (5.1V). Over-current sensing is also enabled at the beginning of the Ignition Ramp mode. A full explanation of the functionality of the over-current sensing is in the section on Fault Mode.

Run Mode

At the end of the Ignition Ramp mode (CPH pin > 5.1V) the ballast switches to the Run mode at which point the frequency is shifted to the run frequency. The run frequency is determined by the parallel combination of resistors RT and RRUN and capacitor CT. Resistor RRUN is connected in parallel by turning on the internal open drain MOSFET connected to the RUN pin of the IR2167 (see IR2167 block diagram). The sensing of under-current conditions and the 1-3V window comparator in the SD pin are also enabled at the beginning of the Run mode. The full explanation of the functionality of the under-current sensing and end-of-life sensing is in the section on Fault Mode. Figure 9 shows the functionality of the CPH, RPH and RUN pins of the IR2167 during Startup, Preheat, Ignition Ramp and Run modes.



The Run mode frequency is that at which the lamp is driven to the lamp manufacturer’s recommended lamp power rating. The running frequency of the lamp resonant output stage for selected component values is defined as,

$$f_{run} = \frac{1}{2\pi} \sqrt{\frac{1}{LC} - 2\left(\frac{P_{Lamp}}{CV^2_{Lamp}}\right)^2} + \sqrt{\left[\frac{1}{LC} - 2\left(\frac{P_{Lamp}}{CV^2_{Lamp}}\right)^2\right]^2 - 4\frac{1 - \left(\frac{2V_{DCbus}}{V_{Lamp}\pi}\right)^2}{L^2 C^2}}$$

- L = Lamp resonant circuit inductor (L3) (H)
- C = Lamp resonant circuit capacitor (C14) (F)
- P_{Lamp} = Lamp running power (W)
- V_{Lamp} = Lamp running voltage amplitude (V)

Figure 10 shows the voltage appearing across the lamp during Startup, Preheat, Ignition Ramp and Run modes.

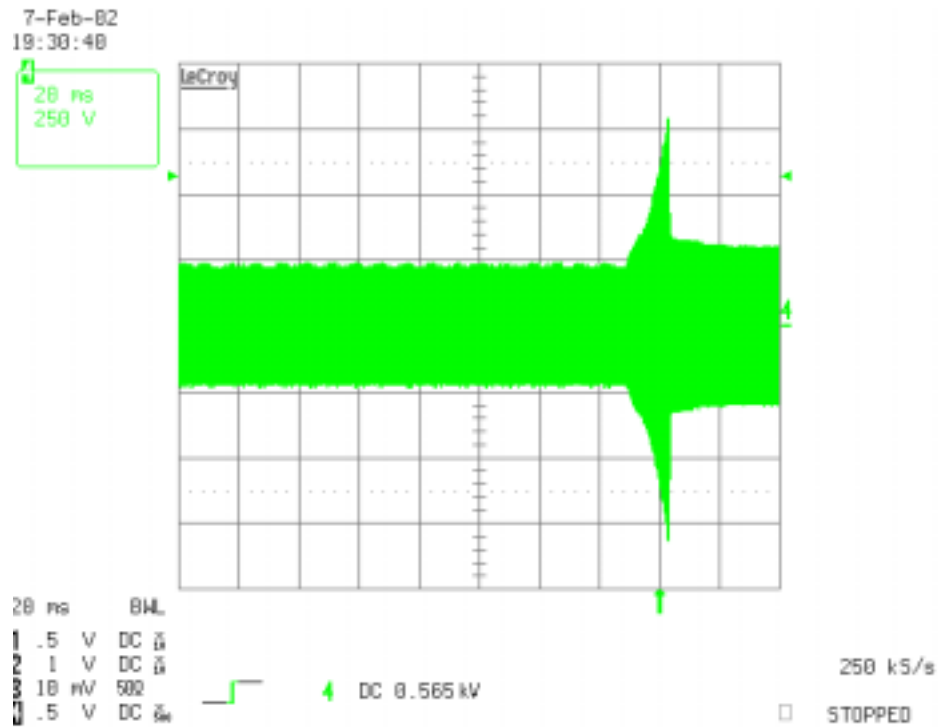

Fig. 10: Preheat, Ignition Ramp and Run Voltage in the lamp

Normal Power down

A normal power down occurs when the AC line voltage is disconnected from the ballast. When this occurs the voltage on the VDC pin of the IR2167 drops below the line fault threshold (3V) and the IR2167 shuts down in a controlled fashion. The ballast control oscillator is stopped, the half-bridge driver outputs (LO and HO) are turned off and capacitors CPH, CRAMP, CSTART and CT are discharged. IR2167 also goes into its UVLO/micro-power mode and the bus voltage begins to collapse.

Resistors RVAC, RVDC and capacitor CVDC form a voltage divider/filter network, which is connected to the VDC pin of the IR2167 and is used to determine if the line voltage falls below permissible levels. This happens when the line voltage is cycled or possibly a brownout condition occurs. The VDC pin of the IR2167 senses a fault if the voltage at the pin falls below 3 volts and shutdown of the ballast occurs. The ballast remains shutdown until the voltage at the VDC pin rises above 5.1 volts. At this time if there are no other fault conditions the ballast will go through a full Preheat, Ignition Ramp and Run mode. As in the case of the SD pin of the IR2167, the VDC pin of the IR2167 is active during all modes of operation of the ballast.

Lamp removal and autorestart

Resistors RPU, RSD and capacitor CSD1 form a divider/filter network which is used to detect an open lower lamp filament and/or lamp replacement. Under normal conditions, the voltage across CSD2 is close to zero. However, if the lower filament becomes open or the lamp is removed, the voltage across CSD2 increases above the 5.1V threshold for the SD pin of the IR2167 and signals a lamp removal condition, which in turn puts the ballast into UVLO mode. The ballast remains in the UVLO mode until the lamp replacement is performed. If the lamp is replaced with a lamp with a good lower filament, the voltage on the SD pin of the IR2167 drops back below the threshold and the ballast will go through a restart. Line voltage cycling is also used to restart the ballast for all lamp fault conditions. The ballast will go through a full Preheat, Ignition Ramp and Run modes any time a restart is performed. Note that the SD pin of the IR2167 is active during all modes of operation.

Fault Mode

Fault mode is when the ballast driver is shutdown due to the detection of a lamp fault. Note that when the ballast is in this Fault mode the power factor correction section of the ballast is also shutdown and the bus voltage will drop to the non-boosted/unregulated level. There are several lamp fault conditions that can put the ballast into the Fault mode. The lamp fault conditions detected include: near/below resonance (under-current) detection, hard-switching detection, over-current detection (CS pin) and end of life or no load detection (SD pin). Resistor RCS in the source lead of the low side MOSFET (MHS) serves as the current sensing point for the half-bridge, which is used to detect these lamp fault conditions. In operation when the half-bridge is oscillating, a voltage appears across RCS whenever the low side MOSFET, MHS, is turned on or the high side MOSFET, MLS, is turned off. The magnitude of this voltage directly relates to the current in the lamp resonant circuit. Figure 11 shows the voltage which appears across resistor RCS during normal Run mode conditions. Also shown in Figure 11 are the gate drive signals for the low side MOSFET (LO pin) and the high side MOSFET (HO-VS pin).

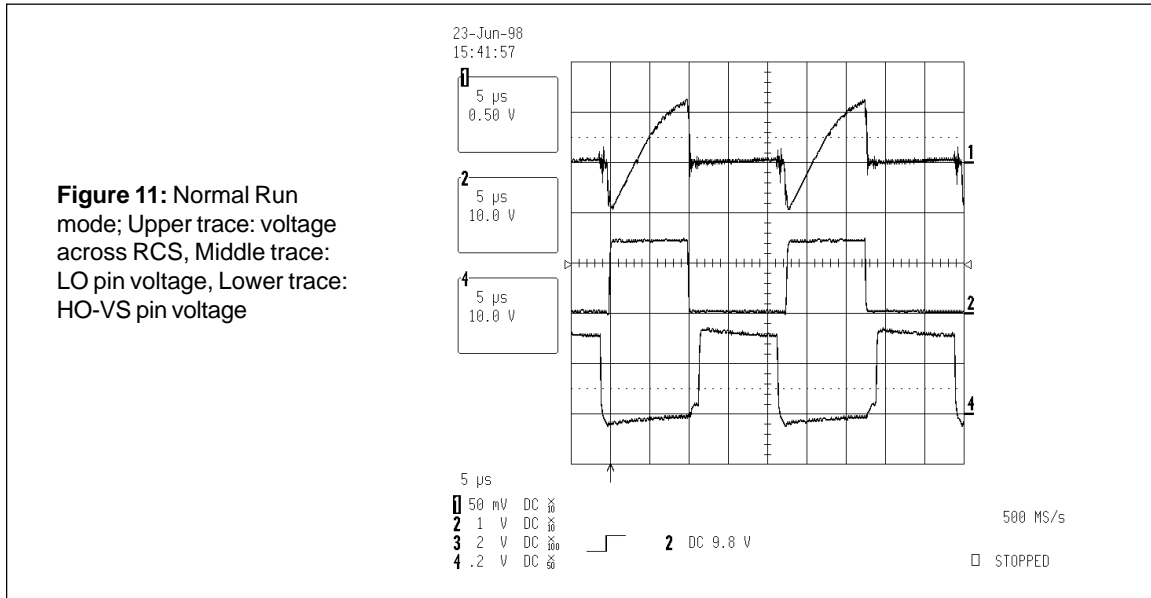

During the Preheat mode the voltage across resistor RCS is not measured. However, at the end of Preheat mode (the beginning of the Ignition Ramp mode) the hard-switching and over-current detection are enabled. If at any time thereafter the voltage magnitude across resistor RCS rises above the over-current (CS+) threshold of the CS pin of the IR2167, a lamp fault condition is signaled and the half-bridge output MOSFETs', (MHS and MLS) are turned off and the ballast goes into Fault mode. This can happen if the lamp fails to ignite or if the upper cathode is open circuit (or upper filament open in current mode configuration). For failure to ignite the lamp, the current in the half-bridge increases and thus the voltage across resistor RCS increases above the over-current threshold signaling a fault. Figure 12 shows the voltage across resistor RCS and the voltage appearing across the lamp when the ballast detects a failure to ignite the lamp and goes into Fault mode. The CS+ threshold is determined by resistor ROC. An internal current source of 50uA is connected to the OC pin of the IR2167 which when applied to resistor ROC sets a voltage at the OC pin. This voltage is the CS+ threshold of the IR2167. Figure 13 shows the voltage appearing across the lamp during the tail end of the Preheat mode and the Ignition Ramp mode for a failure of the lamp to ignite condition. If the upper cathode is open circuit (or upper filament open in current mode configuration), the half-bridge output hard-switches and each time the low side MOSFET (MHS) is turned on a large current pulse occurs and thus a large voltage pulse occurs across resistor RCS signaling a fault, Figure 14 shows this hard-switching condition. Figure 15 shows the lamp voltage during the Preheat mode and

beginning of Ignition Ramp mode for this hard-switching condition when the lamp fault condition is detected. The ballast will remain in Fault mode until either the line voltage is cycled or a lamp replacement is performed.

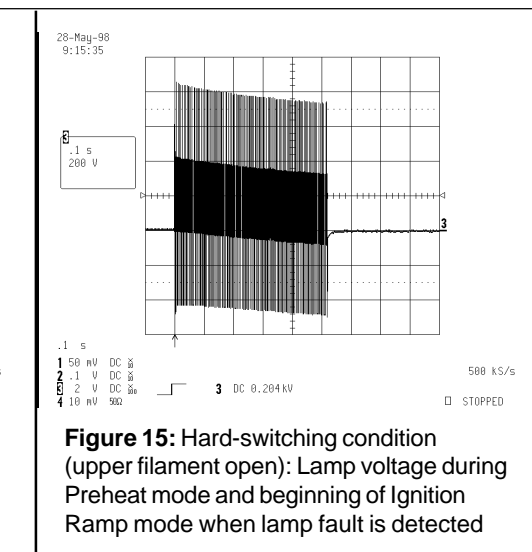
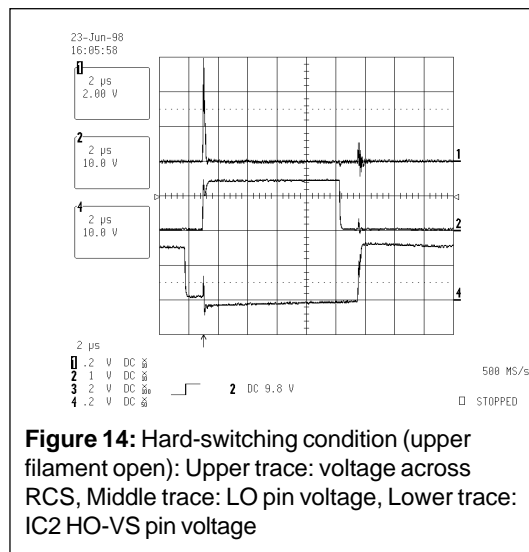
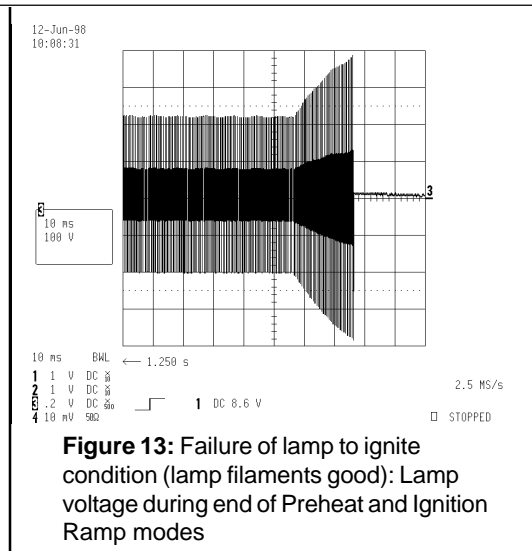
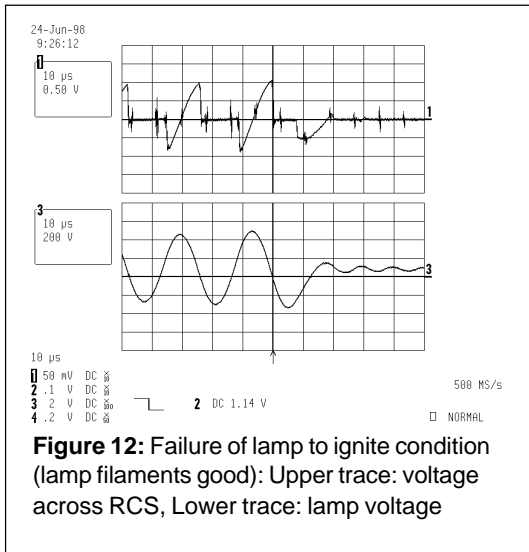

At the completion of the Ignition Ramp mode (beginning of the Run mode) the near/below resonance (under-current) detection is also enabled. Near/below resonance detection is performed by synchronously sensing the voltage across resistor RCS, which relates to the current flowing in the low side MOSFET (MLS), just prior to the turn off of MHS. If this voltage is lower than the near/below resonance threshold (CS- = 0.2V) of the CS pin of the IR2167, a lamp fault condition is signaled and the ballast goes into Fault mode. This could occur if the frequency of oscillation becomes too close to the resonant frequency of the load circuit and the current in the load circuit commutates to close to zero. Figure 16 shows a near/below resonance condition where the voltage on resistor RCS falls below the 0.2V threshold on the CS pin of the IR2167.

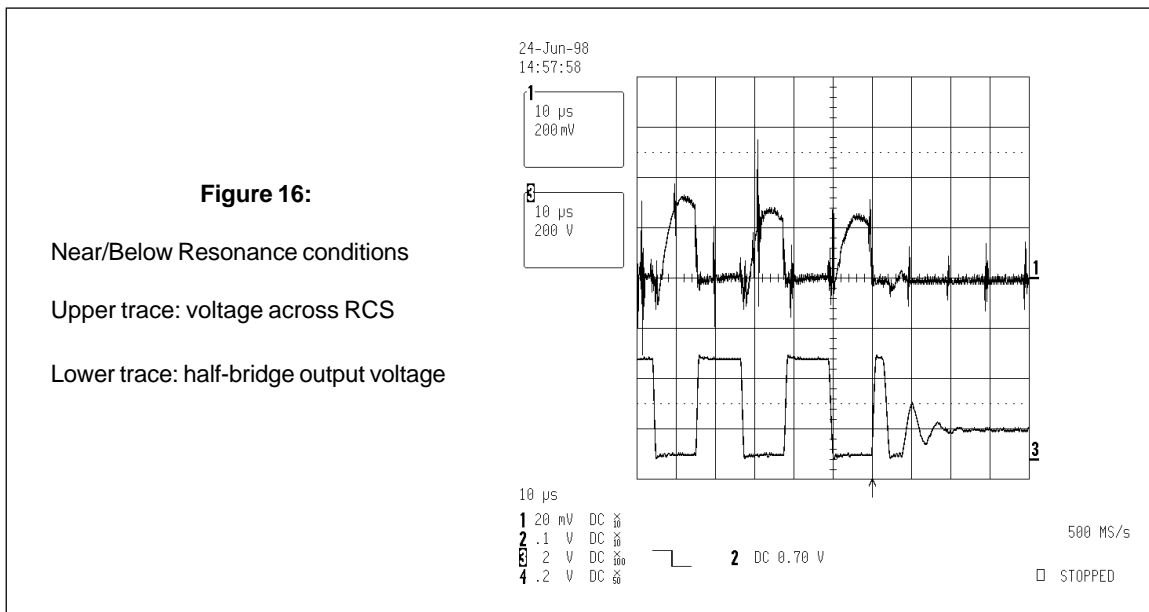

The components REOL1 REOL2, REOL3, REOL4, CEOL, DEOL1 and DEOL2 are used for end of life protection. The end-of-life window comparator is enabled at the beginning of the Run mode. If the voltage on the lamp change +20%, one of the zener diodes DEOL1 or DEOL2 will conduct and the voltage on pin SD of the IR2167 will fall outside the range of the internal window comparator 1-3V causing the IR2167 to go into Fault mode.

Improved End of Life solution

The same PCB can be used with a different end of life configuration. It is needed to put a capacitor in the place of DEOL1 diode (100nF), to short DEOL2 (0 Ohm resistor) and to reduce the capacitor in the SD pin CSD1 (100pF). The resultant circuit is shown in fig. 17.

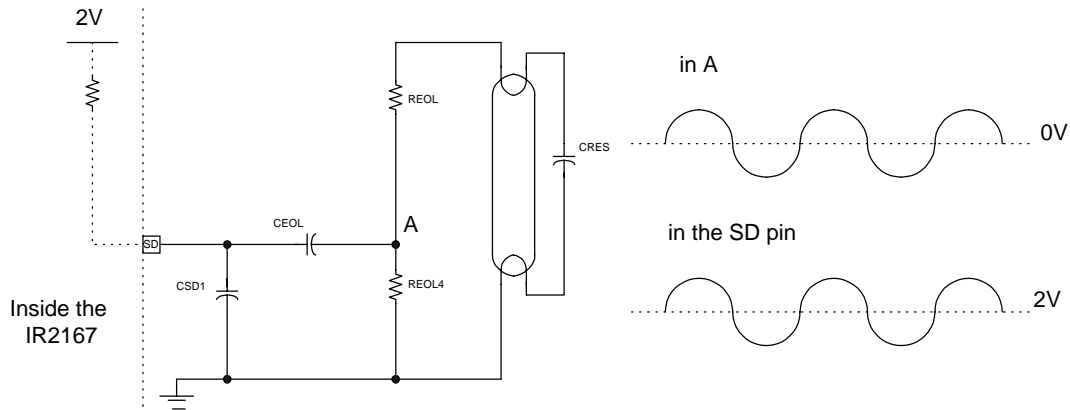

Fig. 17: Improved End-of-life circuit

The value of REOL4 is changed so that the lamp voltage during normal running produces a signal with 1.5 Vppk at the point (A) were the capacitor CEOL connects it to the SD pin. For a T5/35W lamp 1.2Kohm at REOL4 provides the correct voltage.

The SD pin is internally biased at 2V with 1Mohm impedance and therefore at the SD pin a signal varying between 1.25V and 2.75V will normally be present due to the AC coupling of the 100nF capacitor (CEOL).

During end of life the lamp voltage may increase either symmetrically (AC end of life, due to a similar deterioration in both cathode) or asymmetrically (DC end of life, due to a deterioration only in one cathode). This circuit is simpler and cheaper than the previous version and it has the advantage of detecting both failure modes.

The peak to peak voltage at the SD pin will increase (with 2V DC offset) in either case until the positive peak exceeds 3V and/or the negative peak drops below 1V, therefore triggering the window comparator shutdown. The threshold of end of life can be adjusted by changing the value of REOL4 (usually 30% Vlamp is required).

Figure 18 shows the voltage in the SD pin and the voltage on the lamp in these 4 cases: no end of life, DC end of life (upper cathode deteriorated and lower cathode deteriorated) and AC end of life (both filaments deteriorated in the same way).

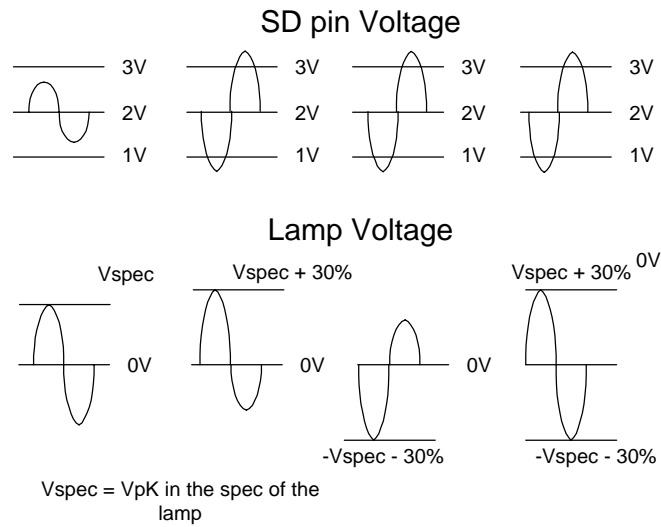
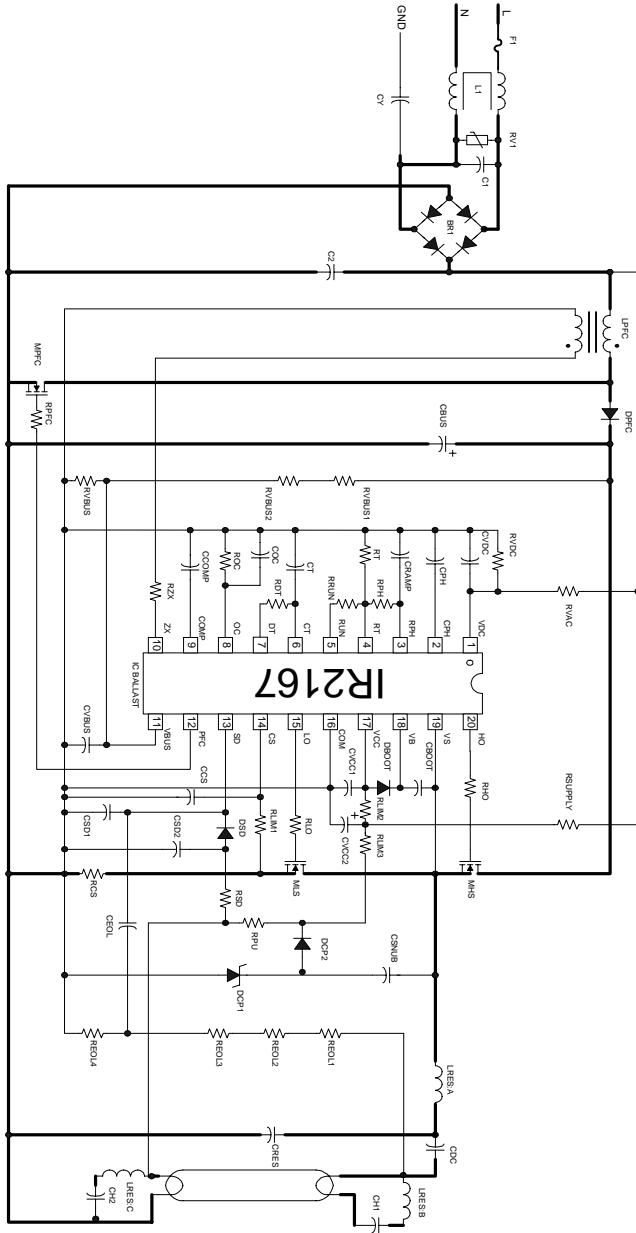

Figure 18: Voltage in the SD pin and voltage on the lamp in these 4 cases: no end of life, DC end of life and AC end of life.

2167 Single Lamp, Voltage mode heating improved End of Life Circuit
 JC1 and JC2 not mounted, JV1 and JV2 mounted



Note: Thick traces represent high-frequency, high-current paths. Lead lengths should be minimized to avoid high-frequency noise problems

Voltage mode Configuration Protection

Open cathode (one cathode disconnected completely) conditions are detected using the CS pin. Open filament condition is detected in the lower cathode using the pin SD. In the case of open filament in the upper cathode, the lamp preheats and ignites without causing over-current in the CS pin, this is usually not a problem. However, we propose a circuit that has shutdown for open filament as well using the SD pin (schematics of the whole circuit in the following page).

When the upper filament is connected, the transistor base is supplied with current via the 220K resistor from the DC bus. This keeps it switched on at all times while the upper filament provides a DC path. When the transistor is on the diode anode is held close to 0V so the SD pin is not affected by this circuit and stays at 2V.

When the upper filament is open circuit, the transistor loses its base current and switches off so the diode conducts and pulls the SD pin above the 5V threshold causing the system to shutdown. When the lamp fails in this way and is replaced, the transistor will switch on and so the ballast will restart without resetting the AC line.

Current mode configuration

The same PCB can be configured for current mode heating. It is needed to remove the Jumpers JV1 and JV2 and to introduce the Jumpers JC1 and JC2. It could be also useful to add a resistor RDC in parallel to CDC because in this configuration After initial start-up you could have some striations (visible dark rings) on the lamps for a short period (a few minutes) particularly when the lamp has been off for some time and is cold. The value should be in the order of 100kOhm 0.5W.

We suggest the use of the Ballast Designer software to determine the values of the components to use in this configuration.

2167 Single Lamp, Voltage mode heating plus open upper filaments protection:JC1 and JC2 not mounted, JV1 and JV2 mounted

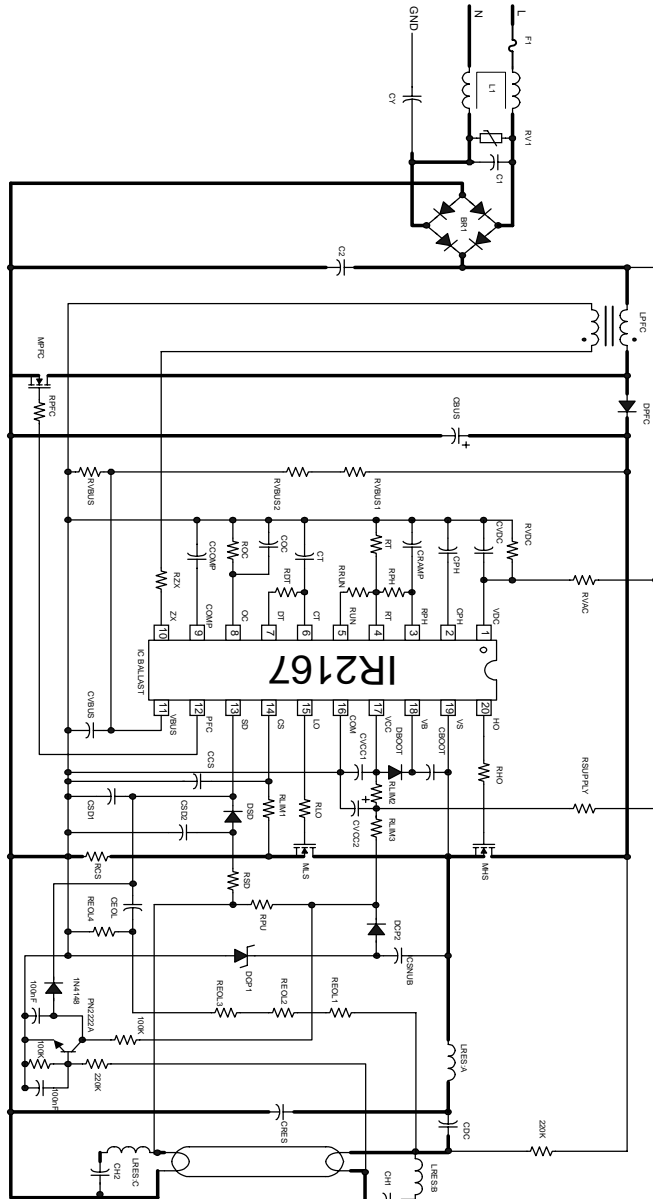

Note: Thick traces represent high-frequency, high-current paths. Lead lengths should be minimized to avoid high-frequency noise problems

RPLLNR3

2167 Single Lamp, Current mode heating JV1 and JV2 not mounted, JC1 and JC2 mounted

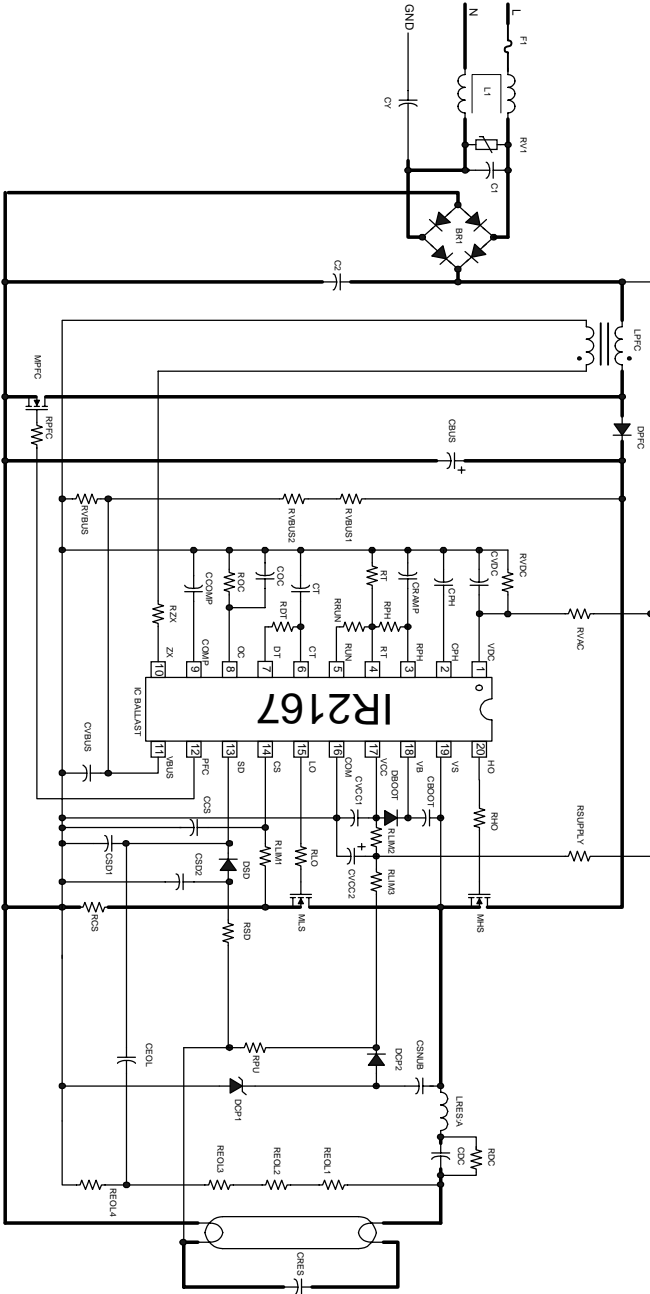

Note: Thick traces represent high-frequency, high-current paths. Lead lengths should be minimized to avoid high-frequency noise problems

Design Procedure to adapt the design to different lamp types

To adapt the design to different types of lamps you need to adjust the values of: LPFC, MPFC, MLO, MHO, CPH, RT, RPH, RRUN, RCS, ROC, CT, RDT, CRAMP, REOL4, CRES and LRES. Do not change any others values!

- 1) Use the Ballast Designer Software to set the values of LRES, CRES, MPFC, MLO and MHO, RDT, CT, CRAMP, CS and to set the starting values of LPFC, CPH, RT, RPH, RRUN and ROC.

Cross both lamps (i.e. connect a filament or resistor to each lamp cathode position but not a good lamp) and measure the lamp voltage at ignition using a storage oscilloscope.

- 1) Set ROC to get the right ignition voltage (decrease ROC to decrease the ignition voltage or decrease RCS to increase the ignition voltage)
- 2) Set RT to set the minimum frequency of the oscillator (increase RT to decrease the minimum frequency). Increase RT up to when the over-current protection is working in the worst case (i.e. the ballast shuts down at ignition):
- 3) Select CPH to set the preheat time (increase CPH to increase the preheat time)
- 4) Set RPH to set the right preheat current (increase RPH to increase the preheat current)
In case of voltage mode heating, increase CH1 and CH2 to increase the preheat voltage (use 6-7 turns in the secondary of LRES).

Connect both lamps correctly and measure the input power

- 5) Select RRUN to set the correct power, RRUN is required only if the run frequency is above the ignition frequency (increase RRUN to increase the power on the lamp)
- 6) Verify the value of LPFC at each limit of the line/load range:

Minimum load and maximum input voltage:

If the COMP pin becomes less than 400mV the PF will not operate in a stable manner and it is necessary to increase LPFC.

Maximum load and minimum input voltage:

If the PF does not operate in a stable manner and audible noise can be heard from LPFC, it is necessary to decrease LPFC.

- 7) Set ROL4 to set the End of life protection to a percentage of the lamp voltage. For example, to set the protection threshold to 20% of the lamp voltage:

With the first method: $\{(V_{pk\text{lamp}}) \times 20/100\} \times REOL4 / (REOL4 + REOL1 + REOL2 + REOL3)$ should give approximately 7V.

With the second method: The value of REOL4 is chosen to have the SD pin varying between 2-0.7V and 2+0.7 during normal operations and exceeding the window comparator limits (less than 1V or more than 3V) with 30% change in the voltage of the lamp.

(Fine tuning of this threshold can be done by trying different REOL4 values on the test bench)