

### FEATURES

- High-speed access time: 10, 12, 15, and 20 ns
- CMOS low power operation
  - 450 mW (typical) operating
  - 250  $\mu$ W (typical) standby
- TTL compatible interface levels
- Single 5V  $\pm$  10% power supply
- I/O compatible with 3.3V device
- Fully static operation: no clock or refresh required
- Three state outputs
- Industrial temperature available
- Available in 44-pin 400-mil SOJ package and 44-pin TSOP (Type II)

### DESCRIPTION

The *ISSI* IS61C3216 is a high-speed, 512K static RAM organized as 32,768 words by 16 bits. It is fabricated using *ISSI*'s high-performance CMOS technology. This highly reliable process coupled with innovative circuit design techniques, yields fast access times with low power consumption.

When  $\overline{CE}$  is HIGH (deselected), the device assumes a standby mode at which the power dissipation can be reduced down with CMOS input levels.

Easy memory expansion is provided by using Chip Enable and Output Enable inputs,  $\overline{CE}$  and  $\overline{OE}$ . The active LOW Write Enable ( $\overline{WE}$ ) controls both writing and reading of the memory. A data byte allows Upper Byte ( $\overline{UB}$ ) and Lower Byte ( $\overline{LB}$ ) access.

The IS61C3216 is packaged in the JEDEC standard 44-pin 400-mil SOJ and 44-pin TSOP (Type II).

### FUNCTIONAL BLOCK DIAGRAM

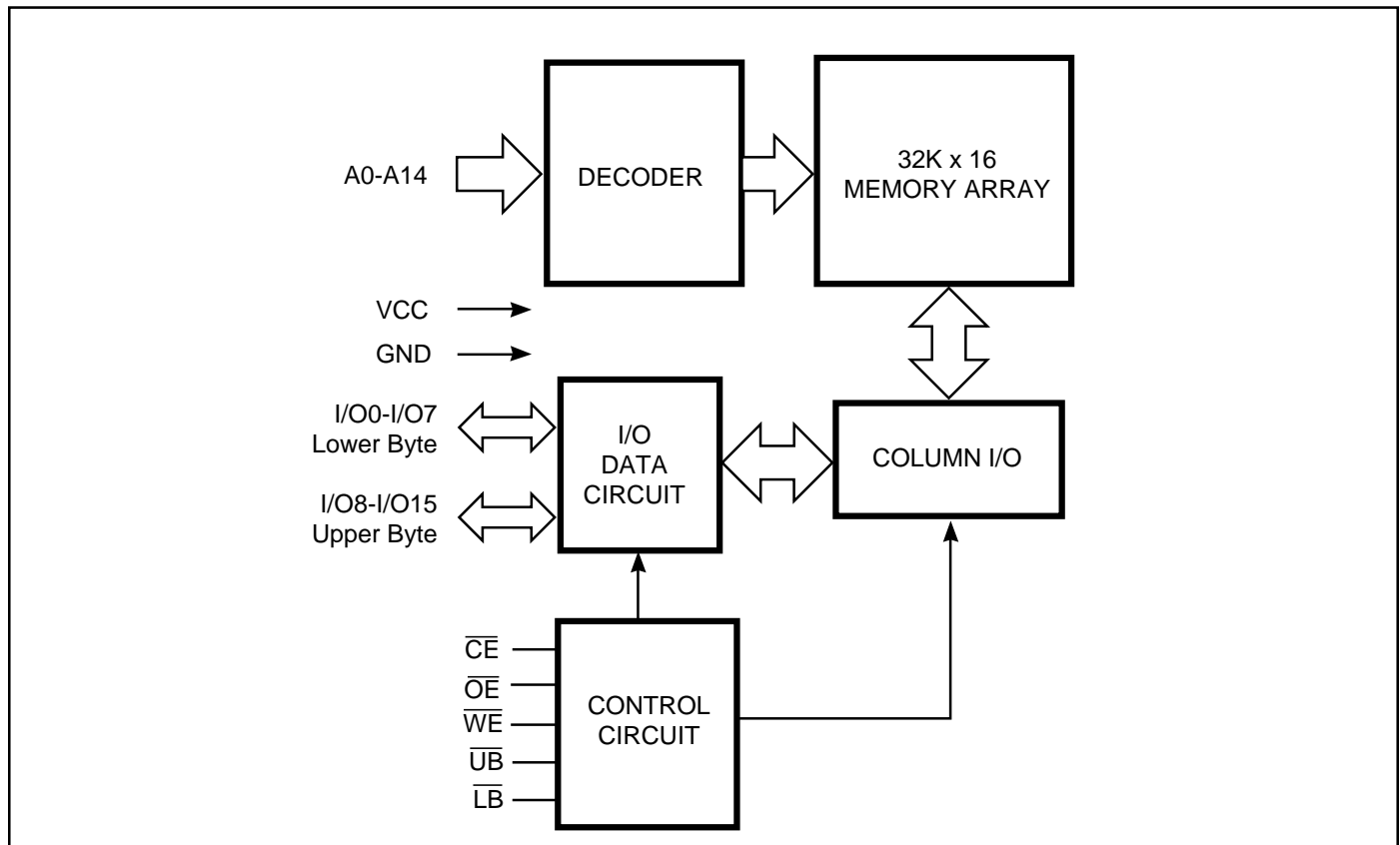

ISSI reserves the right to make changes to its products at any time without notice in order to improve design and supply the best possible product. We assume no responsibility for any errors which may appear in this publication. © Copyright 1997, Integrated Silicon Solution, Inc.

## PIN CONFIGURATIONS

## 44-Pin SOJ

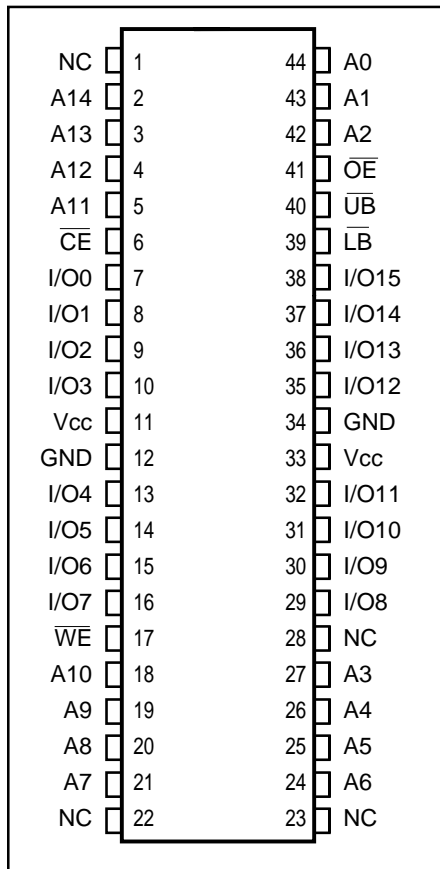

## 44-Pin TSOP (TYPE II)

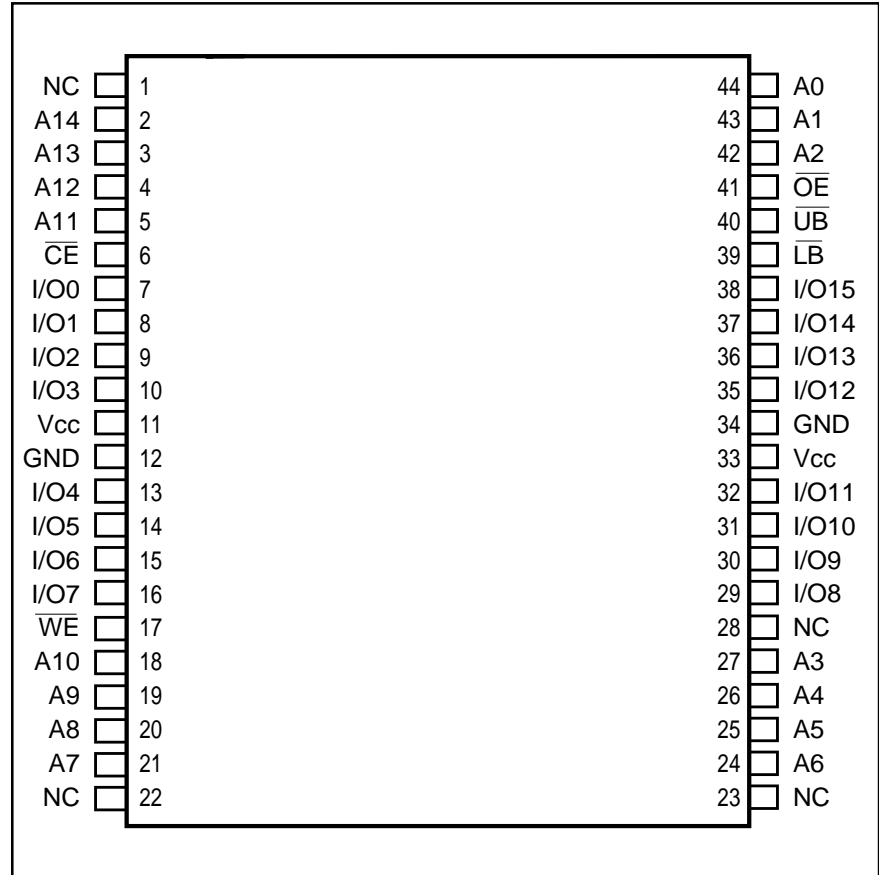

## PIN DESCRIPTIONS

A0-A14	Address Inputs
I/O0-I/O15	Data Inputs/Outputs
$\overline{CE}$	Chip Enable Input
$\overline{OE}$	Output Enable Input
$\overline{WE}$	Write Enable Input

$\overline{LB}$	Lower-byte Control (I/O0-I/O7)
$\overline{UB}$	Upper-byte Control (I/O8-I/O15)
NC	No Connection
Vcc	Power
GND	Ground

## TRUTH TABLE

Mode	$\overline{WE}$	$\overline{CE}$	$\overline{OE}$	$\overline{LB}$	$\overline{UB}$	I/O0-I/O7	I/O8-I/O15	Vcc Current
Not Selected	X	H	X	X	X	High-Z	High-Z	I <sub>SB1</sub> , I <sub>SB2</sub>
Output Disabled	H	L	H	X	X	High-Z	High-Z	I <sub>CC</sub>
	X	L	X	H	H	High-Z	High-Z	
Read	H	L	L	L	H	DOUT	High-Z	I <sub>CC</sub>
	H	L	L	H	L	High-Z	DOUT	
	H	L	L	L	L	DOUT	DOUT	
Write	L	L	X	L	H	DIN	High-Z	I <sub>CC</sub>
	L	L	X	H	L	High-Z	DIN	
	L	L	X	L	L	DIN	DIN	

**ABSOLUTE MAXIMUM RATINGS<sup>(1)</sup>**

Symbol	Parameter	Value	Unit
V <sub>CC</sub>	Supply Voltage with Respect to GND	-0.5 to +7.0	V
V <sub>TERM</sub>	Terminal Voltage with Respect to GND	-0.5 to +7.0	V
T <sub>STG</sub>	Storage Temperature	-65 to +150	°C
P <sub>T</sub>	Power Dissipation	1.5	W
I <sub>OUT</sub>	DC Output Current (LOW)	20	mA

**Note:**

1. Stress greater than those listed under ABSOLUTE MAXIMUM RATINGS may cause permanent damage to the device. This is a stress rating only and functional operation of the device at these or any other conditions above those indicated in the operational sections of this specification is not implied. Exposure to absolute maximum rating conditions for extended periods may affect reliability.

**OPERATING RANGE**

Range	Ambient Temperature	Speed	V <sub>CC</sub>
Commercial	0°C to +70°C	-10, -12	5V ± 5%
		-15, -20	5V ± 10%
Industrial	-40°C to +85°C	-12	5V ± 5%
		-15, -20	5V ± 10%

**DC ELECTRICAL CHARACTERISTICS** (Over Operating Range)

Symbol	Parameter	Test Conditions	Min.	Max.	Unit
V <sub>OH</sub>	Output HIGH Voltage	V <sub>CC</sub> = Min., I <sub>OH</sub> = -4.0 mA	2.4	—	V
V <sub>OL</sub>	Output LOW Voltage	V <sub>CC</sub> = Min., I <sub>OL</sub> = 8.0 mA	—	0.4	V
V <sub>IH</sub>	Input HIGH Voltage		2.2	V <sub>CC</sub> + 0.5	V
V <sub>IL</sub>	Input LOW Voltage <sup>(1)</sup>		-0.5	0.8	V
I <sub>LI</sub>	Input Leakage	GND ≤ V <sub>IN</sub> ≤ V <sub>CC</sub>	-2	2	μA
I <sub>LO</sub>	Output Leakage	GND ≤ V <sub>OUT</sub> ≤ V <sub>CC</sub> , Outputs Disabled	-2	2	μA

**Notes:**

1. V<sub>IL</sub> (min.) = -3.0V for pulse width less than 10 ns.

**POWER SUPPLY CHARACTERISTICS<sup>(1)</sup>** (Over Operating Range)

Symbol	Parameter	Test Conditions	-10		-12		-15		-20		Unit	
			Min.	Max.	Min.	Max.	Min.	Max.	Min.	Max.		
I <sub>CC</sub>	V <sub>CC</sub> Dynamic Operating Supply Current	V <sub>CC</sub> = Max., I <sub>OUT</sub> = 0 mA, f = f <sub>MAX</sub>	Com.	—	300	—	270	—	250	—	230	mA
			Ind.	—	—	—	300	—	270	—	250	
I <sub>SB1</sub>	TTL Standby Current (TTL Inputs)	V <sub>CC</sub> = Max., V <sub>IN</sub> = V <sub>IH</sub> or V <sub>IL</sub> C <sub>E</sub> ≥ V <sub>IH</sub> , f = 0	Com.	—	40	—	40	—	40	—	40	mA
			Ind.	—	—	—	45	—	45	—	45	
I <sub>SB2</sub>	CMOS Standby Current (CMOS Inputs)	V <sub>CC</sub> = Max., C <sub>E</sub> ≥ V <sub>CC</sub> - 0.2V, V <sub>IN</sub> ≥ V <sub>CC</sub> - 0.2V, or V <sub>IN</sub> ≤ 0.2V, f = 0	Com.	—	5	—	5	—	5	—	5	mA
			Ind.	—	—	—	10	—	10	—	10	

**Note:**

1. At f = f<sub>MAX</sub>, address and data inputs are cycling at the maximum frequency, f = 0 means no input lines change.

CAPACITANCE<sup>(1)</sup>

Symbol	Parameter	Conditions	Max.	Unit
C <sub>IN</sub>	Input Capacitance	V <sub>IN</sub> = 0V	6	pF
C <sub>OUT</sub>	Input/Output Capacitance	V <sub>OUT</sub> = 0V	8	pF

**Note:**

1. Tested initially and after any design or process changes that may affect these parameters.

READ CYCLE SWITCHING CHARACTERISTICS<sup>(1)</sup> (Over Operating Range)

Symbol	Parameter	-10		-12		-15		-20		Unit
		Min.	Max.	Min.	Max.	Min.	Max.	Min.	Max.	
t <sub>RC</sub>	Read Cycle Time	10	—	12	—	15	—	20	—	ns
t <sub>AA</sub>	Address Access Time	—	10	—	12	—	15	—	20	ns
t <sub>OH</sub>	Output Hold Time	3	—	3	—	3	—	3	—	ns
t <sub>ACE</sub>	$\overline{CE}$ Access Time	—	10	—	12	—	15	—	20	ns
t <sub>DOE</sub>	$\overline{OE}$ Access Time	—	5	—	5	—	7	—	8	ns
t <sub>HZOE</sub> <sup>(2)</sup>	$\overline{OE}$ to High-Z Output	0	5	0	6	0	7	—	8	ns
t <sub>LZOE</sub> <sup>(2)</sup>	$\overline{OE}$ to Low-Z Output	0	—	0	—	0	—	0	—	ns
t <sub>HZCE</sub> <sup>(2)</sup>	$\overline{CE}$ to High-Z Output	0	5	0	6	0	7	0	8	ns
t <sub>LZCE</sub> <sup>(2)</sup>	$\overline{CE}$ to Low-Z Output	4	—	4	—	4	—	4	—	ns
t <sub>BA</sub>	$\overline{LB}$ , $\overline{UB}$ Access Time	—	5	—	6	—	7	—	8	ns
t <sub>HZB</sub>	$\overline{LB}$ , $\overline{UB}$ to High-Z Output	0	5	0	6	0	7	—	8	ns
t <sub>LZB</sub>	$\overline{LB}$ , $\overline{UB}$ to Low-Z Output	5	—	5	—	5	—	5	—	ns

**Notes:**

1. Test conditions assume signal transition times of 3 ns or less, timing reference levels of 1.5V, input pulse levels of 0 to 3.0V and output loading specified in Figure 1a.
2. Tested with the load in Figure 1b. Transition is measured  $\pm 500$  mV from steady-state voltage. Not 100% tested.
3. Not 100% tested.

## AC TEST CONDITIONS

Parameter	Unit
Input Pulse Level	0V to 3.0V
Input Rise and Fall Times	3 ns
Input and Output Timing and Reference Level	1.5V
Output Load	See Figures 1a and 1b

## AC TEST LOADS

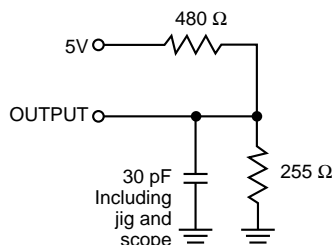

Figure 1a.

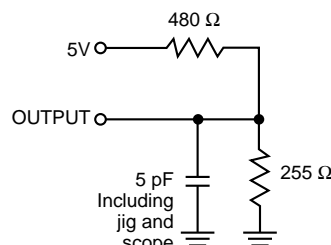
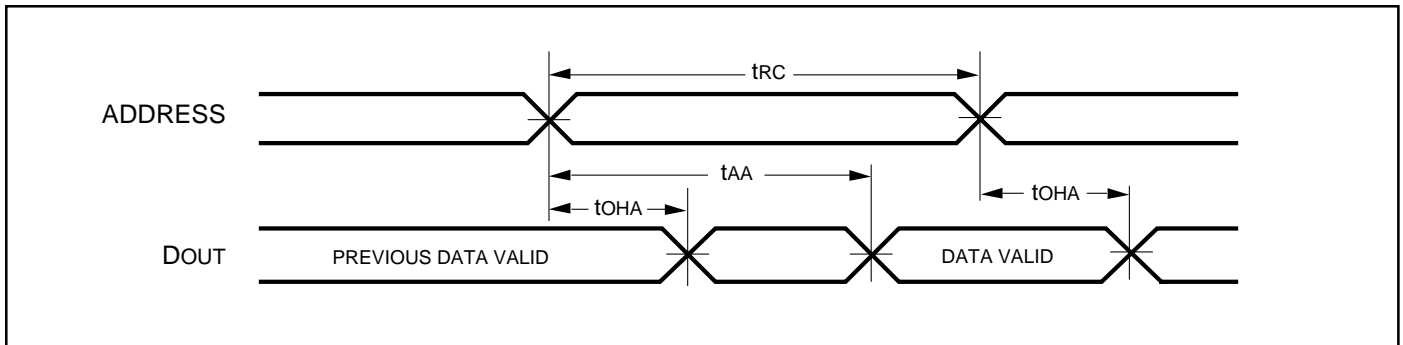
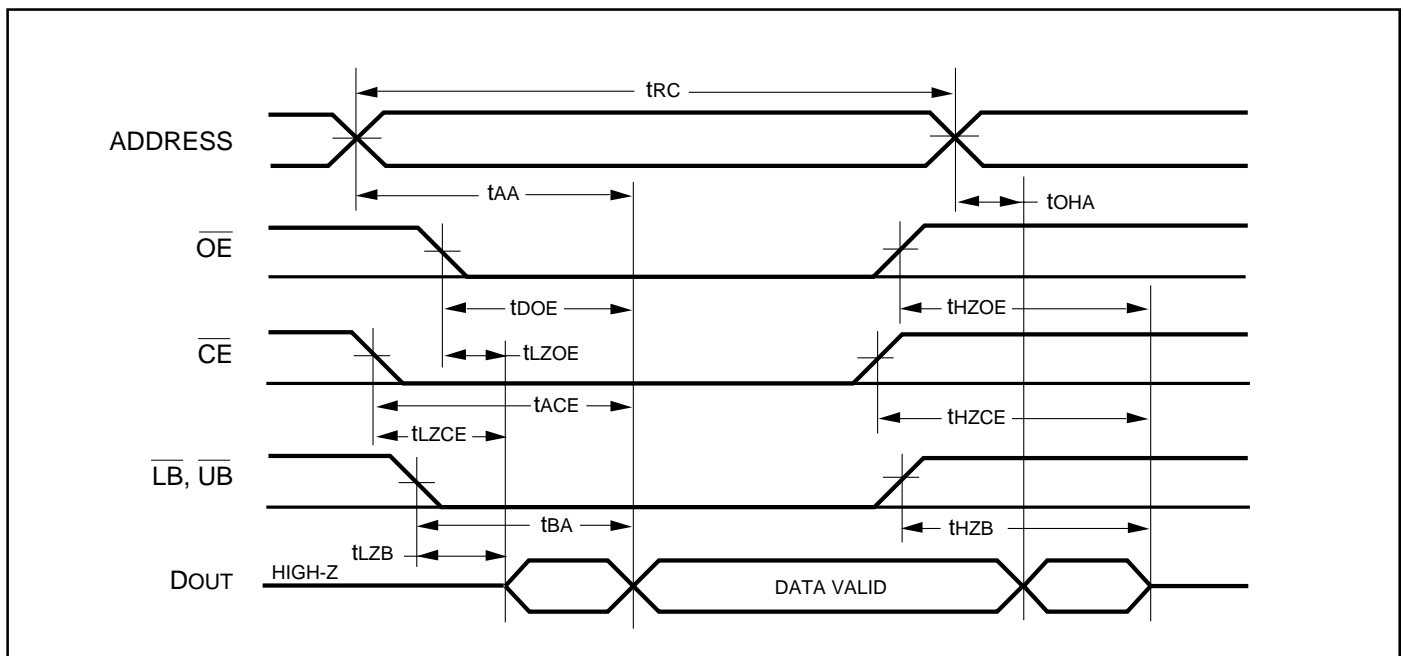

Figure 1b.

## AC WAVEFORMS

READ CYCLE NO. 1<sup>(1,2)</sup> (Address Controlled) ( $\overline{CE} = \overline{OE} = V_{IL}$ ,  $\overline{UB}$  or  $\overline{LB} = V_{IL}$ )READ CYCLE NO. 2<sup>(1,3)</sup>

## Notes:

1.  $\overline{WE}$  is HIGH for a Read Cycle.
2. The device is continuously selected.  $\overline{OE}$ ,  $\overline{CE}$ ,  $\overline{UB}$ , or  $\overline{LB} = V_{IL}$ .
3. Address is valid prior to or coincident with  $\overline{CE}$  LOW transition.

**WRITE CYCLE SWITCHING CHARACTERISTICS<sup>(1,3)</sup>** (Over Operating Range)

Symbol	Parameter	-10		-12		-15		-20		Unit
		Min.	Max.	Min.	Max.	Min.	Max.	Min.	Max.	
t <sub>WC</sub>	Write Cycle Time	10	—	12	—	15	—	20	—	ns
t <sub>SCE</sub>	$\overline{\text{CE}}$ to Write End	9	—	10	—	11	—	12	—	ns
t <sub>AW</sub>	Address Setup Time to Write End	9	—	10	—	11	—	12	—	ns
t <sub>HA</sub>	Address Hold from Write End	1	—	1	—	1	—	1	—	ns
t <sub>SA</sub>	Address Setup Time	0	—	0	—	0	—	0	—	ns
t <sub>PWB</sub>	$\overline{\text{LB}}$ , $\overline{\text{UB}}$ Valid to End of Write	9	—	10	—	11	—	12	—	ns
t <sub>PWE</sub>	$\overline{\text{WE}}$ Pulse Width	7	—	8	—	10	—	11	—	ns
t <sub>SD</sub>	Data Setup to Write End	5	—	6	—	7	—	8	—	ns
t <sub>HD</sub>	Data Hold from Write End	0	—	0	—	0	—	0	—	ns
t <sub>HZWE<sup>(2)</sup></sub>	$\overline{\text{WE}}$ LOW to High-Z Output	—	5	—	6	—	7	—	8	ns
t <sub>LZWE<sup>(2)</sup></sub>	$\overline{\text{WE}}$ HIGH to Low-Z Output	1	—	1	—	1	—	1	—	ns

**Notes:**

1. Test conditions assume signal transition times of 3 ns or less, timing reference levels of 1.5V, input pulse levels of 0 to 3.0V and output loading specified in Figure 1a.
2. Tested with the load in Figure 1b. Transition is measured  $\pm 500$  mV from steady-state voltage. Not 100% tested.
3. The internal write time is defined by the overlap of  $\overline{\text{CE}}$  LOW and  $\overline{\text{UB}}$  or  $\overline{\text{LB}}$ , and  $\overline{\text{WE}}$  LOW. All signals must be in valid states to initiate a Write, but any one can go inactive to terminate the Write. The Data Input Setup and Hold timing are referenced to the rising or falling edge of the signal that terminates the write.

## AC WAVEFORMS

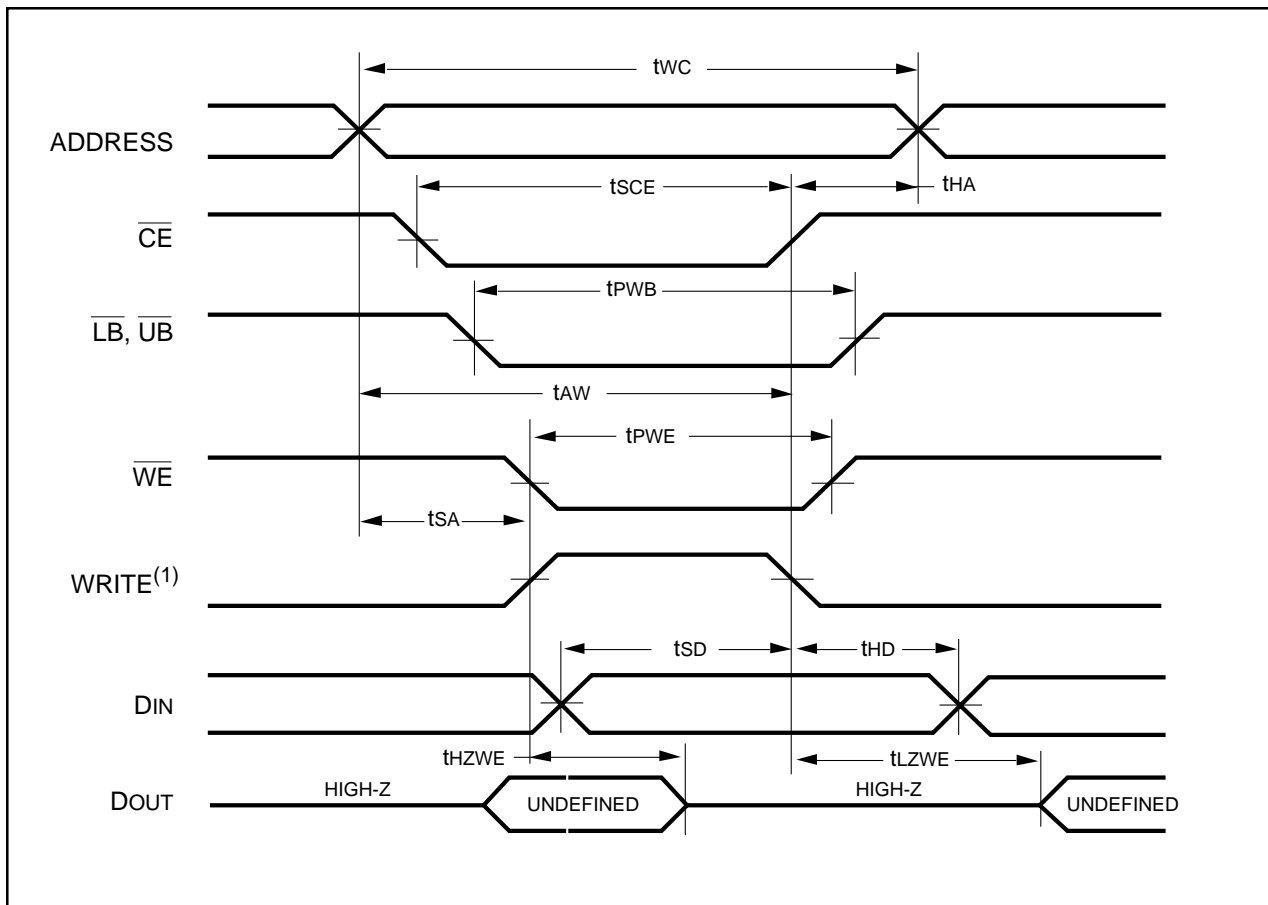
WRITE CYCLE NO. 1 ( $\overline{WE}$  Controlled)<sup>(1,2)</sup>**Notes:**

1. WRITE is an internally generated signal asserted during an overlap of the LOW states on the  $\overline{CE}$  and  $\overline{WE}$  inputs and at least one of the  $\overline{LB}$  and  $\overline{UB}$  inputs being in the LOW state.
2.  $WRITE = (\overline{CE}) [ (\overline{LB}) = (\overline{UB}) ] (\overline{WE})$ .

**ORDERING INFORMATION****Commercial Range: 0°C to +70°C**

Speed (ns)	Order Part No.	Package
10	IS61C3216-10T IS61C3216-10K	Plastic TSOP (Type II) 400-mil Plastic SOJ
12	IS61C3216-12T IS61C3216-12K	Plastic TSOP (Type II) 400-mil Plastic SOJ
15	IS61C3216-15T IS61C3216-15K	Plastic TSOP (Type II) 400-mil Plastic SOJ
20	IS61C3216-20T IS61C3216-20K	Plastic TSOP (Type II) 400-mil Plastic SOJ

**ORDERING INFORMATION****Industrial Range: -40°C to +85°C**

Speed (ns)	Order Part No.	Package
12	IS61C3216-12TI IS61C3216-12KI	Plastic TSOP (Type II) 400-mil Plastic SOJ
15	IS61C3216-15TI IS61C3216-15KI	Plastic TSOP (Type II) 400-mil Plastic SOJ
20	IS61C3216-20TI IS61C3216-20KI	Plastic TSOP (Type II) 400-mil Plastic SOJ

ISSI®

***Integrated Silicon Solution, Inc.***

2231 Lawson Lane  
 Santa Clara, CA 95054  
 Tel: 1-800-379-4774  
 Fax: (408) 588-0806  
 e-mail: sales@issiusa.com  
<http://www.issiusa.com>

***Integrated Silicon Solution, Inc.***

SR007-1B  
 01/26/98