

# IS61SP12832



## 128K x 32 SYNCHRONOUS PIPELINED STATIC RAM

ADVANCE INFORMATION  
APRIL 1999

### FEATURES

- Internal self-timed write cycle
- Individual Byte Write Control and Global Write
- Clock controlled, registered address, data and control
- Pentium™ or linear burst sequence control using MODE input
- Three chip enables for simple depth expansion and address pipelining
- Common data inputs and data outputs
- JEDEC 100-Pin TQFP and 119-pin PBGA package
- Single +3.3V, +10%, -5% power supply
- Power-down snooze mode

### DESCRIPTION

The *ISSI* IS61SP12832 is a high-speed, low-power synchronous static RAM designed to provide a burstable, high-performance, secondary cache for the Pentium™, 680X0™, and PowerPC™ microprocessors. It is organized as 131,072 words by 32 bits, fabricated with *ISSI*'s advanced CMOS technology. The device integrates a 2-bit burst counter, high-speed SRAM core, and high-drive capability outputs into a single monolithic circuit. All synchronous inputs pass through registers controlled by a positive-edge-triggered single clock input.

Write cycles are internally self-timed and are initiated by the rising edge of the clock input. Write cycles can be from one to four bytes wide as controlled by the write control inputs.

Separate byte enables allow individual bytes to be written. BW1 controls DQa, BW2 controls DQb, BW3 controls DQc, BW4 controls DQd, conditioned by BWE being LOW. A LOW on GW input would cause all bytes to be written.

Bursts can be initiated with either ADSP (Address Status Processor) or ADSC (Address Status Cache Controller) input pins. Subsequent burst addresses can be generated internally by the IS61SP12832 and controlled by the ADV (burst address advance) input pin.

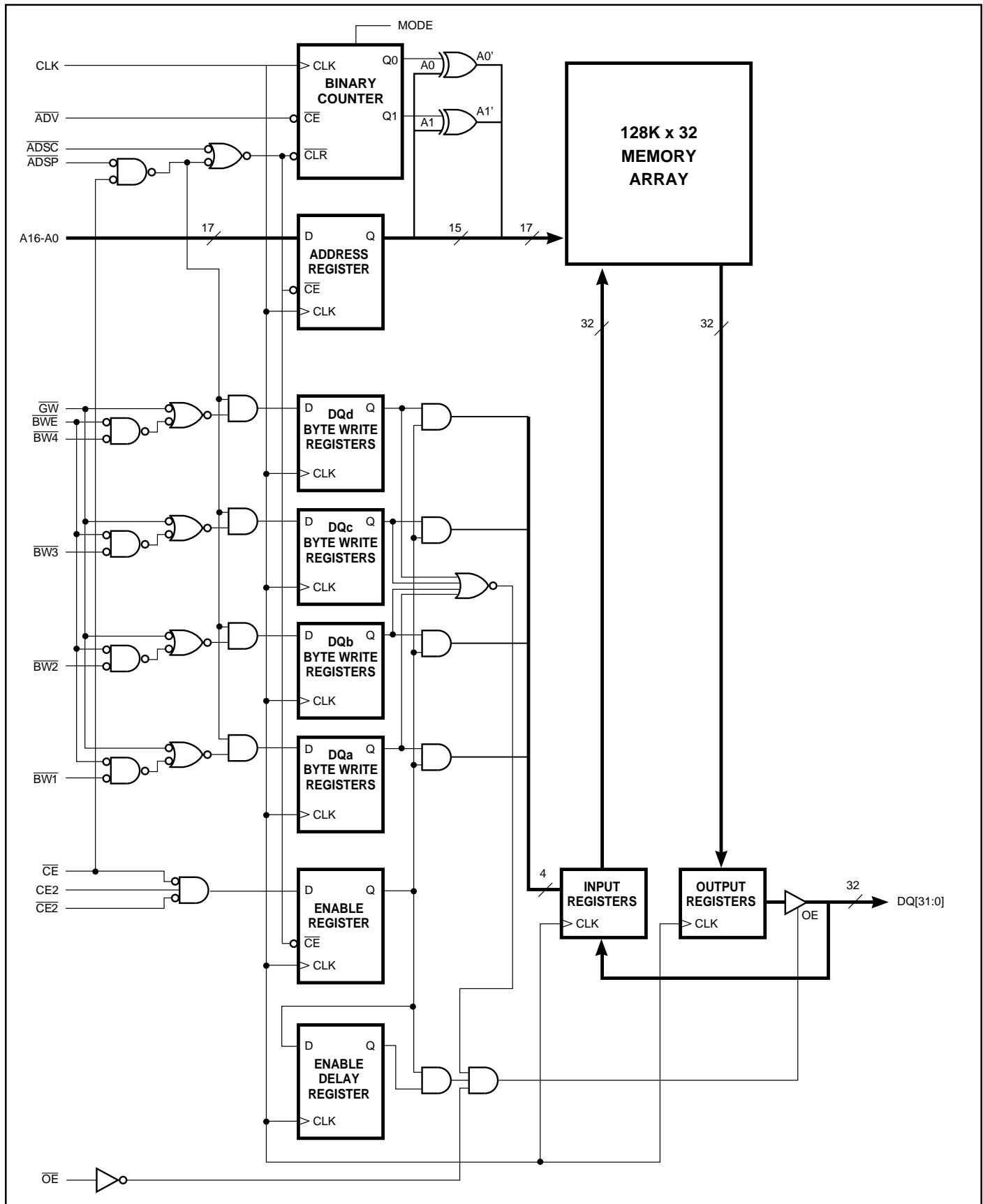
The mode pin is used to select the burst sequence order, Linear burst is achieved when this pin is tied LOW. Interleave burst is achieved when this pin is tied HIGH or left floating.

### FAST ACCESS TIME

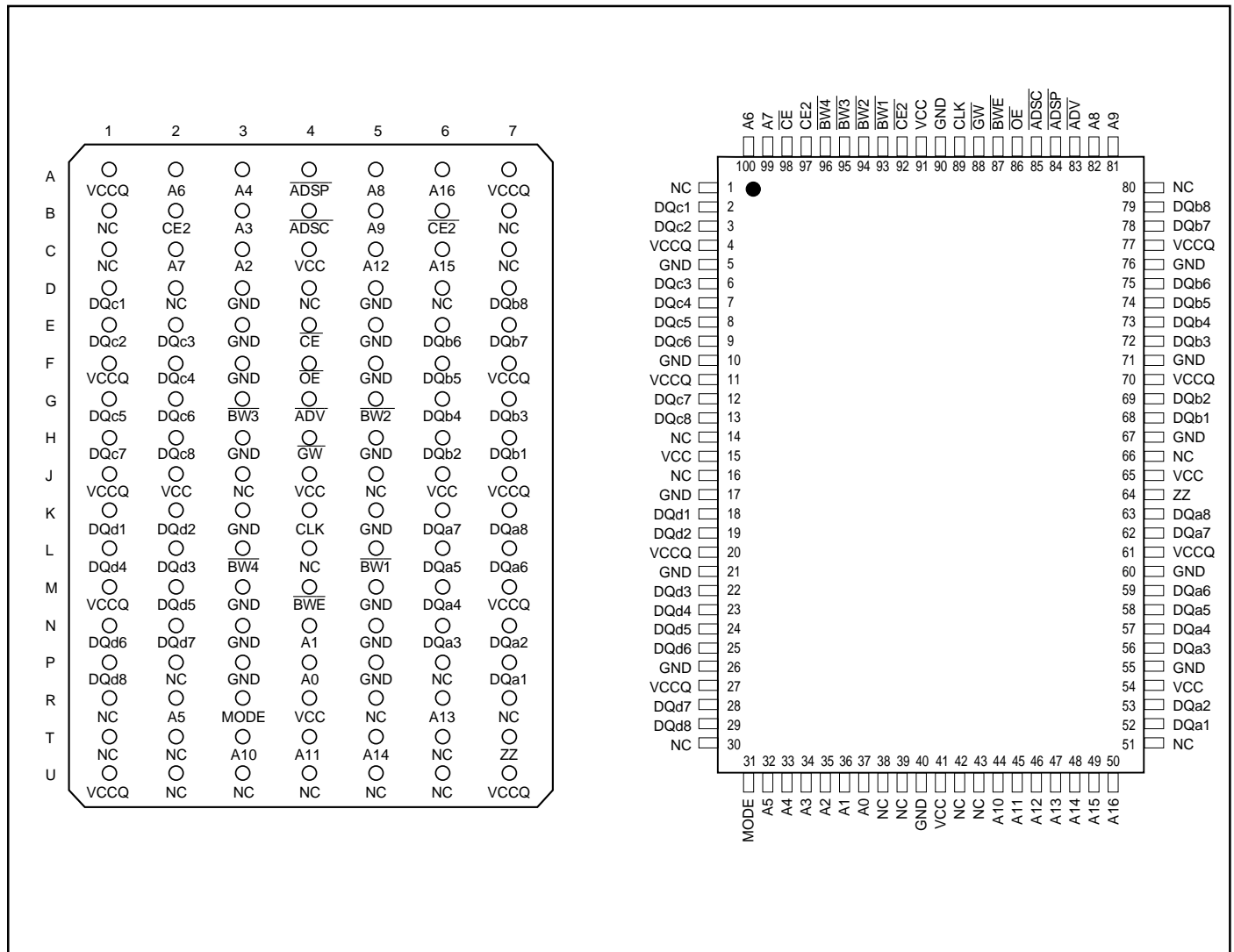
Symbol	Parameter	-166	-150	-133	-117	-5	Units
tkQ	Clock Access Time	3.5	3.8	4	4	5	ns
tkC	Cycle Time	6	6.7	7.5	8.5	10	ns
	Frenquency	166	150	133	117	100	MHz

This document contains ADVANCE INFORMATION data. ISSI reserves the right to make changes to its products at any time without notice in order to improve design and supply the best possible product. We assume no responsibility for any errors which may appear in this publication. © Copyright 1998, Integrated Silicon Solution, Inc.

BLOCK DIAGRAM



**PIN CONFIGURATION**  
**119-pin PBGA (Top View) and 100-Pin TQFP**



**PIN DESCRIPTIONS**

A0, A1	Synchronous Address Inputs. These pins must tied to the two LSBs of the address bus.	$\overline{GW}$	Synchronous Global Write Enable
A2-A16	Synchronous Address Inputs	$\overline{CE}$ , $\overline{CE2}$ , CE2	Synchronous Chip Enable
CLK	Synchronous Clock	$\overline{OE}$	Output Enable
$\overline{ADSP}$	Synchronous Processor Address Status	DQa-DQd	Synchronous Data Input/Output
$\overline{ADSC}$	Synchronous Controller Address Status	MODE	Burst Sequence Mode Selection
$\overline{ADV}$	Synchronous Burst Address Advance	Vcc	+3.3V Power Supply
$\overline{BW1}$ - $\overline{BW4}$	Synchronous Byte Write Enable	GND	Ground
$\overline{BWE}$	Synchronous Byte Write Enable	Vccq	Isolated Output Buffer Supply: +3.3V
		ZZ	Snooze Enable
		GNDq	Isolated Output Buffer Ground

## TRUTH TABLE

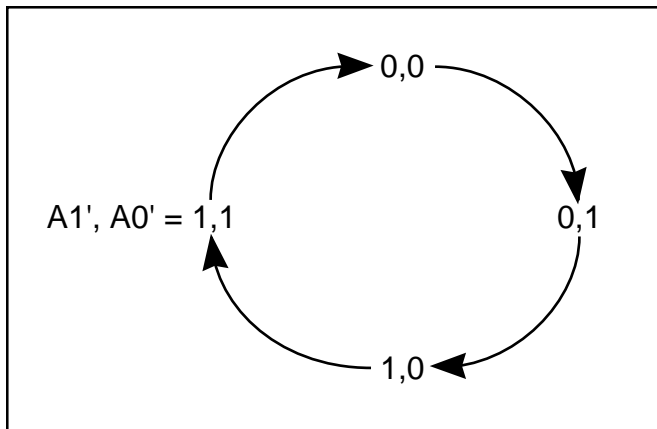
Operation	Address Used	$\overline{CE}$	CE2	$\overline{CE2}$	$\overline{ADSP}$	$\overline{ADSC}$	$\overline{ADV}$	$\overline{WRITE}$	$\overline{OE}$	DQ
Deselected, Power-down	None	H	X	X	X	L	X	X	X	High-Z
Deselected, Power-down	None	L	X	H	L	X	X	X	X	High-Z
Deselected, Power-down	None	L	L	X	L	X	X	X	X	High-Z
Deselected, Power-down	None	X	X	H	H	L	X	X	X	High-Z
Deselected, Power-down	None	X	0	X	H	L	X	X	X	High-Z
Read Cycle, Begin Burst	External	L	H	L	L	X	X	X	X	High-Z
Read Cycle, Begin Burst	External	L	H	L	H	0	X	Read	X	High-Z
Write Cycle, Begin Burst	External	L	H	L	H	L	X	Write	X	High-Z
Read Cycle, Continue Burst	Next	X	X	X	H	H	L	Read	L	Q
Read Cycle, Continue Burst	Next	X	X	X	H	H	L	Read	H	High-Z
Read Cycle, Continue Burst	Next	H	X	X	X	H	L	Read	L	Q
Read Cycle, Continue Burst	Next	H	X	X	X	H	L	Read	H	High-Z
Write Cycle, Continue Burst	Next	X	X	X	H	H	L	Write	X	High-Z
Write Cycle, Continue Burst	Next	H	X	X	X	H	L	Write	X	High-Z
Read Cycle, Suspend Burst	Current	X	X	X	H	H	H	Read	L	Q
Read Cycle, Suspend Burst	Current	X	X	X	H	H	H	Read	H	High-Z
Read Cycle, Suspend Burst	Current	H	X	X	X	H	H	Read	L	Q
Read Cycle, Suspend Burst	Current	H	X	X	X	H	H	Read	H	High-Z
Write Cycle, Suspend Burst	Current	X	X	X	H	H	H	Write	X	High-Z
Write Cycle, Suspend Burst	Current	H	X	X	X	H	H	Write	X	High-Z

## PARTIAL TRUTH TABLE

Function	$\overline{GW}$	$\overline{BWE}$	$\overline{BW1}$	$\overline{BW2}$	$\overline{BW3}$	$\overline{BW4}$
Read	H	H	X	X	X	X
Read	H	L	H	H	H	H
Write Byte 1	H	L	L	H	H	H
Write All Bytes	H	L	L	L	L	L
Write All Bytes	L	X	X	X	X	X

**INTERLEAVED BURST ADDRESS TABLE (MODE = V<sub>CCQ</sub> or No Connect)**

External Address A1 A0	1st Burst Address A1 A0	2nd Burst Address A1 A0	3rd Burst Address A1 A0
00	01	10	11
01	00	11	10
10	11	00	01
11	10	01	00

**LINEAR BURST ADDRESS TABLE (MODE = GND<sub>Q</sub>)****ABSOLUTE MAXIMUM RATINGS<sup>(1)</sup>**

Symbol	Parameter	Value	Unit
T <sub>BIAS</sub>	Temperature Under Bias	-40 to +85	°C
T <sub>STG</sub>	Storage Temperature	-55 to +150	°C
P <sub>D</sub>	Power Dissipation	1.6	W
I <sub>OUT</sub>	Output Current (per I/O)	100	mA
V <sub>IN</sub> , V <sub>OUT</sub>	Voltage Relative to GND for I/O Pins	-0.5 to V <sub>CCQ</sub> + 0.3	V
V <sub>IN</sub>	Voltage Relative to GND for for Address and Control Inputs	-0.5 to V <sub>CC</sub> + 0.5	V
V <sub>CC</sub>	Voltage on V <sub>CC</sub> Supply Relative to GND	-0.5 to 4.6	V

**Notes:**

1. Stress greater than those listed under ABSOLUTE MAXIMUM RATINGS may cause permanent damage to the device. This is a stress rating only and functional operation of the device at these or any other conditions above those indicated in the operational sections of this specification is not implied. Exposure to absolute maximum rating conditions for extended periods may affect reliability.
2. This device contains circuitry to protect the inputs against damage due to high static voltages or electric fields; however, precautions may be taken to avoid application of any voltage higher than maximum rated voltages to this high-impedance circuit.
3. This device contains circuitry that will ensure the output devices are in High-Z at power up.

## OPERATING RANGE

Range	Ambient Temperature	V <sub>CC</sub>
Commercial	0°C to +70°C	3.3V, +10%, -5%
Industrial	-40°C to +85°C	3.3V, +10%, -5%

DC ELECTRICAL CHARACTERISTICS<sup>(1)</sup> (Over Operating Range)

Symbol	Parameter	Test Conditions	Min.	Max.	Unit
V <sub>OH</sub>	Output HIGH Voltage	I <sub>OH</sub> = -4.0 mA	2.4	—	V
V <sub>OL</sub>	Output LOW Voltage	I <sub>OL</sub> = 8.0 mA	—	0.4	V
V <sub>IH</sub>	Input HIGH Voltage		2.0	V <sub>CCQ</sub> + 0.3	V
V <sub>IL</sub>	Input LOW Voltage		-0.3	0.8	V
I <sub>LI</sub>	Input Leakage Current	GND ≤ V <sub>IN</sub> ≤ V <sub>CCQ</sub> <sup>(2)</sup>	Com. Ind.	-2 5	μA
I <sub>LO</sub>	Output Leakage Current	GND ≤ V <sub>OUT</sub> ≤ V <sub>CCQ</sub> , $\overline{OE} = V_{IH}$	Com. Ind.	-2 5	μA

## POWER SUPPLY CHARACTERISTICS (Over Operating Range)

Symbol	Parameter	Test Conditions	-166		-150		-133		-117		-5		Unit	
			Typ.	Max.	Typ.	Max.	Typ.	Max.	Typ.	Max.	Typ.	Max.		
I <sub>CC</sub>	AC Operating Supply Current	Device Selected, All Inputs = V <sub>IL</sub> or V <sub>IH</sub> $\overline{OE} = V_{IH}$ , V <sub>CC</sub> = Max. Cycle Time ≥ t <sub>kc</sub> min.	Com.	200	230	190	220	180	210	175	205	170	200	mA
			Ind.	—	—	200	230	190	220	185	215	180	210	mA
I <sub>SB</sub>	Standby Current	Device Deselected, V <sub>CC</sub> = Max., All Inputs = V <sub>IH</sub> or V <sub>IL</sub> CLK Cycle Time ≥ t <sub>kc</sub> min.	Com.	45	70	45	70	45	70	45	65	45	65	mA
			Ind.	—	—	50	80	50	80	50	75	50	75	mA
I <sub>ZZ</sub>	Power-down Mode Current	ZZ = V <sub>CCQ</sub> Clock Running All Inputs ≤ GND + 0.2V or ≥ V <sub>CC</sub> - 0.2V	Com.	—	5	—	5	—	5	—	5	—	5	mA
			Ind.	—	15	—	15	—	15	—	15	—	15	mA

## Notes:

1. The MODE pin has an internal pullup. This pin may be a No Connect, tied to GND, or tied to V<sub>CCQ</sub>.
2. The MODE pin should be tied to V<sub>CC</sub> or GND. It exhibits ±10 μA maximum leakage current when tied to ≤ GND + 0.2V or ≥ V<sub>CC</sub> - 0.2V.

**CAPACITANCE<sup>(1,2)</sup>**

Symbol	Parameter	Conditions	Max.	Unit
C <sub>IN</sub>	Input Capacitance	V <sub>IN</sub> = 0V	5	pF
C <sub>OUT</sub>	Input/Output Capacitance	V <sub>OUT</sub> = 0V	8	pF

**Notes:**

1. Tested initially and after any design or process changes that may affect these parameters.
2. Test conditions: T<sub>A</sub> = 25°C, f = 1 MHz, V<sub>CC</sub> = 3.3V.

**AC TEST CONDITIONS**

Parameter	Unit
Input Pulse Level	0V to 3.0V
Input Rise and Fall Times	1.5 ns
Input and Output Timing and Reference Level	1.5V
Output Load	See Figures 1 and 2

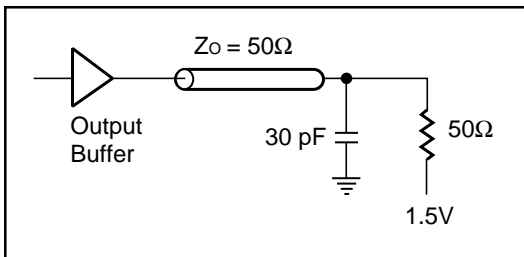
**AC TEST LOADS**

Figure 1

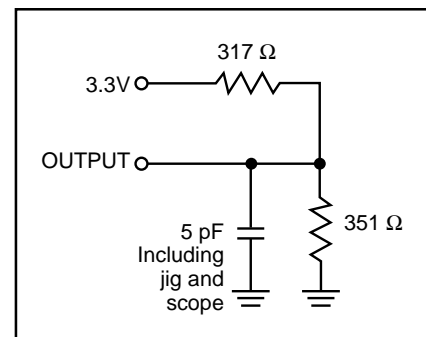


Figure 2

**READ/WRITE CYCLE SWITCHING CHARACTERISTICS** (Over Operating Range)

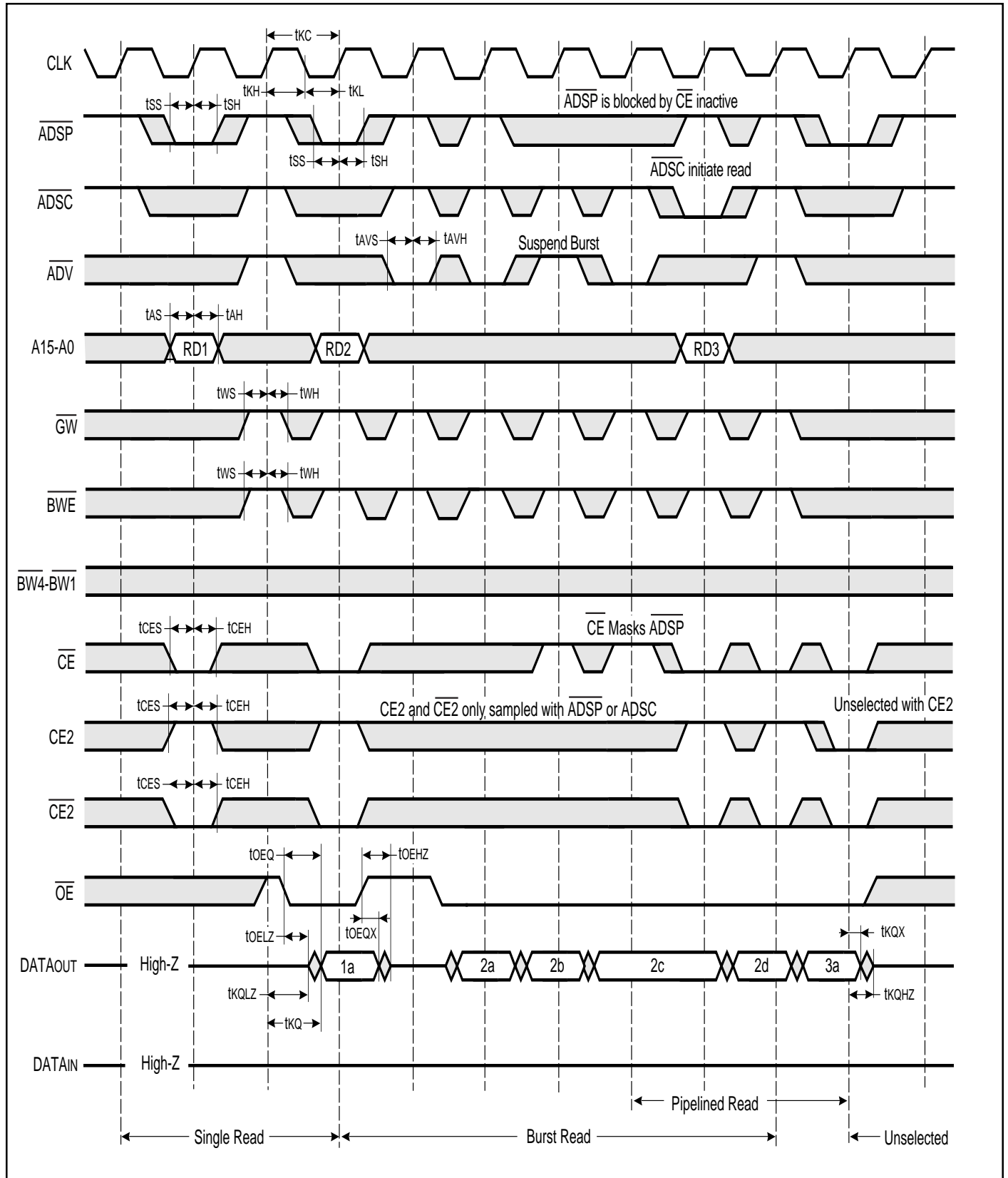
Symbol	Parameter	-166		-150		-133		-117		-5		Unit
		Min.	Max.	Min.	Max.	Min.	Max.	Min.	Max.	Min.	Max.	
f <sub>MAX</sub>	Clock Frequency	—	166	—	150	—	133	—	117	—	100	MHz
t <sub>KC</sub>	Cycle Time	6	—	6.7	—	7.5	—	8.5	—	10	—	ns
t <sub>KH</sub>	Clock High Time	2.4	—	2.6	—	2.8	—	3.4	—	4	—	ns
t <sub>KL</sub>	Clock Low Time	2.4	—	2.6	—	2.8	—	3.4	—	4	—	ns
t <sub>KQ</sub>	Clock Access Time	—	3.5	—	3.8	—	4	—	4	—	5	ns
t <sub>KQX</sub> <sup>(1)</sup>	Clock High to Output Invalid	1.5	—	1.5	—	1.5	—	1.5	—	2.5	—	ns
t <sub>KQLZ</sub> <sup>(1,2)</sup>	Clock High to Output Low-Z	0	—	0	—	0	—	0	—	0	—	ns
t <sub>KQHZ</sub> <sup>(1,2)</sup>	Clock High to Output High-Z	1.5	6	1.5	6.7	1.5	7.5	1.5	8.5	1.5	10	ns
t <sub>OEQ</sub>	Output Enable to Output Valid	—	3.5	—	3.5	—	3.8	—	4	—	5	ns
t <sub>OEQX</sub> <sup>(1)</sup>	Output Disable to Output Invalid	0	—	0	—	0	—	0	—	0	—	ns
t <sub>OEZ</sub> <sup>(1,2)</sup>	Output Enable to Output Low-Z	0	—	0	—	0	—	0	—	0	—	ns
t <sub>OEHZ</sub> <sup>(1,2)</sup>	Output Disable to Output High-Z	2	3.5	2	3.5	2	3.8	2	4	2	5	ns
t <sub>AS</sub>	Address Setup Time	1.5	—	1.5	—	1.5	—	1.5	—	1.5	—	ns
t <sub>SS</sub>	Address Status Setup Time	1.5	—	1.5	—	1.5	—	1.5	—	1.5	—	ns
t <sub>WS</sub>	Write Setup Time	1.5	—	1.5	—	1.5	—	1.5	—	1.5	—	ns
t <sub>CES</sub>	Chip Enable Setup Time	1.5	—	1.5	—	1.5	—	1.5	—	1.5	—	ns
t <sub>AVS</sub>	Address Advance Setup Time	1.5	—	1.5	—	1.5	—	1.5	—	1.5	—	ns
t <sub>AH</sub>	Address Hold Time	0.5	—	0.5	—	0.5	—	0.5	—	0.5	—	ns
t <sub>SH</sub>	Address Status Hold Time	0.5	—	0.5	—	0.5	—	0.5	—	0.5	—	ns
t <sub>WH</sub>	Write Hold Time	0.5	—	0.5	—	0.5	—	0.5	—	0.5	—	ns
t <sub>CEH</sub>	Chip Enable Hold Time	0.5	—	0.5	—	0.5	—	0.5	—	0.5	—	ns
t <sub>AVH</sub>	Address Advance Hold Time	0.5	—	0.5	—	0.5	—	0.5	—	0.5	—	ns

**Note:**

1. Guaranteed but not 100% tested. This parameter is periodically sampled.
2. Tested with load in Figure 2.



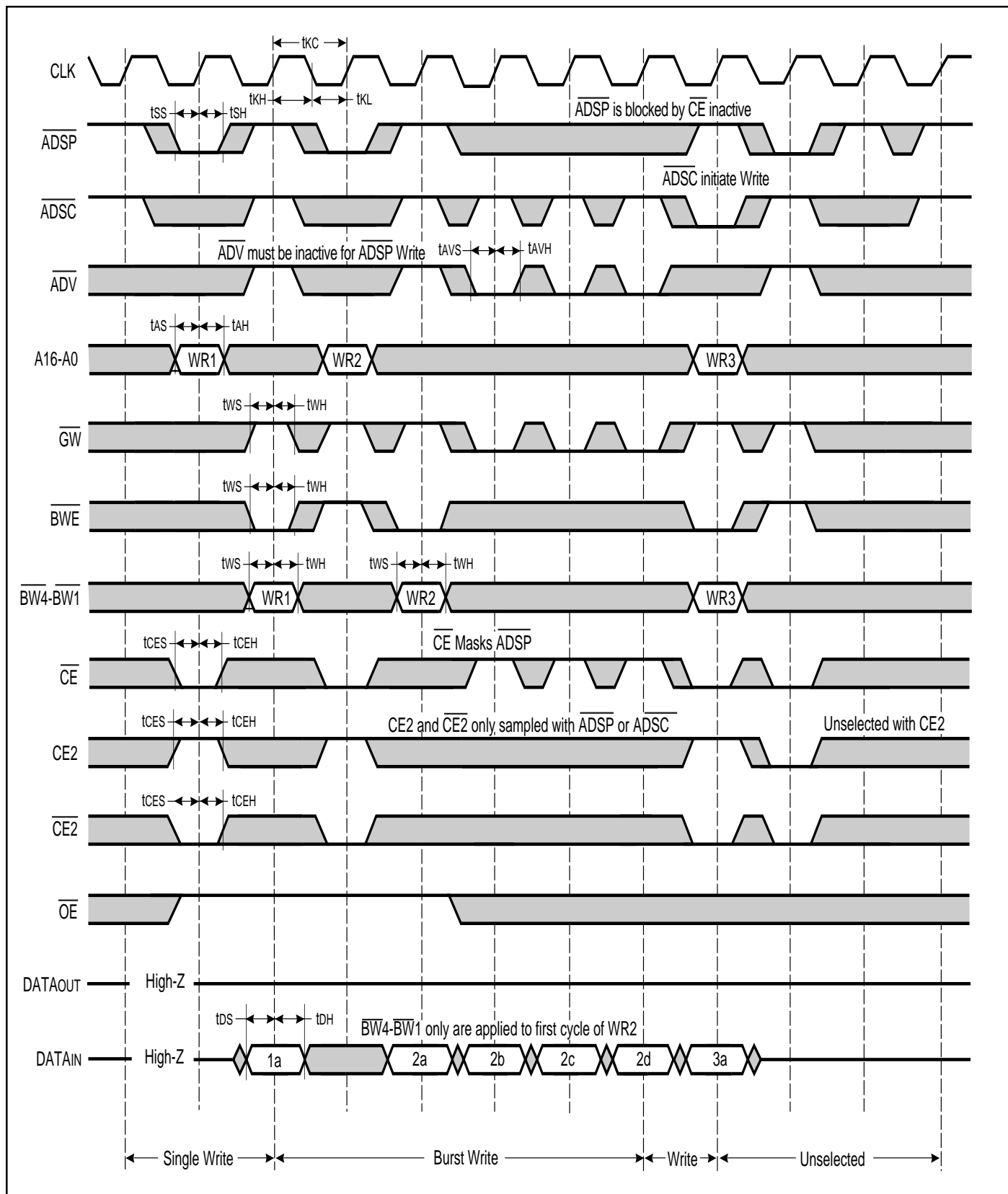
READ/WRITE CYCLE TIMING



**WRITE CYCLE SWITCHING CHARACTERISTICS** (Over Operating Range)

Symbol	Parameter	-166		-150		-133		-117		-5		Unit
		Min.	Max.	Min.	Max.	Min.	Max.	Min.	Max.	Min.	Max.	
t <sub>KC</sub>	Cycle Time	6	—	6.7	—	7.5	—	8.5	—	10	—	ns
t <sub>KH</sub>	Clock High Time	2.4	—	2.6	—	2.8	—	3.4	—	4	—	ns
t <sub>KL</sub>	Clock Low Time	2.4	—	2.6	—	2.8	—	3.4	—	4	—	ns
t <sub>AS</sub>	Address Setup Time	1.5	—	1.5	—	1.5	—	1.5	—	1.5	—	ns
t <sub>SS</sub>	Address Status Setup Time	1.5	—	1.5	—	1.5	—	1.5	—	1.5	—	ns
t <sub>WS</sub>	Write Setup Time	1.5	—	1.5	—	1.5	—	1.5	—	1.5	—	ns
t <sub>DS</sub>	Data In Setup Time	1.5	—	1.5	—	1.5	—	1.5	—	1.5	—	ns
t <sub>CES</sub>	Chip Enable Setup Time	1.5	—	1.5	—	1.5	—	1.5	—	1.5	—	ns
t <sub>AVS</sub>	Address Advance Setup Time	1.5	—	1.5	—	1.5	—	1.5	—	1.5	—	ns
t <sub>AH</sub>	Address Hold Time	0.5	—	0.5	—	0.5	—	0.5	—	0.5	—	ns
t <sub>SH</sub>	Address Status Hold Time	0.5	—	0.5	—	0.5	—	0.5	—	0.5	—	ns
t <sub>DH</sub>	Data In Hold Time	0.5	—	0.5	—	0.5	—	0.5	—	0.5	—	ns
t <sub>WH</sub>	Write Hold Time	0.5	—	0.5	—	0.5	—	0.5	—	0.5	—	ns
t <sub>CEH</sub>	Chip Enable Hold Time	0.5	—	0.5	—	0.5	—	0.5	—	0.5	—	ns
t <sub>AVH</sub>	Address Advance Hold Time	0.5	—	0.5	—	0.5	—	0.5	—	0.5	—	ns

WRITE CYCLE TIMING



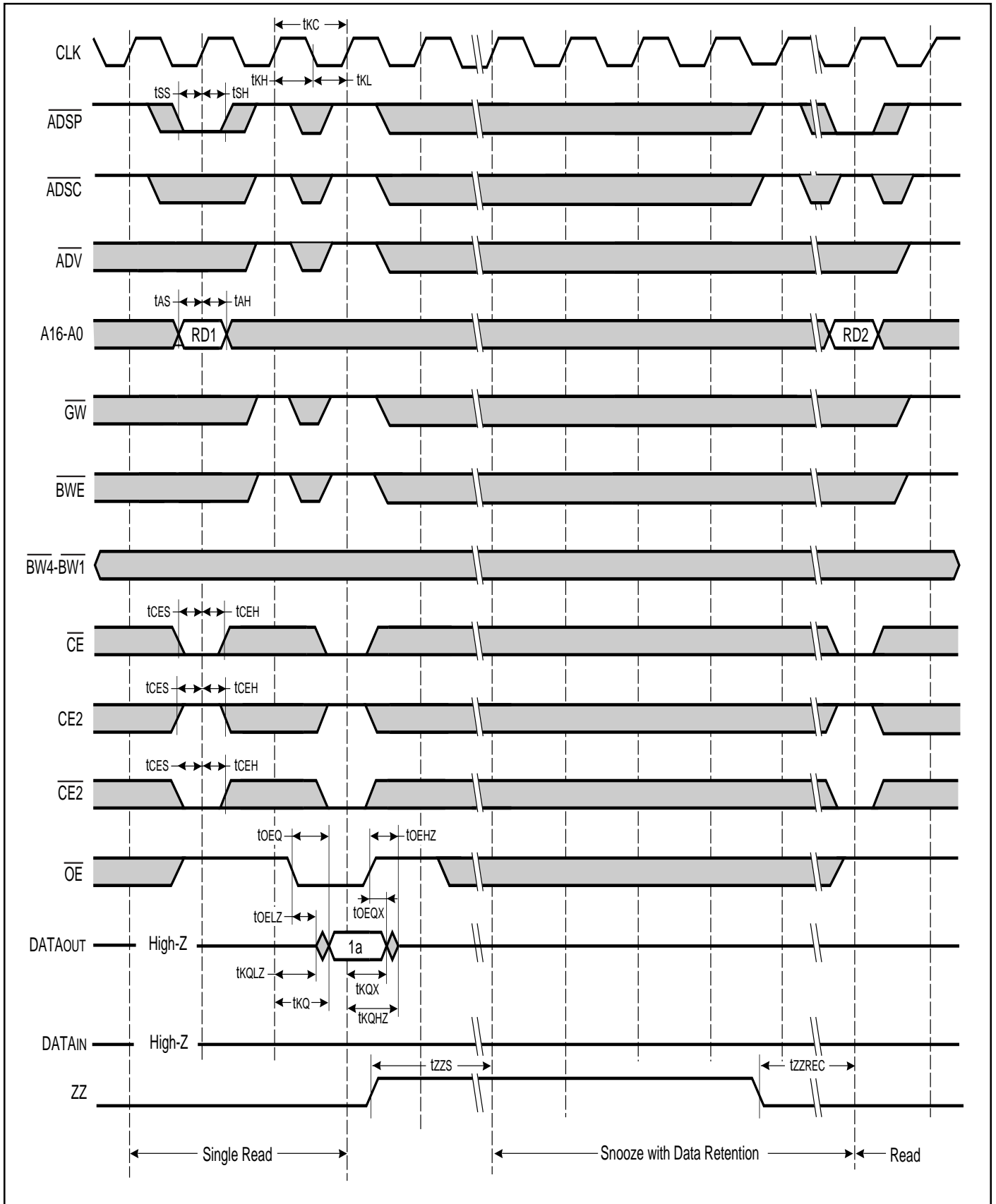
**SNOOZE AND RECOVERY CYCLE SWITCHING CHARACTERISTICS** (Over Operating Range)

Symbol	Parameter	-166		-150		-133		-117		-5		Unit
		Min.	Max.	Min.	Max.	Min.	Max.	Min.	Max.	Min.	Max.	
t <sub>KC</sub>	Cycle Time	6	—	6.7	—	7.5	—	8.5	—	10	—	ns
t <sub>KH</sub>	Clock High Time	2.4	—	2.6	—	2.8	—	3.4	—	4	—	ns
t <sub>KL</sub>	Clock Low Time	2.4	—	2.6	—	2.8	—	3.4	—	4	—	ns
t <sub>KQ</sub>	Clock Access Time	—	3.5	—	3.8	—	4	—	4	—	5	ns
t <sub>KQX</sub> <sup>(1)</sup>	Clock High to Output Invalid	1.5	—	1.5	—	1.5	—	2	—	2.5	—	ns
t <sub>KQLZ</sub> <sup>(1,2)</sup>	Clock High to Output Low-Z	0	—	0	—	0	—	0	—	0	—	ns
t <sub>KQHZ</sub> <sup>(1,2)</sup>	Clock High to Output High-Z	1.5	3.6	1.5	6.7	1.5	7.5	1.5	8.5	1.5	10	ns
t <sub>OEQ</sub>	Output Enable to Output Valid	—	3.5	—	3.5	—	3.9	—	4	—	5	ns
t <sub>OEQX</sub> <sup>(1)</sup>	Output Disable to Output Invalid	0	—	0	—	0	—	0	—	0	—	ns
t <sub>OEZ</sub> <sup>(1,2)</sup>	Output Enable to Output Low-Z	0	—	0	—	0	—	0	—	0	—	ns
t <sub>OEHZ</sub> <sup>(1,2)</sup>	Output Disable to Output High-Z	2	3.5	2	3.5	2	3.8	2	4	2	5	ns
t <sub>AS</sub>	Address Setup Time	1.5	—	1.5	—	1.5	—	1.5	—	1.5	—	ns
t <sub>SS</sub>	Address Status Setup Time	1.5	—	1.5	—	1.5	—	1.5	—	1.5	—	ns
t <sub>CES</sub>	Chip Enable Setup Time	1.5	—	1.5	—	1.5	—	1.5	—	1.5	—	ns
t <sub>AH</sub>	Address Hold Time	0.5	—	0.5	—	0.5	—	0.5	—	0.5	—	ns
t <sub>SH</sub>	Address Status Hold Time	0.5	—	0.5	—	0.5	—	0.5	—	0.5	—	ns
t <sub>CEH</sub>	Chip Enable Hold Time	0.5	—	0.5	—	0.5	—	0.5	—	0.5	—	ns
t <sub>ZZS</sub>	ZZ Standby	2	—	2	—	2	—	2	—	2	—	cyc
t <sub>ZZREC</sub>	ZZ Recovery	2	—	2	—	2	—	2	—	2	—	cyc

**Notes:**

1. Guaranteed but not 100% tested. This parameter is periodically sampled.
2. Tested with load in Figure 2.

**SNOOZE AND RECOVERY CYCLE TIMING**



**ORDERING INFORMATION****Commercial Range: 0°C to +70°C**

Speed	Order Part Number	Package
166 MHz	IS61SP12832-166TQ	TQFP
	IS61SP12832-166B	PBGA
150 MHz	IS61SP12832-150TQ	TQFP
	IS61SP12832-150B	PBGA
133 MHz	IS61SP12832-133TQ	TQFP
	IS61SP12832-133B	PBGA
117 MHz	IS61SP12832-117TQ	TQFP
	IS61SP12832-117B	PBGA
5 ns	IS61SP12832-5TQ	TQFP
	IS61SP12832-5B	PBGA

**Industrial Range: -40°C to +85°C**

Speed	Order Part Number	Package
150 MHz	IS61SP12832-150TQI	TQFP
133 MHz	IS61SP12832-133TQI	TQFP
117 MHz	IS61SP12832-117TQI	TQFP
5 ns	IS61SP12832-5TQI	TQFP

**ISSI®**

**Integrated Silicon Solution, Inc.**

2231 Lawson Lane  
 Santa Clara, CA 95054  
 Tel: 1-800-379-4774  
 Fax: (408) 588-0806  
 E-mail: sales@issi.com  
[www.issi.com](http://www.issi.com)