

1,024-BIT SERIAL ELECTRICALLY ERASABLE PROM

MARCH 2001

FEATURES

- State-of-the-art architecture
 - Non-volatile data storage
 - Low voltage operation: 3.0V (Vcc = 2.7V to 6.0V)
 - Full TTL compatible inputs and outputs
 - Auto increment for efficient data dump
- Low voltage read operation
 - Down to 2.7V
- Hardware and software write protection
 - Defaults to write-disabled state at power-up
 - Software instructions for write-enable/disable
- Advanced low voltage CMOS E²PROM technology
- Versatile, easy-to-use Interface
 - Self-timed programming cycle
 - Automatic erase-before-write
 - Programming status indicator
 - Word and chip erasable
 - Stop SK anytime for power savings
- Durable and reliable
 - 10-year data retention after 100K write cycles
 - 100,000 write cycles
 - Unlimited read cycles

OVERVIEW

The IS93C46-3 is a low cost 1,024-bit, non-volatile, serial E²PROM. It is fabricated using ISSI's advanced CMOS E²PROM technology. The IS93C46-3 provides efficient non-volatile read/write memory arranged as 64 registers of 16 bits each. Seven 9-bit instructions control the operation of the device, which includes read, write, and mode enable functions. The data out pin (DOUT) indicates the status of the device during in the self-timed non-volatile programming cycle.

The self-timed write cycle includes an automatic erase-before-write capability. To protect against inadvertent writes, the WRITE instruction is accepted only while the chip is in the write enabled state. Data is written in 16 bits per write instruction into the selected register. If Chip Select (CS) is brought HIGH after initiation of the write cycle, the Data Output (DOUT) pin will indicate the READY/BUSY status of the chip.

APPLICATIONS

The IS93C46-3 is ideal for high-volume applications requiring low power and low density storage. This device uses a low cost, space saving 8-pin package. Candidate applications include robotics, alarm devices, electronic locks, meters and instrumentation settings.

FUNCTIONAL BLOCK DIAGRAM

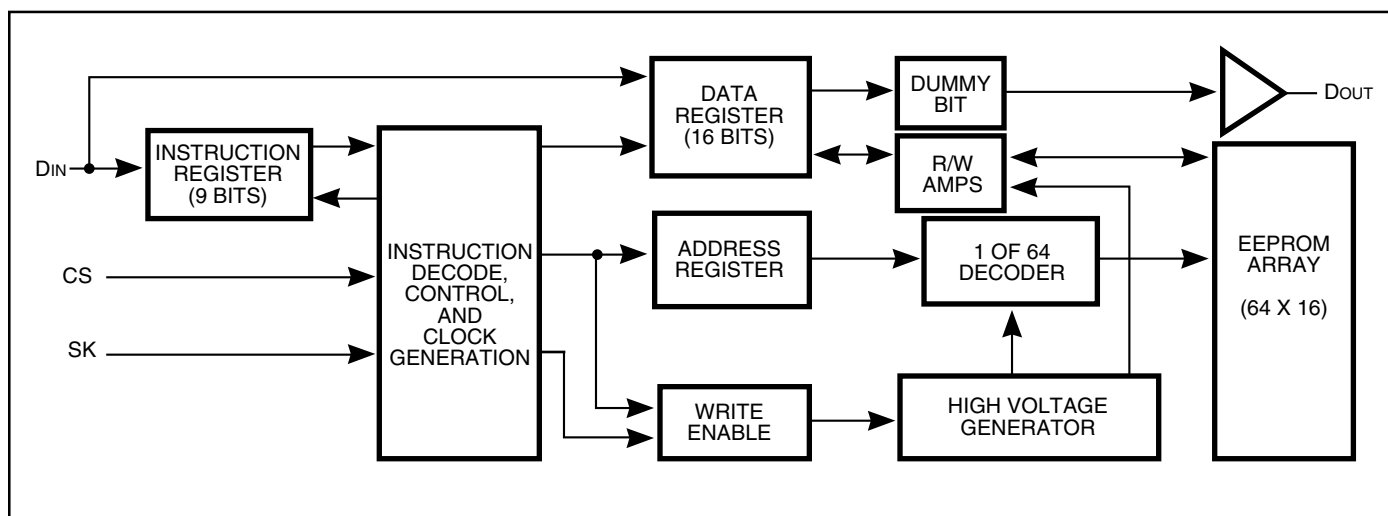

ISSI reserves the right to make changes to its products at any time without notice in order to improve design and supply the best possible product. We assume no responsibility for any errors which may appear in this publication. © Copyright 2001, Integrated Silicon Solution, Inc.

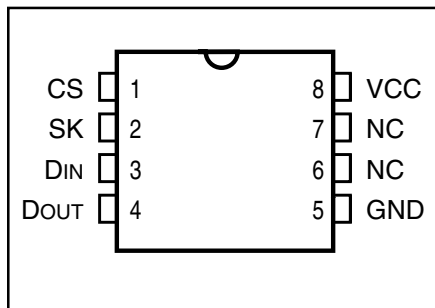
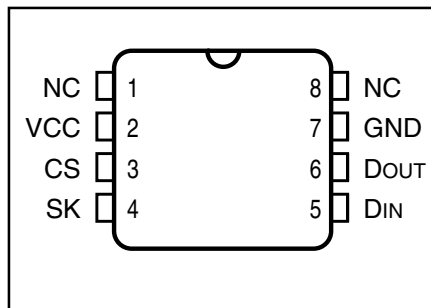
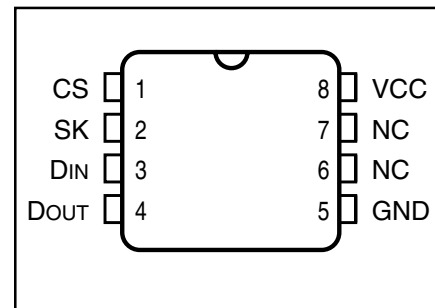
PIN CONFIGURATION**8-Pin DIP****PIN CONFIGURATION****8-Pin JEDEC Small Outline "G"****PIN CONFIGURATION****8-Pin JEDEC Small Outline "GR"****PIN DESCRIPTIONS**

CS	Chip Select
SK	Serial Data Clock
DIN	Serial Data Input
DOUT	Serial Data Output
NC	Not Connected
Vcc	Power
GND	Ground

ENDURANCE AND DATA RETENTION

The IS93C46-3 is designed for applications requiring up to 100,000 programming cycles (WRITE, WRALL, ERASE and ERAL). It provides 10 years of secure data retention, without power after the execution of 100,000 programming cycles.

DEVICE OPERATION

The IS93C46-3 is controlled by seven 9-bit instructions. Instructions are clocked in (serially) on the DIN pin. Each instruction begins with a logical "1" (the start bit). This is followed by the opcode (2 bits), the address field (6 bits), and data, if appropriate. The clock signal (SK) may be halted at any time and the IS93C46-3 will remain in its last state. This allows full static flexibility and maximum power conservation.

Read (READ)

The READ instruction is the only instruction that outputs serial data on the DOUT pin. After the read instruction and address have been decoded, data is transferred from the selected memory register into a 16-bit serial shift register. (Please note that one logical "0" bit precedes the actual 16-bit output data string.) The output on DOUT changes during the low-to-high transitions of SK (see Figure 3).

Low Voltage Read

The IS93C46-3 has been designed to ensure that data read operations are reliable in low voltage environments. The IS93C46-3 is guaranteed to provide accurate data during read operations with Vcc as low as 2.7V.

Auto Increment Read Operations

In the interest of memory transfer operation applications, the IS93C46-3 has been designed to output a continuous stream of memory content in response to a single read operation instruction. To utilize this function, the system asserts a read instruction specifying a start location address. Once the 16 bits of the addressed word have been clocked out, the data in consecutively higher address locations (the address "000000" is assumed as the address of "111111") is output. The address will wrap around continuously with CS HIGH until the chip select (CS) control pin is brought LOW. This allows for single instruction data dumps to be executed with a minimum of firmware overhead.

Write Enable (WEN)

The write enable (WEN) instruction must be executed before any device programming (WRITE, WRALL, ERASE, and ERAL) can be done. When Vcc is applied, this device

powers up in the write disabled state. The device then remains in a write disabled state until a WEN instruction is executed. Thereafter, the device remains enabled until a WDS instruction is executed or until Vcc is removed. (NOTE: Neither the WEN nor the WDS instruction has any effect on the READ instruction.) (See Figure 4.)

Write (WRITE)

The WRITE instruction includes 16 bits of data to be written into the specified register. After the last data bit has been applied to D_{IN}, and before the next rising edge of SK, CS must be brought LOW. The falling edge of CS initiates the self-timed programming cycle.

After a minimum wait of 250 ns (5V operation) from the falling edge of CS (t_{cs}), if CS is brought HIGH, D_{OUT} will indicate the READY/ $\overline{\text{BUSY}}$ status of the chip: logical “0” means programming is still in progress; logical “1” means the selected register has been written, and the part is ready for another instruction (see Figure 5). (NOTE: The combination of CS HIGH, D_{IN} HIGH and the rising edge of the SK clock, resets the READY/ $\overline{\text{BUSY}}$ flag. Therefore, it is important if you want to access the READY/ $\overline{\text{BUSY}}$ flag, not to reset it through this combination of control signals.) Before a WRITE instruction can be executed, the device must be write enabled (see WEN).

Write All (WRALL)

The write all (WRALL) instruction programs all registers with the data pattern specified in the instruction. While the WRALL instruction is being loaded, the address field

becomes a sequence of “Don’t Care” bits (see Figure 6). As with the WRITE instruction, if CS is brought HIGH after a minimum wait of 250 ns (t_{cs}), the D_{OUT} pin indicates the READY/ $\overline{\text{BUSY}}$ status of the chip (see Figure 6).

Write Disable (WDS)

The write disable (WDS) instruction disables all programming capabilities. This protects the entire part against accidental modification of data until a WEN instruction is executed. (When Vcc is applied, this part powers up in the write disabled state.) To protect data, a WDS instruction should be executed upon completion of each programming operation. (NOTE: Neither the WEN nor the WDS instruction has any effect on the READ instruction.) (See Figure 7.)

Erase Register (ERASE)

After the erase instruction is entered, CS must be brought LOW. The falling edge of CS initiates the self-timed internal programming cycle. Bringing CS HIGH after a minimum of t_{cs}, will cause D_{OUT} to indicate the READY/ $\overline{\text{BUSY}}$ status of the chip: a logical “0” indicates programming is still in progress; a logical “1” indicates the erase cycle is complete and the part is ready for another instruction (see Figure 8).

Erase All (ERALL)

Full chip erase is provided for ease of programming. Erasing the entire chip involves setting all bits in the entire memory array to a logical “1” (see Figure 9).

INSTRUCTION SET

Instruction	Start Bit	OP Code	Address	Input Data
READ	1	10	(A5-A0)	
WEN (Write Enable)	1	00	11XXXX	
WRITE	1	01	(A5-A0)	D15-D0 ⁽¹⁾
WRALL (Write All Registers)	1	00	01XXXX	D15-D0 ⁽¹⁾
WDS (Write Disable)	1	00	00XXXX	
ERASE	1	11	(A5-A0)	
ERALL (Erase All Registers)	1	00	10XXXX	

Note: 1. If input data is not 16 bits exactly, the last 16 bits will be taken as input data (a word).

ABSOLUTE MAXIMUM RATINGS⁽¹⁾

Symbol	Parameter	Value	Unit
V _{GND}	Voltage with Respect to GND	-0.3 to +6.5	V
T _{BIAS}	Temperature Under Bias (IS93C46-3)	0 to +70	°C
T _{BIAS}	Temperature Under Bias (IS93C46-3I)	-40 to +85	°C
T _{STG}	Storage Temperature	-65 to +125	°C

Notes:

1. Stress greater than those listed under ABSOLUTE MAXIMUM RATINGS may cause permanent damage to the device. This is a stress rating only and functional operation of the device at these or any other conditions above those indicated in the operational sections of this specification is not implied. Exposure to absolute maximum rating conditions for extended periods may affect reliability.

OPERATING RANGE

Range	Ambient Temperature	V _{CC}
Commercial	0°C to +70°C	2.7V to 6.0V
Industrial	-40°C to +85°C	2.7V to 6.0V

CAPACITANCE

Symbol	Parameter	Conditions	Max.	Unit
C _{IN}	Input Capacitance	V _{IN} = 0V	5	pF
C _{OUT}	Output Capacitance	V _{OUT} = 0V	5	pF

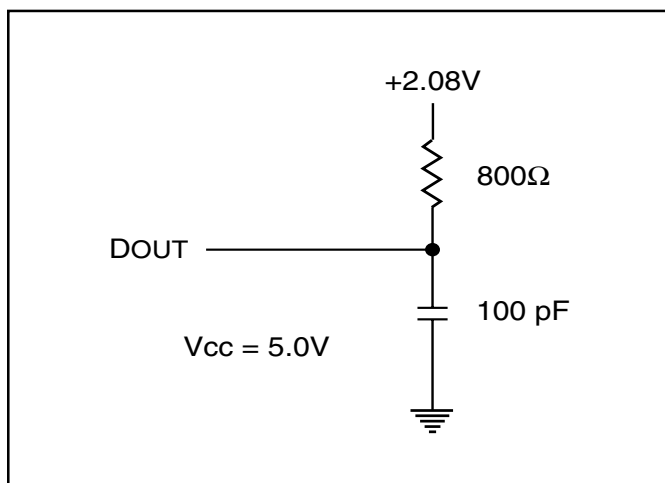
FIGURE 1. AC TEST CONDITIONS

DC ELECTRICAL CHARACTERISTICS

T_A = 0°C to +70°C for IS93C46-3 and -40°C to +85°C for IS93C46-3I.

Symbol	Parameter	Test Conditions	V _{CC}	Min.	Max.	Unit
V _{OL}	Output LOW Voltage	I _{OL} = 10 μA CMOS	2.7V to 3.3V	—	0.2	V
V _{OL1}	Output LOW Voltage	I _{OL} = 2.1 mA TTL	4.5V to 5.5V	—	0.4	V
V _{OH}	Output HIGH Voltage	I _{OH} = -10 μA CMOS	2.7V to 3.3V	V _{CC} - 0.2	—	V
V _{OH1}	Output HIGH Voltage	I _{OH} = -400 μA TTL	4.5V to 5.5V	2.4	—	V
V _{IH}	Input HIGH Voltage		2.7V to 3.3V 4.5V to 5.5V	2.4 2	V _{CC} V _{CC}	V
V _{IL}	Input LOW Voltage		2.7V to 3.3V 4.5V to 5.5V	-0.1 -0.1	0.6 0.8	V
I _{LI}	Input Leakage	V _{IN} = 0V to V _{CC} (CS, SK, D _{IN})		1	1	μA
I _{LO}	Output Leakage	V _{OUT} = 0V to V _{CC} , CS = 0V		1	1	μA

POWER SUPPLY CHARACTERISTICS

T_A = 0°C to +70°C for IS93C46-3 and -40°C to +85°C for IS93C46-3I.

Symbol	Parameter	Test Conditions	V _{CC}	IS93C46-3			IS93C46-3I			Unit
				Min.	Typ.	Max.	Min.	Typ.	Max.	
I _{CC}	V _{CC} Operating Supply Current	CS = V _{IH} , SK = 500 KHz CMOS Input Levels	2.7V to 3.3V	—	0.5	2	—	0.5	2	mA
I _{CC}	V _{CC} Operating Supply Current	CS = V _{IH} , SK = 1 MHz CMOS Input Levels	4.5V to 5.5V	—	4	6	—	4	6	mA
I _{SB}	Standby Current	CS = D _{IN} = SK = 0V	2.7V to 3.3V 4.5V to 5.5V	—	2	10	—	2	10	μA

AC ELECTRICAL CHARACTERISTICS

TA = 0°C to +70°C for IS93C46-3 and -40°C to +85°C for IS93C46-3I.

Symbol	Parameter	Test Conditions	Vcc	IS93C46-3		IS93C46-3I		Unit
				Min.	Max.	Min.	Max.	
fSK	SK Clock Frequency		2.7V to 6.0V	0	500	0	500	KHz
			4.5V to 6.0V	0	1	0	1	MHz
tSKH	SK HIGH Time		2.7V to 6.0V	500	—	500	—	ns
			4.5V to 6.0V	250	—	250	—	
tSKL	SK LOW Time		2.7V to 6.0V	1	—	1	—	µs
			4.5V to 6.0V	250	—	250	—	ns
tCS	Minimum CS LOW Time		2.7V to 6.0V	500	—	500	—	ns
			4.5V to 6.0V	250	—	250	—	
tCSS	CS Setup Time	Relative to SK	2.7V to 6.0V	100	—	100	—	ns
			4.5V to 6.0V	50	—	50	—	ns
tDIS	DIN Setup Time	Relative to SK	2.7V to 6.0V	200	—	200	—	ns
			4.5V to 6.0V	100	—	100	—	ns
tCSH	CS Hold Time	Relative to SK	2.7V to 6.0V	0	—	0	—	ns
			4.5V to 6.0V	0	—	0	—	
tDIH	DIN Hold Time	Relative to SK	2.7V to 6.0V	400	—	400	—	ns
			4.5V to 6.0V	100	—	100	—	
tPD1	Output Delay to "1"	AC Test	2.7V to 6.0V	—	500	—	500	ns
			4.5V to 6.0V	—	500	—	500	
tPD0	Output Delay to "0"	AC Test	2.7V to 6.0V	—	500	—	500	ns
			4.5V to 6.0V	—	500	—	500	
tSV	CS to Status Valid	AC Test, CL = 100 pF	2.7V to 6.0V	—	500	—	500	ns
			4.5V to 6.0V	—	500	—	500	
tDF	CS to DOUT in 3-state	CS = VIL	2.7V to 6.0V	—	200	—	200	ns
			4.5V to 6.0V	—	100	—	100	
tWP	Write Cycle Time		2.7V to 6.0V	—	10	—	10	ms
			4.5V to 6.0V	—	10	—	10	

AC WAVEFORMS

FIGURE 2. SYNCHRONOUS DATA TIMING

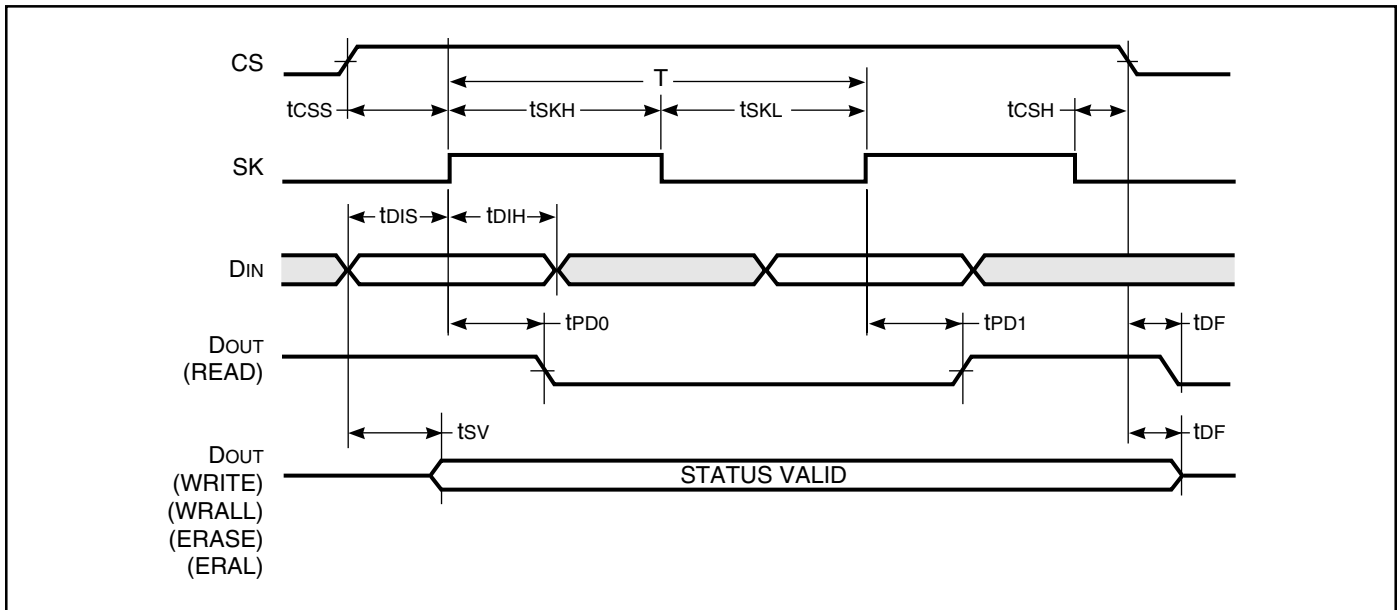

FIGURE 3. READ CYCLE TIMING

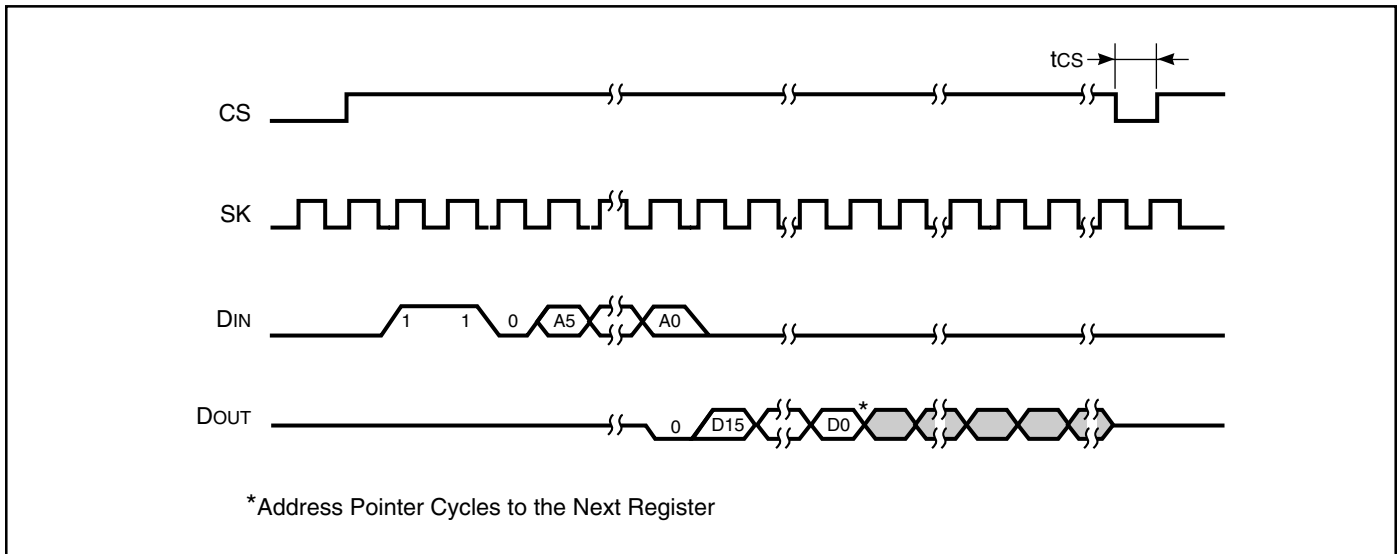

FIGURE 4. SYNCHRONOUS DATA TIMING

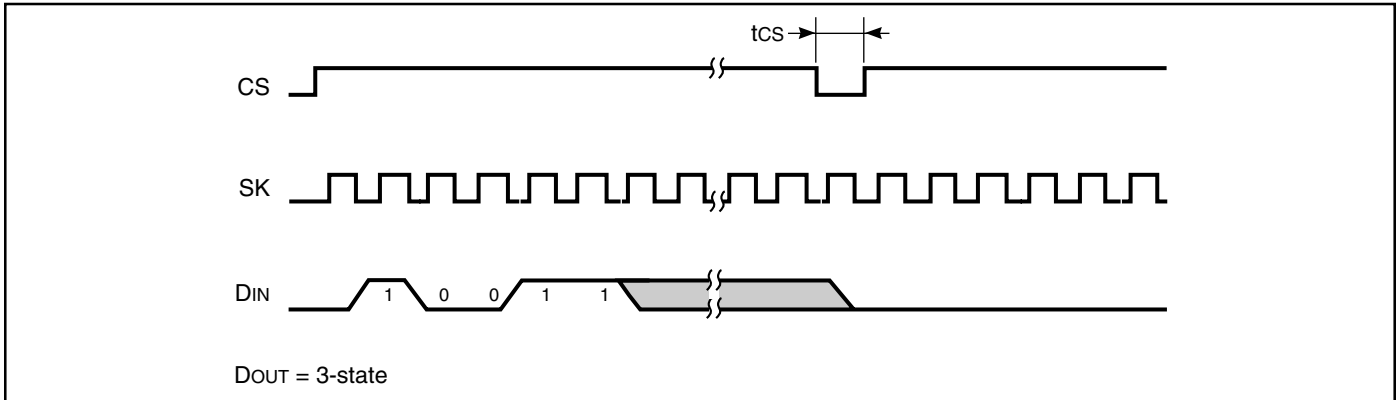

FIGURE 5. WRITE (WRITE) CYCLE TIMING

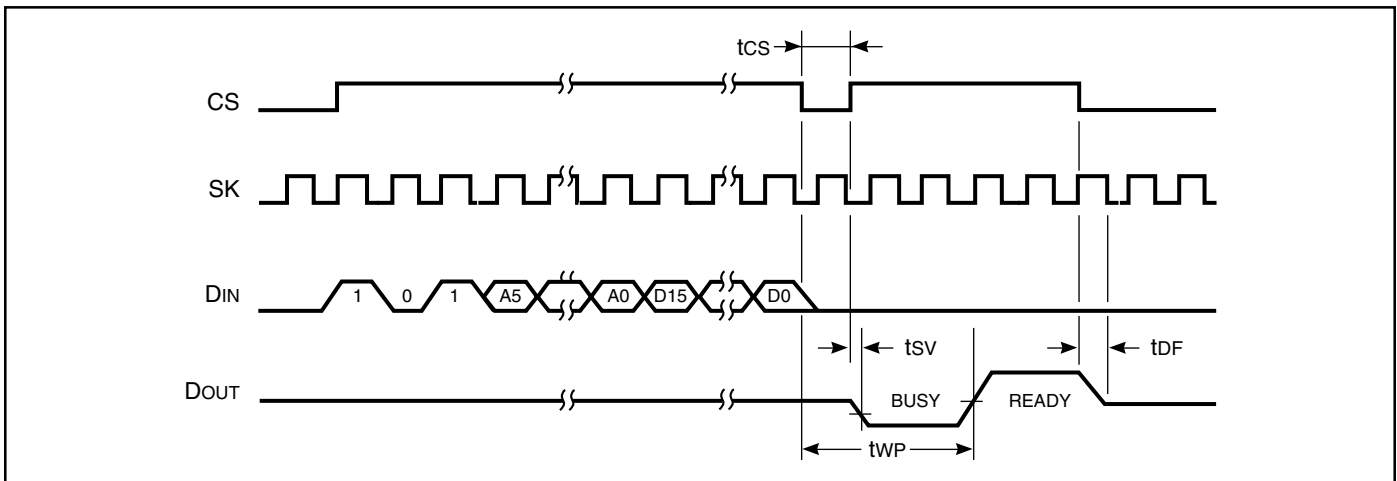

FIGURE 6. WRITE ALL (WRALL) TIMING

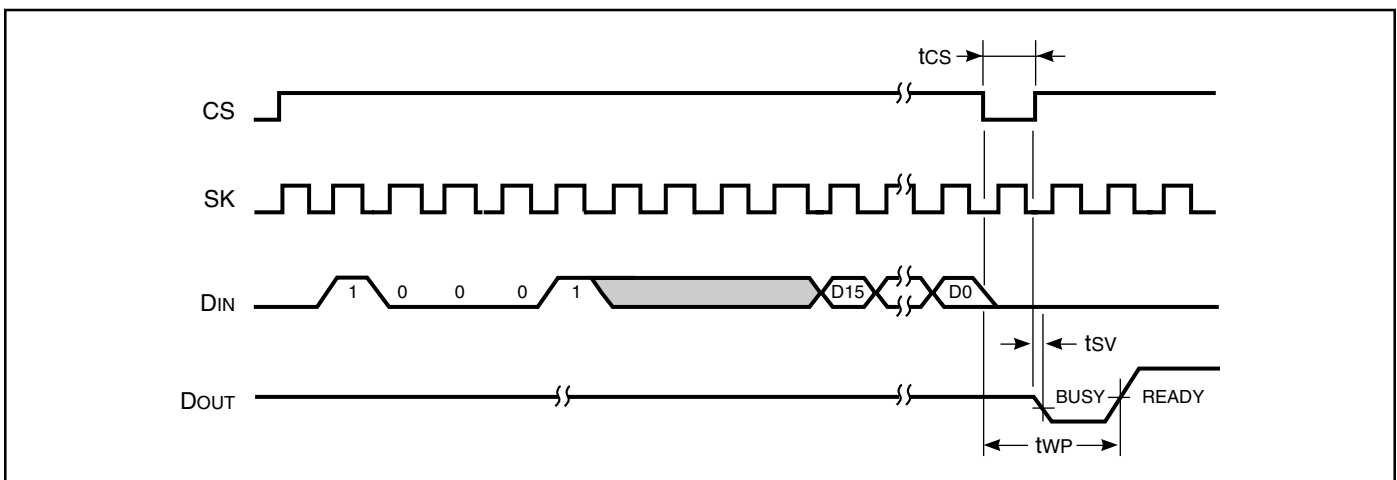

FIGURE 7. WRITE DISABLE (WDS) CYCLE TIMING

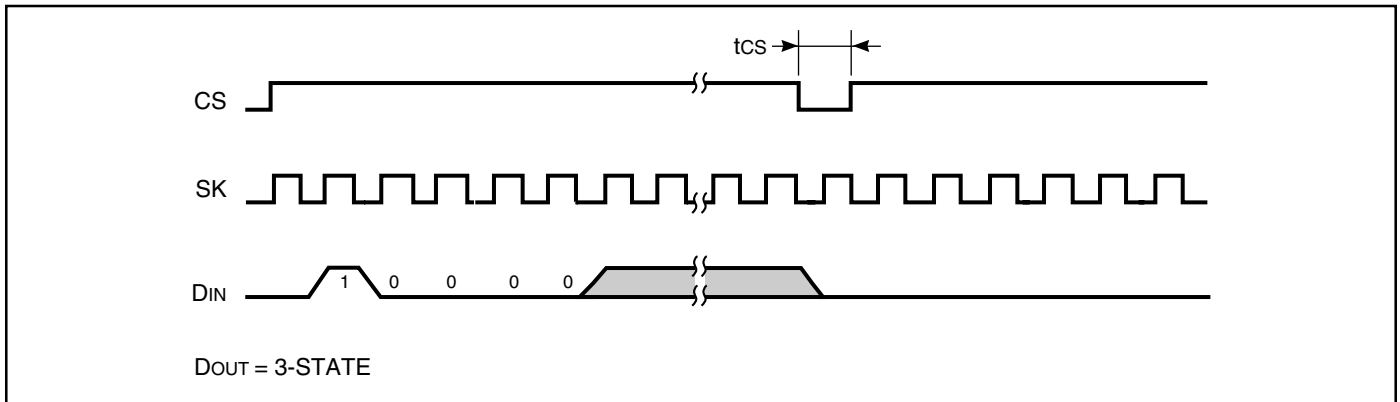

FIGURE 8. ERASE (REGISTER ERASE) CYCLE TIMING

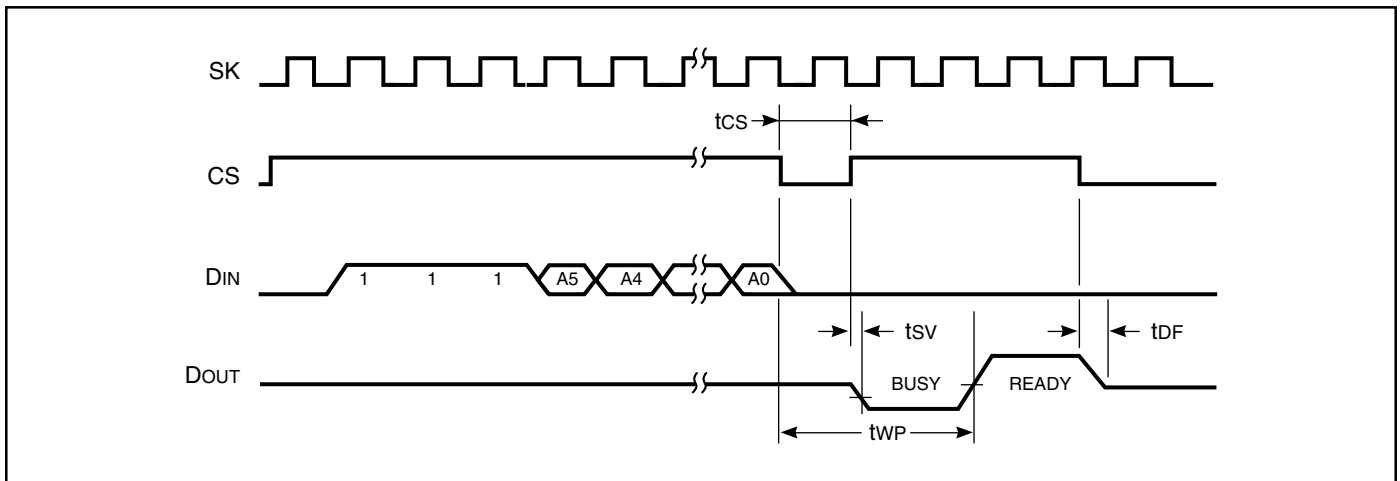
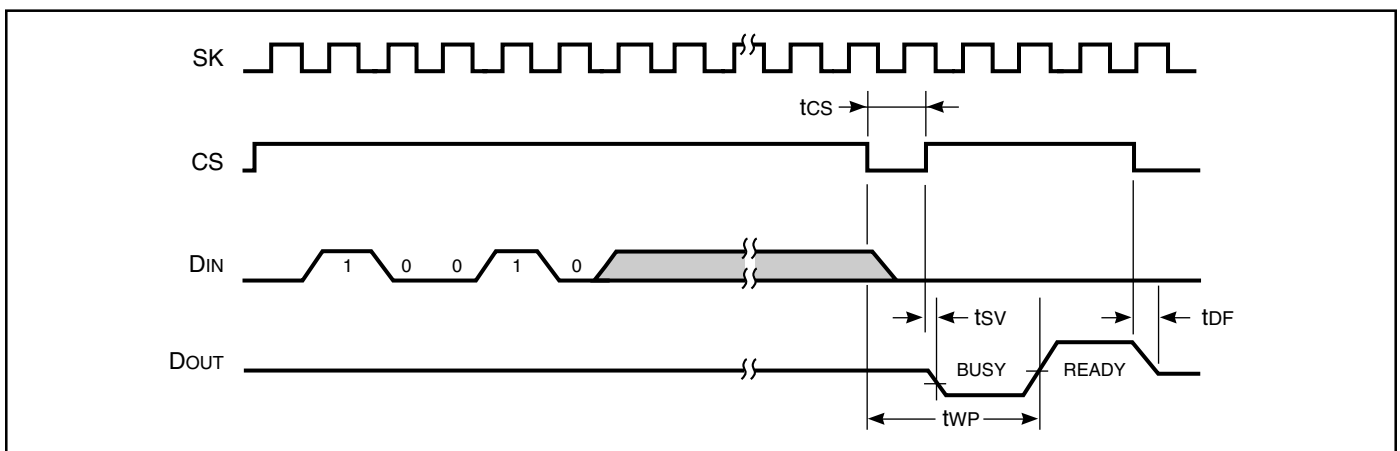

FIGURE 9. ERASE ALL (ERAL) CYCLE TIMING



Note for Figures 8 and 9:

After the completion of the instruction (DOUT is in READY status) then it may perform another instruction. If device is in $\overline{\text{BUSY}}$ status (DOUT indicates $\overline{\text{BUSY}}$ status) then performs another instruction would cause device malfunction.

ORDERING INFORMATION**Commercial Range: 0°C to +70°C**

Speed (KHz)	Order Part No.	Package
500	IS93C46-3P	300-mil Plastic DIP
500	IS93C46-3G	Small Outline (JEDEC)
500	IS93C46-3GR	Small Outline (JEDEC)

ORDERING INFORMATION**Industrial Range: -40°C to +85°C**

Speed (MHz)	Order Part No.	Package
1	IS93C46-3PI	300-mil Plastic DIP
1	IS93C46-3GI	Small Outline (JEDEC)
1	IS93C46-3GRI	Small Outline (JEDEC)

ISSI®

Integrated Silicon Solution, Inc.

2231 Lawson Lane
 Santa Clara, CA 95054
 Tel: 1-800-379-4774
 Fax: (408) 588-0806
 E-mail: sales@issi.com
www.issi.com