

Introduction

The ISL62386 evaluation boards demonstrates the performance of the ISL62386 quad-output voltage controller. The ISL62386 includes two pulse-width modulated (PWM) controllers featuring Intersil's patented R³ technology and two linear regulators, LDO5 and LDO3. The PWM controllers are adjustable from 0.6V to 5.5V, and the LDOs generate fixed 5V and 3.3V outputs respectively.

The evaluation board includes independent Enable switches, one LED Power-Good indicator and numerous test points. Included with each switching channel is an on-board dynamic load generator for evaluating the transient-load response. There are two variations of the evaluation boards to provide flexible evaluation options. Table 1 shows a brief description of the evaluation boards.

TABLE 1. EVALUATION BOARD DESCRIPTION

EVALUATION BOARD	CHANNEL-1	CHANNEL-2	OCP
ISL62386LOEVAL1Z	3.3V/8A	5V/8A	~10A
ISL62386HIEVAL1Z	1.05V/15A	1.5V/15A	~20A

What's Needed

The following materials will be needed to perform testing:

- Adjustable +25V, 30A Power Supply
- +12V, 100mA Power Supply
- Precision digital multi-meter
- 4 Electronic Loads
- 4-Channel Oscilloscope

Enable Control

The evaluation board provides flexible control logic to enable or disable the outputs, and to program the two PWM channels' start-up sequence. Table 2 is the enable controller truth table. For start-up timing sequence, please refer to the datasheet waveforms.

TABLE 2. ENABLE TRUTH TABLE

EN1	EN2	START-UP SEQUENCE
Low	Low	Both Channel outputs OFF simultaneously
Low	Float	Both Channel outputs OFF simultaneously
Float	Low	Both Channel outputs OFF simultaneously
Float	Float	Both Channel outputs OFF simultaneously
Low	High	Channel-1 OFF, Channel-2 ON
High	Low	Channel-1 ON, Channel-2 OFF
High	High	Both Channel outputs ON simultaneously

TABLE 2. ENABLE TRUTH TABLE (Continued)

EN1	EN2	START-UP SEQUENCE
Float	High	Channel-1 enabled after Channel-2 is in regulation
High	Float	Channel-2 enabled after Channel-1 is in regulation

Resistor Current Sense Configuration

The evaluation board is pre-configured with inductor DCR current sense. For more precise overcurrent protection, it also provides the option of resistor current sense. Figure 1 shows the configuration for resistor current sense.

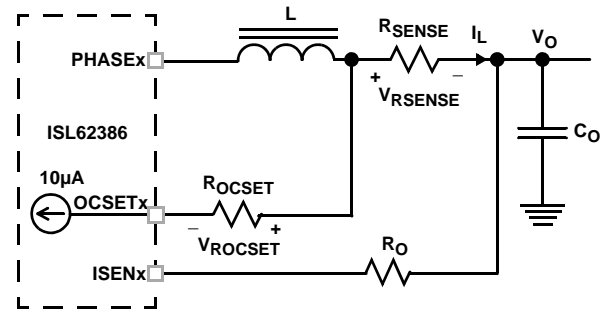
FIGURE 1. RESISTOR CURRENT SENSE CIRCUIT

For Channel-1, the ISL62386 monitors the OCSET1 pin and the ISEN1 pin voltages. Once the OCSET1 pin voltage is higher than the ISEN1 pin voltage for more than 10µs, the ISL62386 declares an overcurrent fault. For a chosen overcurrent set point I_{OC} and current sense resistor R_{SENSE}, the value of R_{OCSET} is determined by Equation 1

$$R_{OCSET} = \frac{I_{OC} \cdot R_{SENSE}}{10\mu A} \quad (\text{EQ. 1})$$

Where:

- R_{OCSET} (Ω) is the resistor used to program the overcurrent setpoint
- I_{OC} is the output current threshold that will activate the OCP circuit
- R_{SENSE} is current sense resistor (R₃ for Channel-1 and R₂₅ for Channel-2)

Take Channel-1 as an example, once the value of R_{OCSET} is calculated, follow the following procedure to configure the resistor current sense circuit:

- Step 1:** Open the "DCR SENSE" solder bridge and connect the "RESISTOR SENSE" solder bridge on the PCB bottom layer;
- Step 2:** Remove R₇ (R₂₂ for Channel-2);
- Step 3:** Replace R₃ (R₂₅ for Channel-2) with R_{SENSE};
- Step 4:** Replace C₆ (C₂₅ for Channel-2) with R_{OCSET};
- Step 5:** Replace R₁₉ (R₁₈ for Channel-2) with R_{OCSET}.

Application Note 1456

Dynamic Load Generator

The evaluation board provides each PWM channel an on-board dynamic load generator for evaluating the transient-load response, which are controlled by SW1 and SW2 respectively. The dynamic load generator applies a

300µs pulse load across V_{OUT} and GND. The transient load slew-rate can be trimmed by adjusting the resistors R₃₄, R₄₀ for the rising edge, and R₃₈, R₃₉ for the falling edge. +12V power supply is needed to power the dynamic load generator.

Connections and Test Points

The following table describes the function and operation of the evaluation boards.

NUMBER	NAME	FUNCTION/OPERATION
INTERFACES AND CONNECTIONS		
TP3	VBAT	V _{IN} positive power input
TP4	GND	V _{IN} return power input
TP1	VOUT1	Channel-1 positive power output
TP2	GND	Channel-1 return power output
TP11	VOUT2	Channel-2 positive power output
TP12	GND	Channel-2 return power output
TP20	+12V	+12V positive power input, used for the power supply of the on-board dynamic-load generator
TP19	GND	+12V return power input
TEST POINTS		
J1	PHASE2	Scope-probe socket for measuring Channel-2 phase node
J3	PHASE1	Scope-probe socket for measuring Channel-1 phase node
J2	VOUT1	Scope-probe socket for measuring Channel-1 output
J5	VOUT2	Scope-probe socket for measuring Channel-2 output
J4	FLOAT_FCCM	Remove the jumper will float the FCCM pin
J6	FLOAT_EN1	Remove the jumper will float the EN1 pin
J7	FLOAT_EN2	Remove the jumper will float the EN2 pin
TP17	EN1	Test point of EN1 pin
TP8	EN2	Test point of EN2 pin
TP9	LDO3EN	Test point of LDO3EN pin
TP10	FCCM	Test point of FCCM pin
POWER-GOOD INDICATOR		
TP13	PGOOD	Test point of PGOOD pin
D2		LED Power-Good indicator. Green when both Channel-1 and Channel-2 are in regulation.
LINEAR REGULATORS		
TP14	LDO5	LDO5 linear regulator positive power output
TP15	GND	LDO5 linear regulator return power output
TP6	LDO3	LDO3 linear regulator positive power output
TP7	GND	LDO3 linear regulator return power output
SWITCHES		
SW1		ON/OFF control of Channel-2 dynamic-load generator. Toggle to ON will enable the dynamic load, toggle to OFF will disable the transient load
SW2		ON/OFF control of Channel-1 dynamic-load generator. Toggle to ON will enable the dynamic load, toggle OFF will disable the transient load
U2		High: High level for EN1, EN2, LDO3EN and FCCM, respectively Low: Low level for EN1, EN2, LDO3EN and FCCM, respectively

Test Set-up

Figure 2 shows a typical test configuration.

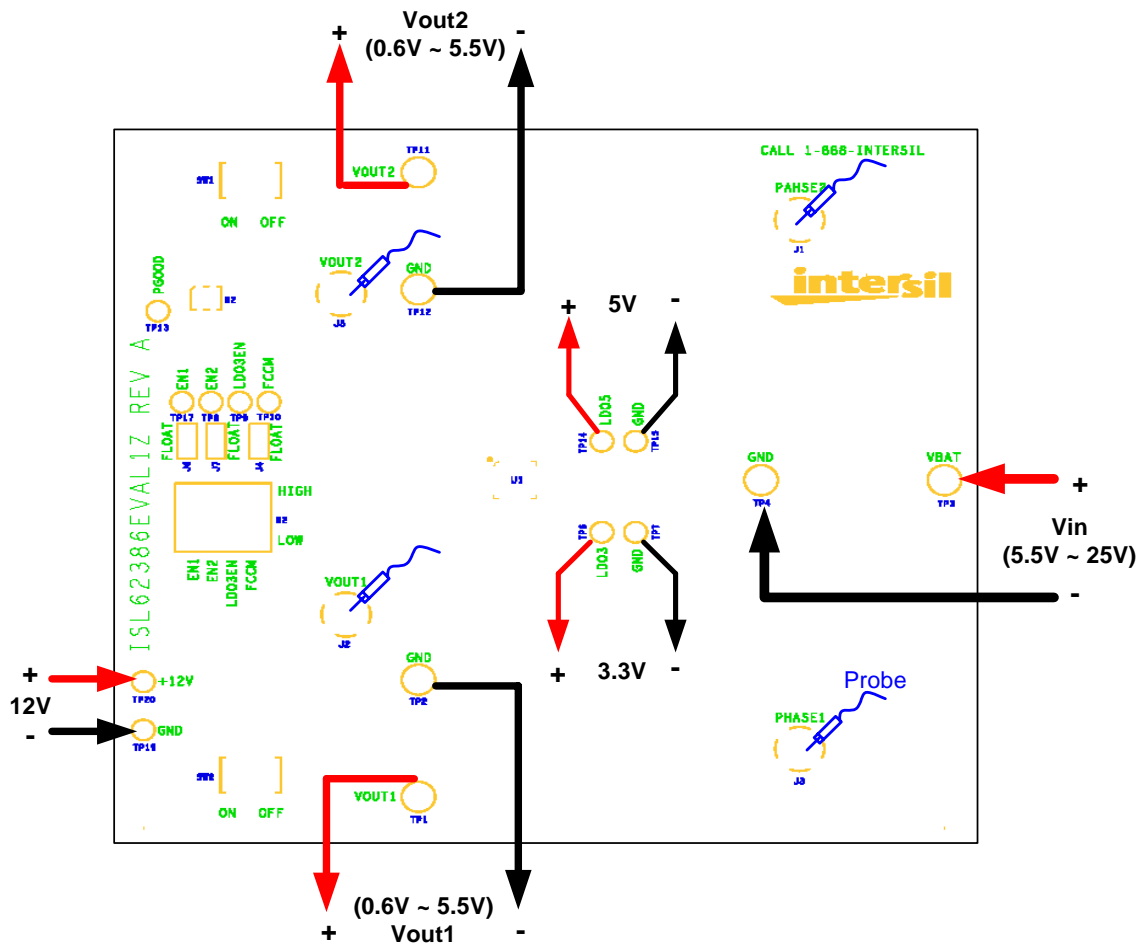

FIGURE 2. TYPICAL TEST CONFIGURATION

Application Note 1456

ISL62386LOEVAL1Z Evaluation Board Bill of Materials

NO.	REFERENCE DESIGNATOR	QTY	VALUE	VOLTAGE/ POWER	TOL. (%)	MANUFACTURER	DESCRIPTION
1	C6, C25	2	0.022 μ F	25V	10	GENERIC	SM_CAP_0603, 0.022 μ F, 25V, 10%, X7R, ROHS
2	C8, C9	2	0.01 μ F	16V	10	GENERIC	SM_CAP_0603, 0.01 μ F, 16V, 10%, X7R, ROHS
3	C17, C19	2	0.22 μ F	16V	10	GENERIC	SM_CAP_0603, 0.22 μ F, 16V, 10%, X7R, ROHS
4	C13, C15, C22, C23	4	10 μ F	25V	10	GENERIC	SM_CAP_1206, 10 μ F, 25V, 10%, X7R, ROHS
5	C12, C14	2	1200pF	16V	10	GENERIC	SM_CAP_0603, 1200PF, 16V, 10%, X7R, ROHS
6	C10, C16, C18	3	1 μ F	16V	10	GENERIC	SM_CAP_0603, 1 μ F, 16V, 10%, X7R, ROHS
7	C30	1	1 μ F	25V	10	GENERIC	SM_CAP_0805, 1 μ F, 25V, 10%, X7R, ROHS
8	C11, C24	2	1 μ F	25V	10	GENERIC	SM_CAP_1206, 1 μ F, 25V, 10%, X7R, ROHS
9	C1, C2, C20, C21, C28, C29	6	4.7 μ F	10V	10	GENERIC	SM_CAP_0805, 4.7 μ F, 10V, 10%, X7R, ROHS
10	C31, C32	2	10 μ F	16V	10	GENERIC	SM_CAP_0805, 10 μ F, 16V, 10%, X5R, ROHS
11	C3	1	56 μ F	25V	20	SANYO-OSCON	RADIAL_POLCAP_RADIAL, 25SP56M, 56 μ F, 25V, 20%, CASE-CC
12	C4, C26	2	330 μ F	6.3V	10	SANYO-POSCAP	SM_POLCAP_SMD, 6TPF330M9L, 330UF, 6.3V, 10%, CAP_7343
13	R12, R15	2	750	1/10W	1	GENERIC	SM_RES_0603, 750, 1/10W, 1%, TF, ROHS
14	R11	1	10k	1/10W	1	GENERIC	SM_RES_0603, 10k, 1/10W, 1%, TF, ROHS
15	R14	1	9.09k	1/10W	1	GENERIC	SM_RES_0603, 9.09k, 1/10W, 1%, TF, ROHS
16	R13	1	68.1k	1/10W	1	GENERIC	SM_RES_0603, 68.1k, 1/10W, 1%, TF, ROHS
17	R7, R18, R19, R22	4	15.8k	1/10W	1	GENERIC	SM_RES_0603, 15.8k, 1/10W, 1%, TF, ROHS
18	R8	1	19.6k	1/10W	1	GENERIC	SM_RES_0603, 19.6k, 1/10W, 1%, TF, ROHS
19	R9	1	24.3k	1/10W	1	GENERIC	SM_RES_0603, 24.3k, 1/10W, 1%, TF, ROHS
20	R16	1	45.3k	1/10W	1	GENERIC	SM_RES_0603, 45.3k, 1/10W, 1%, TF, ROHS
21	R20, R33, R39	3	1k	1/10W	1	GENERIC	SM_RES_0603, 1k, 1/10W, 1%, TF, ROHS
22	R38	1	1.58k	1/10W	1	GENERIC	SM_RES_0603, 1.58k, 1/10W, 1%, TF, ROHS
23	R17, R32	2	48.7k	1/10W	1	GENERIC	SM_RES_0603, 48.7k, 1/10W, 1%, TF, ROHS
24	R1, R2	2	0	1/10W	1	GENERIC	SM_RES_0603, 0, 1/10W, 1%, TF, ROHS
25	R34, R40	2	200	1/10W	1	GENERIC	SM_RES_0603, 200, 1/10W, 1%, TF, ROHS
26	R27	1	499	1/10W	1	GENERIC	SM_RES_0603, 499, 1/10W, 1%, TF, ROHS
27	R21, R23, R24, R28, R31	5	100k	1/10W	1	GENERIC	SM_RES_0603, 100k, 1/10W, 1%, TF, ROHS
28	R35	1	0.7	1W	1	GENERIC	SM_RES_2512, 0.7, 1W, 1%, TF, ROHS
29	R37	1	0.5	1W	1	GENERIC	SM_RES_2512, 0.5, 1W, 1%, TF, ROHS
30	D2	1	SSL_LXA3025IGC			LUMEX	SSL_LXA3025IGC_SMD-SSL-LXA3025IGC, LED_3x2_5MM
31	D3, D4	2	BAT54S			DIODES	SM_SCHOTTKY_BAT54S-BAT54S, SOT23
32	Q2, Q4	2	IRF7821PBF			IR	30V 13.6A N-Channel HEXFET Power MOSFET (Pb-free)
33	Q3, Q5	2	IRF7832PBF			IR	30V 20A N-Channel HEXFET Power MOSFET (Pb-free)
34	Q6, Q10, Q12	3	2N7002-7-F			FAIRCHILD	2N7002_SOT23-2N7002-7-F, SOT23

Application Note 1456

ISL62386LOEVAL1Z Evaluation Board Bill of Materials (Continued)

NO.	REFERENCE DESIGNATOR	QTY	VALUE	VOLTAGE/ POWER	TOL. (%)	MANUFACTURER	DESCRIPTION
35	Q11, Q13	2	SUD50N03-07			VISHAY	SUD50N03_07_TO252-SUD50N03-07, TO-252AA
36	SW1, SW2	2	GT11MSCBE-T			C&K	GT11MSCKE_SMT-GT11MSCBE-T, GT13MSCKE
37	TP6, TP7, TP8, TP9, TP10, TP13, TP14, TP15, TP17, TP18, TP19, TP20	12	5002			KEYSTONE	TEST_POINT_THOLE-5002,MTP500X
38	TP1, TP2, TP3, TP4, TP11, TP12	6	1514-2			KEYSTONE	TEST_POINT_THOLE-1514-2,TP-150C100P
39	J1, J2, J3, J5	4	131-5031-00			TEKTRONIX	SCOPE_PROBE_5P_CONN-131-5031-00, TEK131-5031-00
40	J4, J6, J7	3	68000-236			FCI	CONN2_DIP2-68000-236, CONN2
41	U2	1	78B04S			GRAYHILL	DIP_SW4_SPST_DIP-78B04S, DIP8-SW4
42	U1	1	ISL62386HRTZ			INTERSIL	ISL62386HRTZ, 32 LD 5x5 TQFN
43	U3, U4	2	HIP2100IBZ			INTERSIL	HIP2100_SOIC-HIP2100IBZ,SOIC8_150_50
44	L1, L2	2	4.7μH		20%	VISHAY	VISHAY_IHLP_5050CE_SMT-20%-IHLP- 5050CE-01-4R7M, 4.7μH, 24A, 20%, VISHAY_IHLP-5050CE
45	R3, R25	2	Wire			GENERIC	Wire short
46	DCR SENSE	4	Wire			GENERIC	Wire short
47	Jumper Connector	3	SPC02SYAN			SULLINS	Connector Jumper for J4, J6, J7
48		1	PCB			TBD	ISL62386EVAL1Z REVA PCB
49		1	Label			TBD	LABEL, FOR SERIAL NUMBER AND BOM REV #
50	C5, C27, C33, C34, C35, C36	6	No-pop				
51	R26, R36, R41	3	No-pop				
52	Q7, Q8, Q9, Q14	4	No-pop				

Application Note 1456

ISL62386HIEVAL1Z Evaluation Board Bill of Materials

The ISL62386HIEVAL1Z evaluation board use the same PCB and schematic as the ISL62386LOEVAL1Z evaluation boards but different bill of materials (BOM). The following table shows the BOM difference of ISL62386HIEVAL1Z in comparison with ISL62386LOEVAL1Z.

NO.	REFERENCE DESIGNATOR	QTY	VALUE	VOLTAGE /POWER	TOL. (%)	MANUFACTURER	DESCRIPTION
1	Q8, Q14	2	IRF7821PBF			IR	30V 13.6A N-Channel HEXFET Power MOSFET (Pb-free)
2	Q7, Q9	2	IRF7832PBF			IR	30V 20A N-Channel HEXFET Power MOSFET (Pb-free)
3	R8	1	14k	1/10W	1	GENERIC	SM_RES_0603, 14k, 1/10W, 1%, TF, ROHS
4	R9	1	17.4k	1/10W	1	GENERIC	SM_RES_0603, 17.4k, 1/10W, 1%, TF, ROHS
5	R11	1	23.2k	1/10W	1	GENERIC	SM_RES_0603, 23.2k, 1/10W, 1%, TF, ROHS
6	R16	1	17.8k	1/10W	1	GENERIC	SM_RES_0603, 17.8k, 1/10W, 1%, TF, ROHS
7	R13	1	15k	1/10W	1	GENERIC	SM_RES_0603, 15k, 1/10W, 1%, TF, ROHS
8	R14	1	10k	1/10W	1	GENERIC	SM_RES_0603, 10k, 1/10W, 1%, TF, ROHS
9	R7, R18, R19, R22	4	16.2k	1/10W	1	GENERIC	SM_RES_0603, 16.2k, 1/10W, 1%, TF, ROHS
10	R35	1	0.2	1W	1	GENERIC	SM_RES_2512, 0.2, 1W, 1%, TF, ROHS
11	R37	1	0.1	1W	1	GENERIC	SM_RES_2512, 0.1, 1W, 1%, TF, ROHS
12	R38	1	4.02k	1/10W	1	GENERIC	SM_RES_0603, 4.02k, 1/10W, 1%, TF, ROHS
13	R12, R15	2	590	1/10W	1	GENERIC	SM_RES_0603, 590, 1/10W, 1%, TF, ROHS
14	C12, C14	2	1800pF	16V	10	GENERIC	SM_CAP_0603, 1800PF, 16V, 10%, X7R, ROHS
15	C33, C36	2	330µF	6.3V	10	SANYO-POSCAP	SM_POLCAP_SMD, 6TPF330M9L, 330µF, 6.3V, 10%, CAP_7343
16	L1, L2	2	2.2µH		20	VISHAY	VISHAY_IHLP_5050CE_SMT-20%-IHLP-5050CE-01-2R2M,2.2µH, 29A, 20%, VISHAY_IHLP-5050CE

ISL62386xxEVAL1Z Evaluation Board Schematic

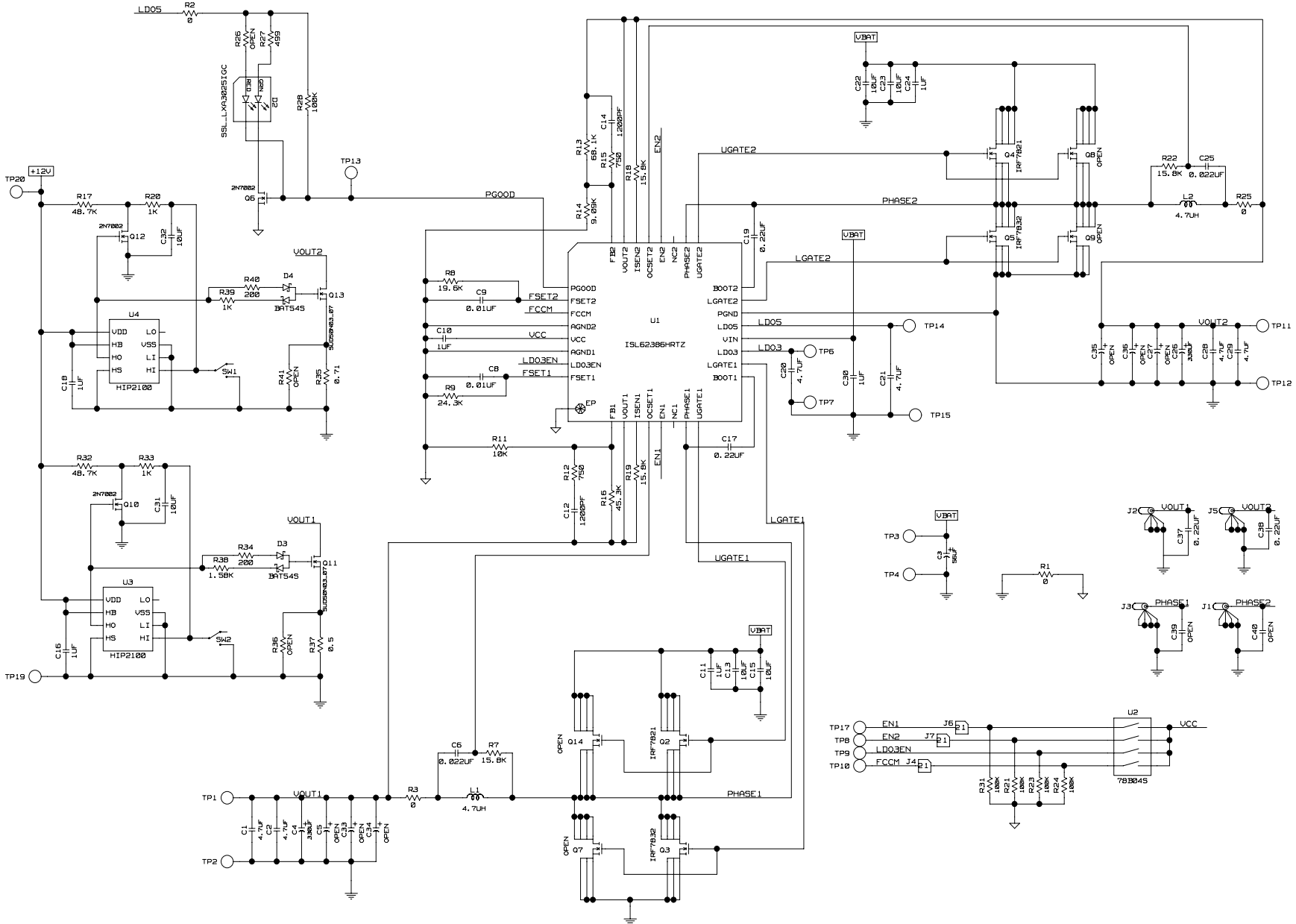

ISL62386xxEVAL1Z Evaluation Board Layout (Continued)

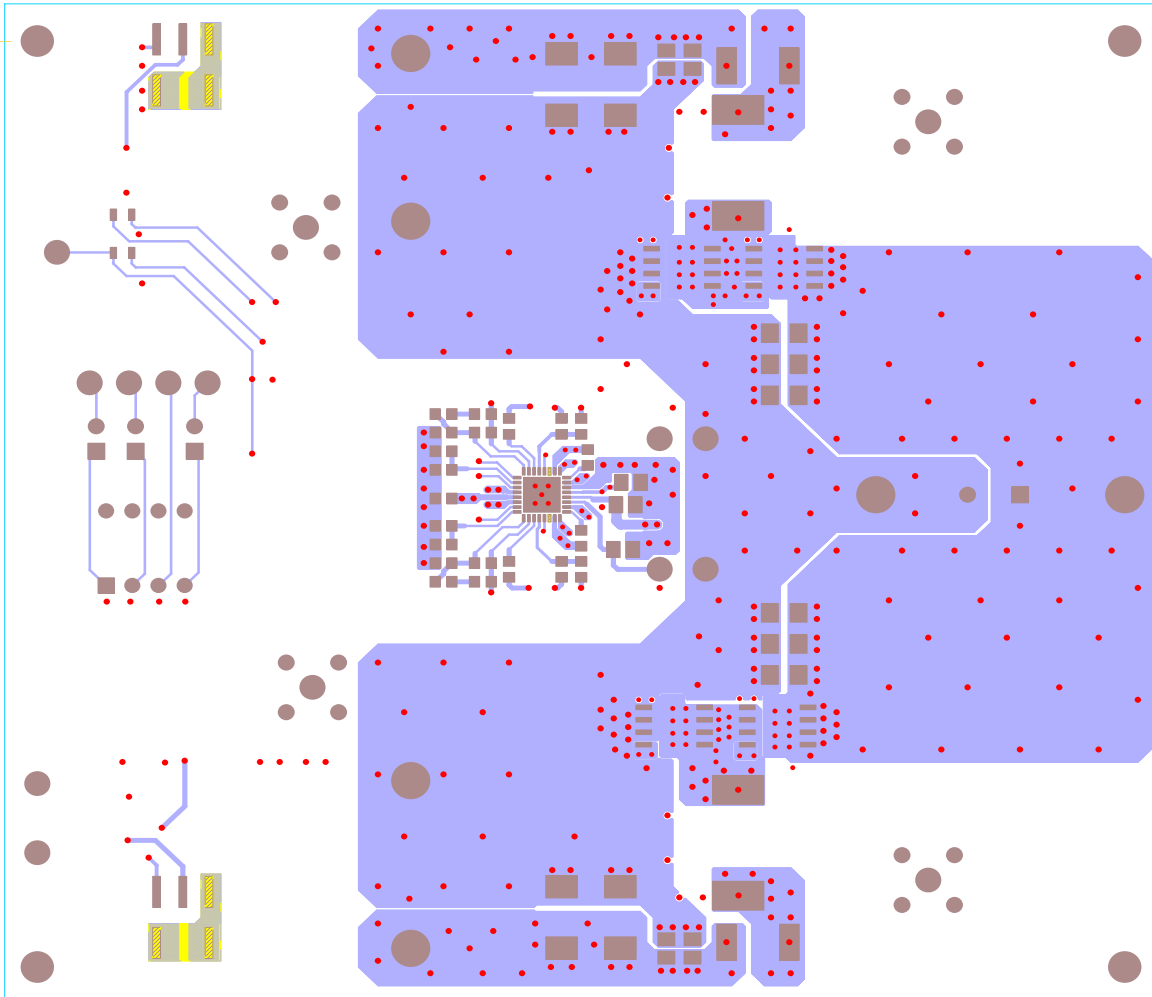

FIGURE 5. LAYER 1

ISL62386xxEVAL1Z Evaluation Board Layout (Continued)

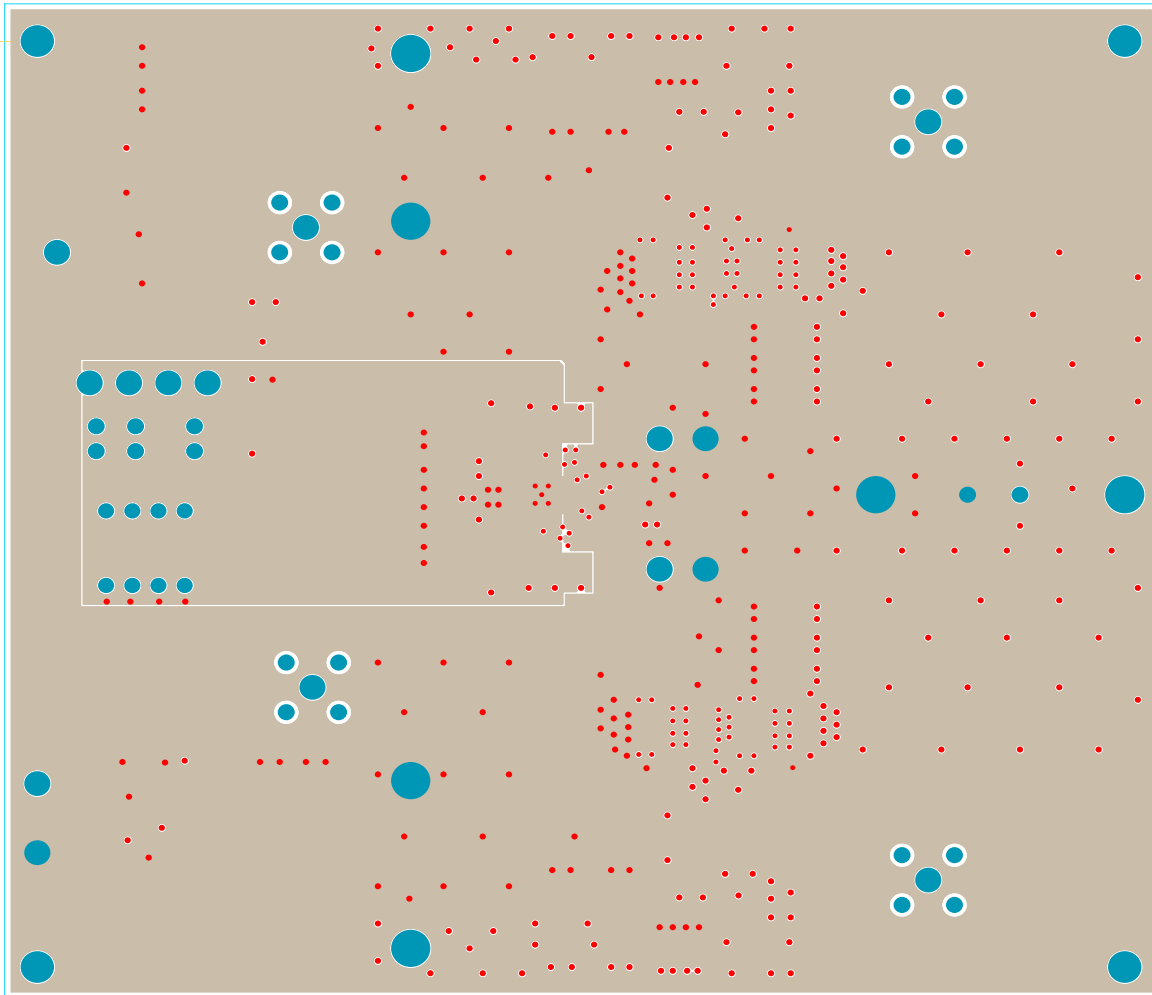

FIGURE 6. LAYER 2

ISL62386xxEVAL1Z Evaluation Board Layout (Continued)

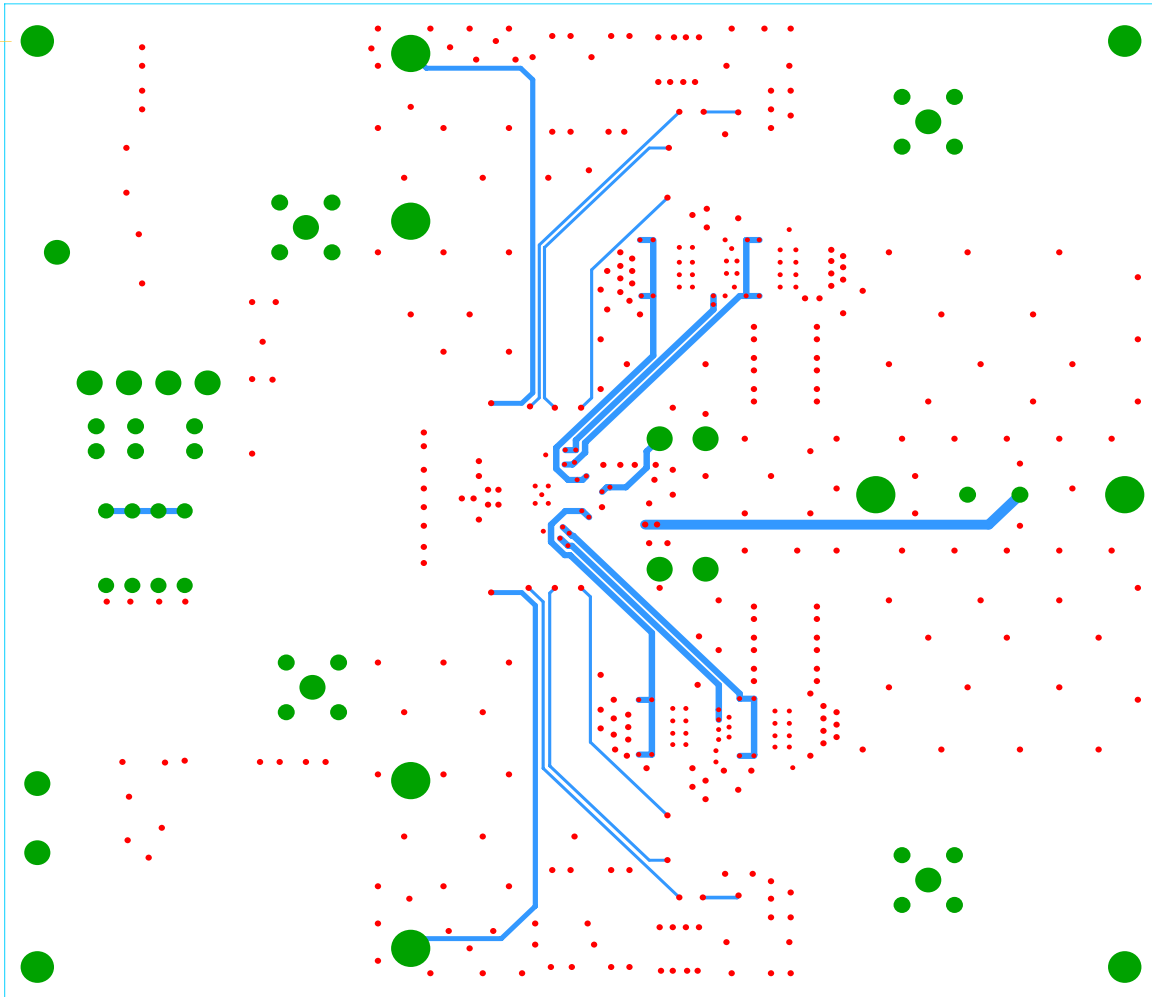

FIGURE 7. LAYER 3

ISL62386xxEVAL1Z Evaluation Board Layout (Continued)

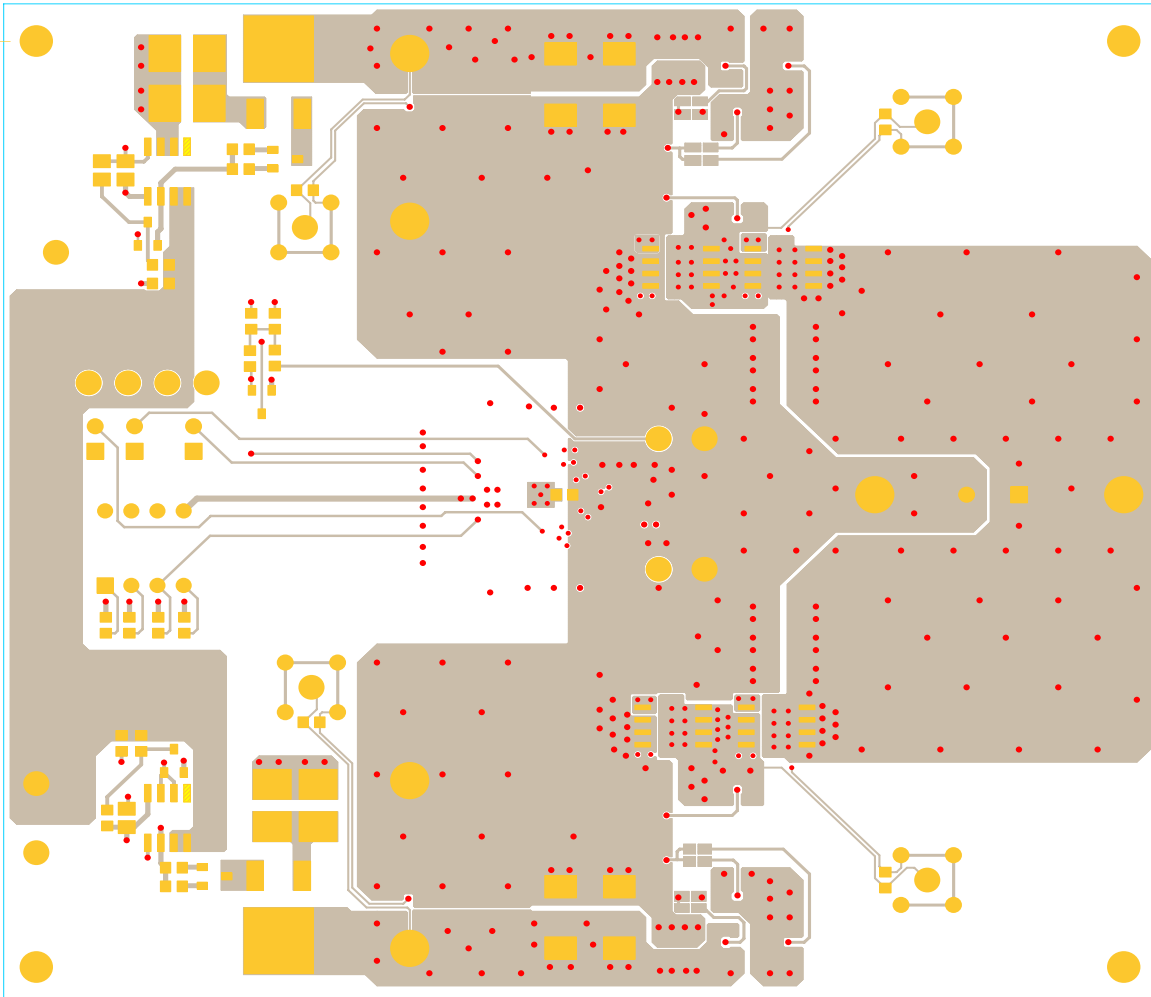

FIGURE 8. LAYER 4

Intersil Corporation reserves the right to make changes in circuit design, software and/or specifications at any time without notice. Accordingly, the reader is cautioned to verify that the Application Note or Technical Brief is current before proceeding.

For information regarding Intersil Corporation and its products, see www.intersil.com