

IT66121FN

Low Power Transmitter with HDMI1.4 3D

Preliminary Datasheet

Specification V0.99

ITE TECH. INC.

General Description

The IT66121 is a high-performance and low-power single channel HDMI transmitter, fully compliant with HDMI 1.3a, HDCP 1.2 and backward compatible to DVI 1.0 specifications. IT66121 also provide the HDMI1.4 3D feature, which enables direct 3D displays through an HDMI link. The IT66121 serves to provide the most cost-effective HDMI solution for DTV-ready consumer electronics such as set-top boxes, DVD players and A/V receivers, as well as DTV-enriched PC products such as notebooks and desktops, without compromising the performance. Its backward compatibility to DVI standard allows connectivity to myriad video displays such as LCD and CRT monitors, in addition to the ever-so-flourishing Flat Panel TVs.

Aside from the various video output formats supported, the IT66121 also supports 8 channels of I²S digital audio, with sampling rate up to 192kHz and sample size up to 24 bits. IT66121 also support S/PDIF input of up to 192kHz sampling rate.

The newly supported High-Bit Rate (HBR) audio by HDMI Specifications v1.3 is provided by the IT66121 in two interfaces: with the four I²S input ports or the S/PDIF input port. With both interfaces the highest possible HBR frame rate is supported at up to 768kHz

By default the IT66121 comes with integrated HDCP ROMs which are pre-programmed with HDCP keys that ensures secure digital content transmission. Users need not worry about the procurement and maintenance of the HDCP keys.

The IT66121 also provides a complete solution of Consumer Electronics Control (CEC) function. This optional CEC feature of HDMI specification allows the user to control two or more CEC-enabled devices through HDMI network. With IT66121 embedded CEC PHY, user can use high-level software API to easily implement all the necessary remote control commands. The CEC bus related protocol is handled by the CEC PHY which eliminates extra loading of the MCU.

Features

- Single channel HDMI transmitter
- Compliant with HDMI 1.3a, HDCP 1.2 and DVI 1.0 specifications
- Supporting pixel rates from 25MHz to 165MHz
 - ◆ DTV resolutions: 480i, 576i, 480p, 576p, 720p, 1080i up to 1080p
 - ◆ PC resolutions: VGA, SVGA, XGA, SXGA up to UXGA
- Various video input interface supporting digital video standards such as:
 - ◆ 24-bit RGB/YCbCr 4:4:4 with RB swap option

IT66121FN

- ◆ 16/20/24-bit YCbCr 4:2:2 with YC swap option
- ◆ 8/10/12-bit YCbCr 4:2:2 (CCIR-656)
- ◆ BTA-T1004 format
- ◆ DE-only interface
- ◆ DDR option
- Support HDMI1.4 3D feature
 - ◆ Frame packing mode up to 1080P@23.98/24Hz and 720P@59.94/60Hz
 - ◆ Top and Bottom up to 1080P@59.94/60Hz
 - ◆ Side-by-Side (Half) up to 1080P@59.94/60Hz
 - ◆ Side-by-Side (Full) up to 720P@59.94/60Hz
- Bi-direction Color Space Conversion (CSC) between RGB and YCbCr color spaces with programmable coefficients.
- Digital audio input interface supporting
 - ◆ audio sample rate: 32~192 kHz
 - ◆ sample size: 16~24 bits
 - ◆ four I²S interfaces supporting 8-channel audio
 - ◆ S/PDIF interface supporting PCM, Dolby Digital, DTS digital audio transmission at up to 192kHz
 - ◆ **Support for high-bit-rate (HBR) audio such as DTS-HD and Dolby TrueHD** through the four I²S interface or the S/PDIF interface, with frame rates as high as 768kHz
 - ◆ Compatible with IEC 60958 and IEC 61937
- Software programmable HDMI output current, enabling user to optimize the performance for fixed-cable systems or those with pre-defined cable length
- MCLK input is optional for audio operation. Users could opt to implement audio input interface with or without MCLK.
- Integrated pre-programmed HDCP keys
- Purely hardware HDCP engine increasing the robustness and security of HDCP operation
- Monitor detection through Hot Plug Detection and Receiver Termination Detection
- Embedded full-function pattern generator
- Intelligent, programmable power management
- **Embedded hardware controlled CEC PHY**
- **Ultra low power consumption, operation power is less than 70mw at 1080p@60Hz format.**
- 64-pin (9x9 mm) QFN package

IT66121FN

Pin Diagram

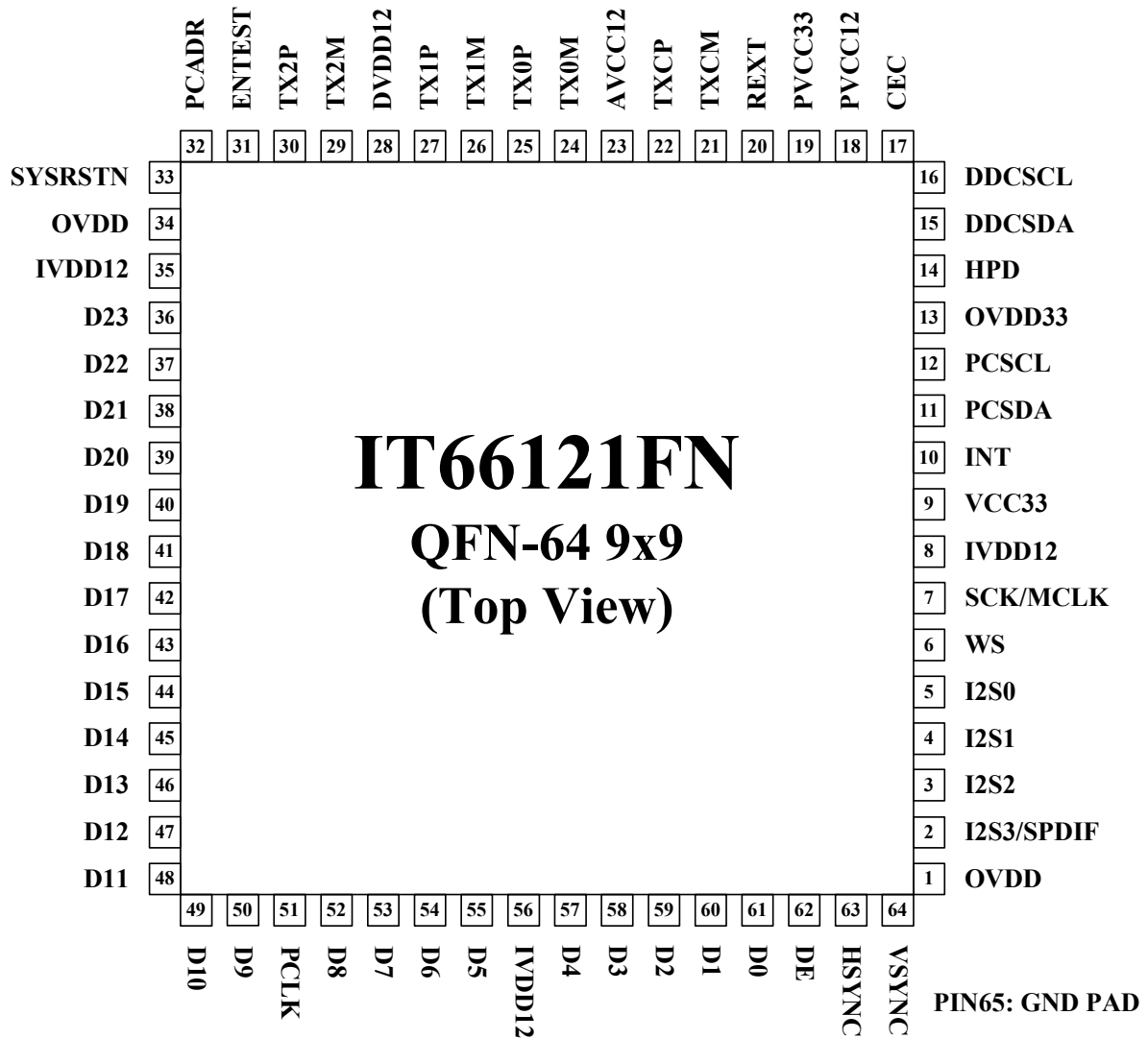

Figure 1. IT66121FN pin diagram

IT66121FN

Pin Description

Digital Video Input Pins

Pin Name	Direction	Description	Type	Pin No.
D[23:0]	Input	Digital video input pins.	LVTTL	36-50, 52-55, 57-61
DE	Input	Data enable	LVTTL	62
HSYNC	Input	Horizontal sync. signal	LVTTL	63
VSYNC	Input	Vertical sync. signal	LVTTL	64
PCLK	Input	Input data clock	LVTTL	51

Digital Audio Input Pins

Pin Name	Direction	Description	Type	Pin No.
SCK/MCLK	Input	I ² S serial clock input /SPDIF master clock input	LVTTL	7
WS	Input	I ² S word select input	LVTTL	6
I2S0	Input	I ² S 0 serial data input	LVTTL	5
I2S1	Input	I ² S 1 serial data input	LVTTL	4
I2S2	Input	I ² S 2 serial data input	LVTTL	3
I2S3/SPDIF	Input	I ² S 3 serial data input /SPDIF audio input	LVTTL	2

HDMI Interface Pins

Pin Name	Direction	Description	Type	Pin No.
CEC	I/O	CEC signal (5V-tolerant)	Schmitt	17
DDCSCL	I/O	I ² C Clock for DDC (5V-tolerant)	Schmitt	16
DDCSDA	I/O	I ² C Data for DDC (5V-tolerant)	Schmitt	15
HPD	Input	Hot Plug Detection (5V-tolerant)	LVTTL	14

TMDS front-end interface pins

Pin Name	Direction	Description	Type	Pin No.
TX2P	Analog	HDMI Channel 2 positive output	TMDS	30
TX2M	Analog	HDMI Channel 2 negative output	TMDS	29
TX1P	Analog	HDMI Channel 1 positive output	TMDS	27
TX1M	Analog	HDMI Channel 1 negative output	TMDS	26
TX0P	Analog	HDMI Channel 0 positive output	TMDS	25
TX0M	Analog	HDMI Channel 0 negative output	TMDS	24
TXCP	Analog	HDMI Clock Channel positive output	TMDS	22

IT66121FN

TXCM	Analog	HDMI Clock Channel negative output	TMDS	21
REXT	Analog	External resistor for setting TMDS output level. Default tied to AGND via a 4.7K-Ohm SMD resistor.	Analog	20

Programming Pins

Pin Name	Direction	Description	Type	Pin No.
PCSCL	Input	Serial Programming Clock for chip programming (5V-tolerant)	Schmitt	12
PCSDA	I/O	Serial Programming Data for chip programming (5V-tolerant)	Schmitt	11
INT#	Output	Interrupt output. Default active-low (5V-tolerant)	LVTTL	10

System Control Pins

Pin Name	Direction	Description	Type	Pin No.
ENTEST	Input	Must be tied low via a resistor.	LVTTL	31
PCADR	Input	Serial programming device address select	LVTTL	32
SYSRSTN	Input	Hardware reset pin. Active LOW	Schmitt	33

Power/Ground Pins

Pin Name	Description	Type	Pin No.
IVDD12	Digital logic power (1.2V)	Power	8, 35, 56
OVDD	I/O Pin power (1.8V or 2.5V or 3.3V)	Power	1, 34
OVDD33	5V-tolerant I/O power (3.3V)	Power	13
VCC33	Internal ROM power (3.3V)	Power	9
PVCC12	HDMI core PLL power (1.2V)	Power	18
PVCC33	HDMI core PLL power (3.3V)	Power	19
AVCC12	HDMI analog frontend power (1.2V)	Power	23
DVDD12	HDMI digital frontend power (1.2V)	Power	28
GND	Exposed ground pad	Ground	65

Functional Description

IT66121 is a low-power version of HDMI 1.3 transmitter and provides complete solutions for HDMI Source systems by implementing all the required HDMI functions. In addition, advanced processing algorithms are employed to optimize the performance of video processing such as color space conversion and YCbCr up/down-sampling. The following picture is the functional block diagram of IT66121, which describes clearly the data flow.

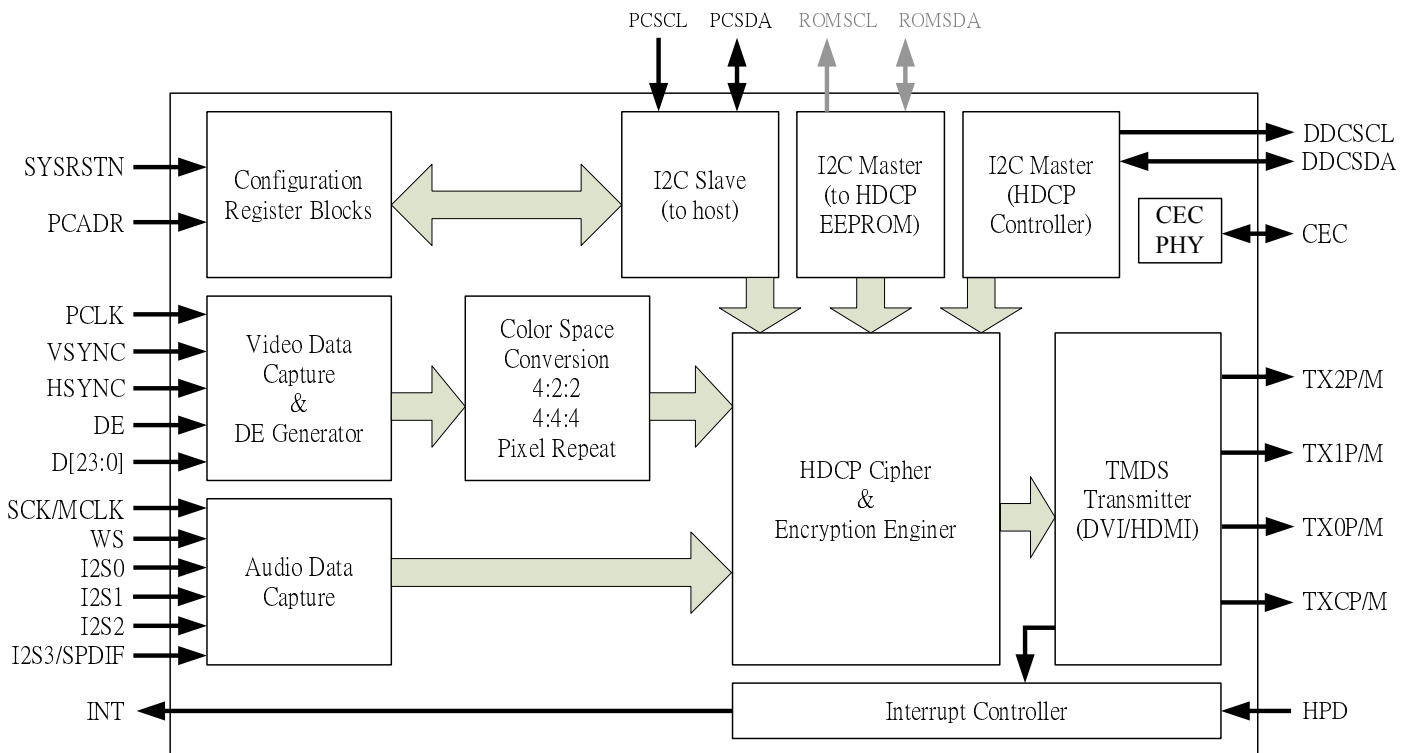

Figure 2. Functional block diagram of IT66121

Video Data Processing Flow

Figure 3 depicts the video data processing flow. For the purpose of retaining maximum flexibility, most of the block enabling and path bypassing are controlled through register programming. Please refer to IT66121 Programming Guide for detailed and precise descriptions.

As can be seen from Figure 3, the first step of video data processing is to prepare the video data (Data), data enable signal (DE), video clock (Clock), horizontal sync and vertical sync signals (H/VSYNC). While the video data and video clock are always readily available from input pins, the preparation of the data enable and sync signals require special extraction process (Embedded Ctrl. Signals Extraction & DE Generator) depending on the format of input video data.

All the data then undergo a series of video processing including color-space conversion and YCbCr

IT66121FN

up/down-sampling. Depending on the selected input and output video formats, different processing blocks are either enabled or bypassed via register control. For the sake of flexibility, this is all done in software register programming. Therefore, extra care should be taken in keeping the selected input-output format combination and the corresponding video processing block selection. Please refer to the IT66121 Programming Guide for suggested register setting.

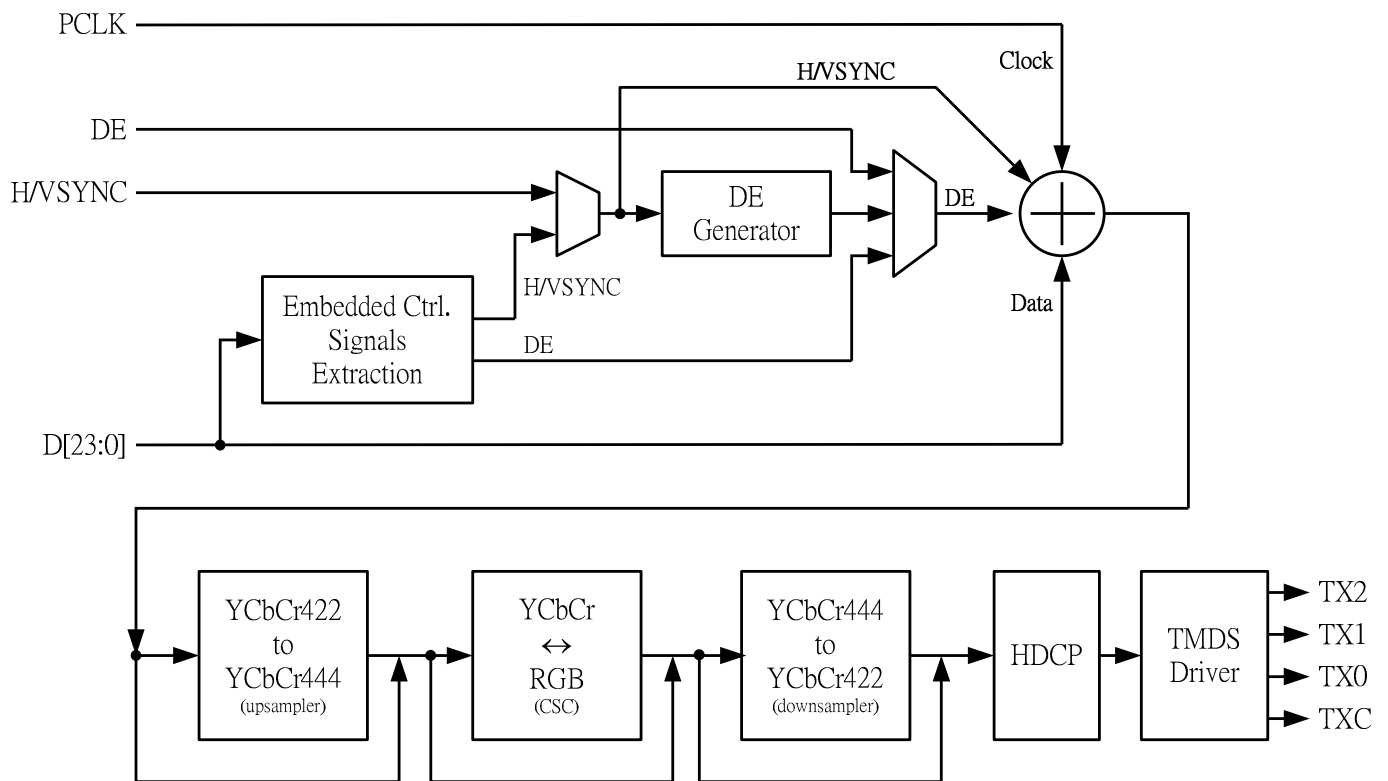

Figure 3. Video data processing flow of IT66121

Designated as D[23:0], the input video data could take on bus width of 8 bits to 24 bits. This input interface could be configured through register setting to provide various data formats as listed in Table 1.

Although not explicitly depicted in Figure 3, input video clock (PCLK) can be configured to be multiplied by 0.5, 1, 2 or 4, so as to support special formats such as CCIR-656 and pixel-repeating. This is also enabled by software programming.

General description of block functions is as follows:

Extraction of embedded control signals (Embedded Ctrl. Signals Extraction)

Input video formats with only embedded sync signals rely on this block to derive the proper Hsync, Vsync and DE signals. Specifically, CCIR-656 video stream includes Start of Active Video (SAV) and

IT66121FN

End of Active Video (EAV) that this block uses to extract the required control signals.

Generation of data enable signal (DE Generator)

DE signal defines the region of active video data. In cases where the video decoders supply no such DE signals to IT66121, this block is used to generate appropriate DE signal from Hsync, Vsync and Clock.

Upsampling (YCbCr422 to YCbCr444)

In cases where input signals are in YCbCr 4:2:2 format and output is selected as 4:4:4, this block is enabled to do the upsampling.

Bi-directional Color Space Conversion (YCbCr ↔ RGB)

Many video decoders only offer YCbCr outputs, while DVI 1.0 supports only RGB color space. In order to offer full compatibility between various Source and Sink combination, this block offers bi-directional RGB ↔ YCbCr color space conversion (CSC). To provide maximum flexibility, the matrix coefficients of the CSC engine in IT66121 are fully programmable. Users of IT66121 could elect to employ their preferred conversion formula.

Downsampling (YCbCr444 to YCbCr422)

In cases where input signals are in YCbCr 4:4:4 format and output is selected as YCbCr 4:2:2, this block is enabled to do the downsampling.

HDCP engine (HDCP)

The HDCP engine in IT66121 handles all the processing required by HDCP mechanism in hardware. Software intervention is not necessary except checking for revocation. Preprogrammed HDCP keys are also embedded in IT66121. Users need not worry about the purchasing and management of the HDCP keys.

TMDS driver (TMDS Driver)

The final stop of the data processing flow is TMDS serializer. The TMDS driver serializes the input parallel data and drive out the proper electrical signals to the HDMI cable. The output current level is controlled through connecting a precision resistor of proper value to Pin 20 (REXT).

IT66121FN

Supported Input Video Formats

Table 1 lists the input video formats supported by IT66121.

Color Space	Video Format	Bus Width	DDR/SDR	Hsync/Vsync	Input Pixel clock frequency (MHz)							
					480i	480p	XGA	720p	1080i	SXGA	1080p	UXGA
RGB	4:4:4	24	SDR	Separate	13.5	27	65	74.25	74.25	108	148.5	162
		12	DDR	Separate	13.5	27	65	74.25	74.25			
		24	DDR	Separate		13.5	32.5	37.125	37.125	54	74.25	81
YCbCr	4:4:4	24	SDR	Separate	13.5	27	65	74.25	74.25	108	148.5	162
		12	DDR	Separate	13.5	27	65	74.25	74.25			
		24	DDR	Separate		13.5	32.5	37.125	37.125	54	74.25	81
	4:2:2	16/20/24	SDR	Separate	13.5	27	65	74.25	74.25	108	148.5	162
				Embedded	13.5	27	65	74.25	74.25	108	148.5	162
		16/20/24	DDR	Separate		13.5	32.5	37.125	37.125	54	74.25	81
				Embedded		13.5	32.5	37.125	37.125	54	74.25	81
		8/10/12	SDR	Separate	27	54	130	148.5	148.5			
				Embedded	27	54	130	148.5	148.5			
	8/10/12	DDR	Separate	13.5	27	65	74.25	74.25				
			Embedded	13.5	27	65	74.25	74.25				

Table 1. Input video formats supported by IT66121

Notes:

1. Table cells that are left blanks are those format combinations that are not supported by IT66121.
2. Embedded sync signals are defined by CCIR-656 standard, using SAV/EAV sequences of FF, 00, 00, XY.
3. The original pixel clock of 480i is 13.5MHz. HDMI standard mandates that a 27MHz pixel clock be used and pixel repeating is employed to keep the frequency range of the HDMI link within control.

Audio Data Capture and Processing

IT66121 takes in four I²S inputs as well as one S/PDIF input of audio data. The four I²S inputs allow transmission of 8-channel uncompressed audio data at up to 192kHz sample rate. The S/PDIF input allows transmission of uncompressed PCM data (IEC 60958) or compressed multi-channel data (IEC 61937) at up to 192kHz.

Note that MCLK input is optional for the IT66121. By default IT66121 generates the MCLK internally to process the audio. Neither I²S nor S/PDIF inputs requires external MCLK signal. However, if the jitter or the duty cycle of the input S/PDIF is considerable, coherent external MCLK input is recommended and such configuration could be enabled through register setting. Refer to IT66121 Programming Guide for such setting.

IT66121FN

High-Bit-Rate (HBR) Audio is first introduced in the HDMI 1.3 standard. It is called upon by high-end audio system such as DTS-HD and Dolby TrueHD. No specific interface is defined by the HBR standard. The IT66121 supports HBR audio in two ways. One is to employ the four I²S inputs simultaneously, where the original streaming HBR audio is broken into four parallel data streams before entering the IT66121. The other is to use the S/PDIF input port. Since the data rate here is as high as 98.304Mbps, a coherent MCLK is required in this application.

Interrupt Generation

The system micro-controller should take in the interrupt signal output by IT66121 at PIN 10 (INT). INT pin can be configured as Push-pull or Tristate mode depending on user's application. IT66121 generates an interrupt signal with events involving the following signals or situations:

1. Hot-plug detection (Pin 14, HPD) experiences state changes.
2. Receiver detection circuit reports the presence or absence of an active termination at the TMDS Clock Channel (RxSENDETECT)
3. DDC bus is hanged for any reasons
4. Audio FIFO overflows
5. HDCP authentication fails
6. Audio/Video data is stable or not

A typical initialization of HDMI link should be based on interrupt signal and appropriate register probing. Recommended flow is detailed in IT66121 Programming Guide. Simply put, the microcontroller should monitor the HPD status first. Upon valid HPD event, move on to check RxSENDETECT register to see if the receiver chip is ready for further handshaking. When RxSENDETECT is asserted, start reading EDID data through DDC channels and carry on the rest of the handshaking subsequently.

If the micro-controller makes no use of the interrupt signal as well as the above-mentioned status registers, the link establishment might fail. Please do follow the suggested initialization flow recommended in IT66121 Programming Guide.

Configuration and Function Control

IT66121 includes two serial programming ports by default (i.e. with embedded HDCP keys): one for interfacing with micro-controller, the other for accessing the DDC channels of HDMI link.

The serial programming interface for interfacing the micro-controller is a slave interface, comprising PCSCSCL (Pin 12) and PCSDSA (Pin 11). The micro-controller uses this interface to monitor all the statuses and control all the functions. Two device addresses are available, depending on the input logic level of PCADR (Pin 32). If PCADR is pulled high by the user, the device address is **0x9A**. If pulled low, **0x98**.

The I²C interface for accessing the DDC channels of the HDMI link is a master interface, comprising DDCSCL (Pin 16) and DDCSDA (Pin 15). IT66121 uses this interface to read the EDID data and perform HDCP authentication protocol with the sink device over the HDMI cable.

For temporarily storing the acquired EDID data, IT66121 includes a 32 bytes dedicated FIFO. The micro-controller may command IT66121 to acquire 32 bytes of EDID information, read it back and then continue to read the next 32 bytes until getting all necessary EDID information.

The HDCP protocol of IT66121 is completely implemented in hardware. No software intervention is needed except for revocation list checking. Various HDCP-related statuses are stored in HDCP registers for the reference of micro-controller. Refer to IT66121 Programming Guide for detailed register descriptions. The HDCP Standard also specifies a special message read protocol other than the standard I²C protocol. See Figure 4 for checking HDCP port link integrity.

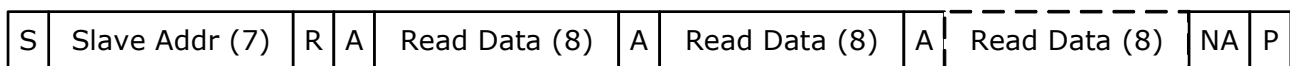

S=Start; R=Read; A=Ack; NA=No Ack; P=Stop

Figure 4. HDCP port link integrity message read

All serial programming interfaces conform to standard I²C transactions and operate at up to 100kHz.

IT66121FN

Electrical Specifications

Absolute Maximum Ratings

Symbol	Parameter	Min.	Typ	Max	Unit
IVDD12	Core logic supply voltage	-0.5		1.5	V
OVDD33	5V-tolerance I/O pins supply voltage	-0.3		4.0	V
OVDD	1.8V I/O pins supply voltage (OVDD=1.8V)	-0.3		2.5	V
OVDD	2.5V I/O pins supply voltage (OVDD=2.5V)	-0.3		3.2	V
OVDD	3.3V I/O pins supply voltage (OVDD=3.3V)	-0.3		4.0	V
VCC33	ROM supply voltage	-0.3		4.0	V
AVCC12	HDMI analog frontend supply voltage	-0.5		1.5	V
PVCC12	HDMI core PLL supply voltage	-0.5		1.5	V
PVCC33	HDMI core PLL supply voltage	-0.3		4.0	V
DVDD12	HDMI AFE digital supply voltage	-0.5		1.5	V
V _I	Input voltage	-0.3		OVDD+0.3	V
V _O	Output voltage	-0.3		OVDD+0.3	V
T _J	Junction Temperature			125	°C
T _{STG}	Storage Temperature	-65		150	°C
ESD_HB	Human body mode ESD sensitivity	2000			V
ESD_MM	Machine mode ESD sensitivity	200			V

Notes:

1. Stresses above those listed under Absolute Maximum Ratings might result in permanent damage to the device.
2. Refer to Functional Operation Conditions for normal operation.

Functional Operation Conditions

Symbol	Parameter	Min.	Typ	Max	Unit
IVDD12	Core logic supply voltage	1.14	1.2	1.26	V
OVDD33	I/O pins supply voltage	3.0	3.3	3.6	V
OVDD	1.8V I/O pins supply voltage	1.62	1.8	1.98	V
	2.5V I/O pins supply voltage	2.25	2.5	2.75	V
	3.3V I/O pins supply voltage	3.0	3.3	3.6	V
VCC33	ROM supply voltage	3.0	3.3	3.6	V
AVCC12	HDMI analog frontend supply voltage	1.14	1.2	1.26	V
PVCC12	HDMI core PLL supply voltage	1.14	1.2	1.26	V
PVCC33	HDMI core PLL supply voltage	3.0	3.3	3.6	V
DVDD12	HDMI AFE digital supply voltage	1.14	1.2	1.26	V
V _{CCNOISE}	Supply noise			100	mV _{pp}
T _A	Ambient temperature	0	25	70	°C

IT66121FN

Θ_{ja}	Junction to ambient thermal resistance			40	°C/W
---------------	--	--	--	----	------

Notes:

1. AVCC12, PVCC12 and PVCC33 should be regulated.
2. See System Design Consideration for supply decoupling and regulation.

IT66121FN

DC Electrical Specification

Under functional operation conditions

Symbol	Parameter	Pin Type	For 1.8V OVDD			For 2.5V OVDD			For 3.3V OVDD			Unit
			Min	Typ	Max	Min	Typ	Max	Min	Typ	Max	
V _{IH}	Input low voltage ¹	LVTTL			0.6			0.7			0.8	V
V _{IL}	Input high voltage ¹	LVTTL	1.2			1.7			2.0			V
V _{T-}	Schmitt trigger negative going threshold voltage ¹	Schmitt	0.63	0.75		0.94	1.06		1.22	1.39		V
V _{T+}	Schmitt trigger positive going threshold voltage ¹	Schmitt		1.05	1.14		1.35	1.48		1.70	1.92	V
V _{OL}	Output low voltage ¹	LVTTL			0.4			0.4			0.4	V
V _{OH}	Output high voltage ¹	LVTTL	1.4			2.1			2.9			V
I _{IN}	Input leakage current ¹	all	-10		+10	-10		+10	-10		+10	μA
I _{OZ}	Tri-state output leakage current ¹	all	-10		+10	-10		+10	-10		+10	μA
I _{OL}	Serial programming output sink current ²	Schmitt							2.5		10	mA
V _{swing}	TMDS output single-ended swing ³	TMDS	400		600	400		600	400		600	mV
I _{OFF}	Single-ended standby output current ³	TMDS			10			10			10	μA

Notes:

1. Guaranteed by I/O design.
2. The serial programming output ports are not real open-drain drivers. Sink current is guaranteed by I/O design under the condition of driving the output pin with 0.2V. In a real serial programming environment, multiple devices and pull-up resistors could be present on the same bus, rendering the effective pull-up resistance much lower than that specified by the I²C Standard. When set at maximum current, the serial programming output ports of IT66121 are capable of pulling down an effective pull-up resistance as low as 500Ω connected to 5V termination voltage to the standard I²C V_{IL}. When experiencing insufficient low level problem, try setting the current level to higher than default. Refer to IT66121 Programming Guide for proper register setting.
3. Limits defined by HDMI standard

Audio AC Timing Specification

Under functional operation conditions

Symbol	Parameter	Conditions	Min	Typ	Max	Unit
F _{S_I2S}	I ² S sample rate	Up to 8 channels	32		192	kHz
F _{S_SPDIF}	S/PDIF sample rate	2 channels	32		192	kHz

IT66121FN

Video AC Timing Specification

Under functional operation conditions

Symbol	Parameter	Conditions	Min	Typ	Max	Unit
T_{pixel}	PCLK pixel clock period ¹	Single-edged clocking	6.06		40	ns
F_{pixel}	PCLK pixel clock frequency ¹		25		165	MHz
T_{CDE}	PCLK dual-edged clock period ²	Dual-edged clocking	13.47		40	ns
F_{CDE}	PCLK dual-edged clock frequency ²		25		74.25	MHz
T_{PDUTY}	PCLK clock duty cycle		40%		60%	
T_{PJ}	PCLK worst-case jitter				2.0	ns
T_{S}	Video data setup time ³	Single-edged clocking	1.5			ns
T_{H}	Video data hold time ³		0.7			ns
T_{SDE}	Video data setup time ³	Dual-edged clocking	1.5			ns
T_{HDE}	Video data hold time ³		0.7			ns

Notes:

1. F_{pixel} is the inverse of T_{pixel} . Operating frequency range is given here while the actual video clock frequency should comply with all video timing standards. Refer to Table 1 for supported video timings and corresponding pixel frequencies.
2. 12-bit dual-edged clocking is supported up to 74.5MHz of PCLK frequency, which covers 720p/1080i.
3. All setup time and hold time specifications are with respect to the latching edge of PCLK selected by the user through register programming.

IT66121FN

Operation Supply Current Specification

● Normal Operation Mode

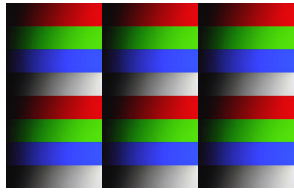
TYPICAL Mode TTL input test 3.3V, 2.5V and 1.8V						
Resolution	Mode	HDCP	Video In/Out Format	Audio	Deep Color	Video Pattern
480P@60Hz	HDMI	On	YUV444 to RGB444	48K2Ch	8bits	
720P@60Hz						
1080P@60Hz						
1600x1200@60Hz	DVI	Off	No CSC	Off	8bits	

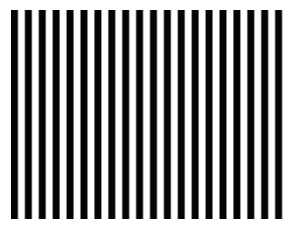
MAX Mode TTL input test 3.3V, 2.5V and 1.8V						
Resolution	Mode	HDCP	Video In/Out Format	Audio	Deep Color	Video Pattern
480P@60Hz	HDMI	On	YUV444to RGB444	192K2Ch	8bits	
720P@60Hz						
1080P@60Hz						
1600x1200@60Hz	DVI	Off	No CSC	Off	8bits	

Symbol	Video Timing	PCLK(MHz)	TYPICAL	MAX	Unit
I _{OVDD33}	480P60 8-bit	27.0	0.07	0.07	mA
	720P60 8-bit	74.25	0.07	0.07	mA
	1080P60 8-bit	148.5	0.07	0.07	mA
	1600x1200P60 8-bit	162.0	0.07	0.07	mA
I _{VCC33}	480P60 8-bit	27.0	0.04	0.04	mA
	720P60 8-bit	74.25	0.04	0.04	mA
	1080P60 8-bit	148.5	0.04	0.04	mA
	1600x1200P60 8-bit	162.0	0.00	0.00	mA
I _{PVCC33}	480P60 8-bit	27.0	1.68	1.68	mA

IT66121FN

	720P60 8-bit	74.25	5.77	5.77	mA
	1080P60 8-bit	148.5	3.16	3.16	mA
	1600x1200P60 8-bit	162.0	3.53	3.53	mA
I _{IVDD12}	480P60 8-bit	27.0	4.77	6.10	mA
	720P60 8-bit	74.25	11.02	13.24	mA
	1080P60 8-bit	148.5	21.22	24.63	mA
	1600x1200P60 8-bit	162.0	16.745	20.6	mA
I _{DVDD12}	480P60 8-bit	27.0	1.36	1.36	mA
	720P60 8-bit	74.25	3.44	3.44	mA
	1080P60 8-bit	148.5	6.69	6.69	mA
	1600x1200P60 8-bit	162.0	7.2	7.2	mA
I _{AVCC12}	480P60 8-bit	27.0	9.95	9.95	mA
	720P60 8-bit	74.25	10.69	10.69	mA
	1080P60 8-bit	148.5	11.84	11.84	mA
	1600x1200P60 8-bit	162.0	12.0	12.0	mA
I _{PVCC12}	480P60 8-bit	27.0	0.87	0.87	mA
	720P60 8-bit	74.25	2.32	2.32	mA
	1080P60 8-bit	148.5	2.6	2.6	mA
	1600x1200P60 8-bit	162.0	2.85	2.85	mA

■ When OVDD=3.3V

I _{OVDD} TTL input is 3.3V	480P60 8-bit	27.0	0.13	0.15	mA
	720P60 8-bit	74.25	0.3	0.37	mA
	1080P60 8-bit	148.5	0.49	0.65	mA
	1600x1200P60 8-bit	162.0	0.44	0.75	mA
P _{TOTAL} TTL input is 3.3V	480P60 8-bit	27.0	26.676	28.338	mW
	720P60 8-bit	74.25	53.358	56.253	mW
	1080P60 8-bit	148.5	63.228	68.848	mW
	1600x1200P60 8-bit	162.0	63.84	65.535	mW

■ When OVDD=2.5V

I _{OVDD} TTL input is 2.5V	480P60 8-bit	27.0	0.036	0.065	mA
	720P60 8-bit	74.25	0.132	0.164	mA
	1080P60 8-bit	148.5	0.248	0.328	mA
	1600x1200P60 8-bit	162.0	0.264	0.461	mA
P _{TOTAL}	480P60 8-bit	27.0	25.6752	27.372	mW

IT66121FN

TTL input is 2.5V	720P60 8-bit	74.25	50.7324	53.6658	mW
	1080P60 8-bit	148.5	60.4056	65.1216	mW
	1600x1200P60 8-bit	162.0	60.7368	62.6682	mW

■ When OVDD=1.8V

I _{OVDD} TTL input is 1.8V	480P60 8-bit	27.0	0.000	0.000	mA
	720P60 8-bit	74.25	0.043	0.052	mA
	1080P60 8-bit	148.5	0.115	0.172	mA
	1600x1200P60 8-bit	162.0	0.121	0.228	mA
P _{TOTAL} TTL input is 1.8V	480P60 8-bit	27.0	25.632	27.294	mW
	720P60 8-bit	74.25	50.6256	53.5314	mW
	1080P60 8-bit	148.5	60.246	64.933	mW
	1600x1200P60 8-bit	162.0	60.5652	62.3886	mW

● Standby Mode

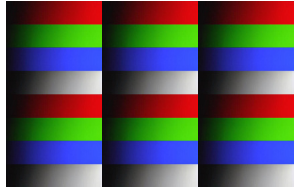
Standby Mode					
TTL input test 3.3V, 2.5V and 1.8V					
Resolution	HDCP	Video In/Out Format	Audio	Deep Color	Video Pattern
1080P@60Hz	On	YUV444toRGB444	On	8bits	

Symbol	Standby PCLK / No PCLK	Unit	Symbol	Standby PCLK / No PCLK	Unit
I _{OVDD33}	0.023 / 0.023	mA	3.3V	0.023 / 0.023	mA
I _{VCC33}	0.000 / 0.000	mA			
I _{PVCC33}	0.000 / 0.000	mA			
I _{IVDD12}	0.539 / 0.114	mA	1.2V	0.846 / 0.287	mA
I _{DVDD12}	0.174 / 0.173	mA			
I _{AVCC12}	0.000 / 0.000	mA			
I _{PVCC12}	0.133 / 0.000	mA			
I _{OVDD (3.3V)}	0.102 / 0.000	mA	I _{OVDD (3.3V)}	0.102 / 0.000	mA
I _{OVDD (2.5V)}	0.056 / 0.000	mA	I _{OVDD (2.5V)}	0.056 / 0.000	mA
I _{OVDD (1.8V)}	0.016 / 0.000	mA	I _{OVDD (1.8V)}	0.016 / 0.000	mA
TTL input is 3.3V		P _{TOTAL}	1.4277 / 0.4203		mW

IT66121FN

TTL input is 2.5V	P _{TOTAL}	1.2311 / 0.4203	mW
TTL input is 1.8V	P _{TOTAL}	1.1199 / 0.4203	mW

Notes:

1. P_{TOTAL} are calculated by multiplying the supply currents with their corresponding supply voltage and summing up all the items.

Video Data Bus Mappings

IT66121 supports various input data mappings and formats, including those with embedded control signals only. Corresponding register setting is mandatory for any chosen input data mappings. Refer to IT66121 Programming Guide for detailed instruction.

Color Space	Video Format	Bus Width	SDR/DDR	H/Vsync	Clocking	Table	Figure
RGB	4:4:4	24	SDR	Separate	1X	3	5
		12	DDR			12	12
		24	DDR			0.5X	13
YCbCr	4:4:4	24	SDR	Separate	1X	3	5
		12	DDR			12	12
		24	DDR			0.5X	13
	4:2:2	16/20/24	SDR	Separate	1X	4	6
				Embedded		5	7
		16/20/24	DDR	Separate	0.5X	14	14
				Embedded		Note 1	
		8/10/12	SDR	Separate	2X	8	10
				Embedded		7	9
		8/10/12	DDR	Separate	1X	Note 2	
				Embedded		15	15

Table 2. Input video format supported by IT66121

Notes:

1. The mapping of this format is the same as Table 5 and the timing diagram is similar to Figure 14 except the syncs are embedded.
2. The mapping of this format is the same as Table 8 and the timing diagram is similar to Figure 15 except the syncs are separated.

With certain input formats, not all 24 data input pins are used. In that case, it is recommended to tie the unused input pins to ground.

IT66121FN

24-bit RGB/YCbCr444 (Separate Syncs)

These are the simplest formats, with a complete definition of every pixel in each clock period. Timing diagram is depicted in Fig.5.

Pin Name	RGB	YCbCr
D0	B0	Cb0
D1	B1	Cb1
D2	B2	Cb2
D3	B3	Cb3
D4	B4	Cb4
D5	B5	Cb5
D6	B6	Cb6
D7	B7	Cb7
D8	G0	Y0
D9	G1	Y1
D10	G2	Y2
D11	G3	Y3
D12	G4	Y4
D13	G5	Y5
D14	G6	Y6
D15	G7	Y7
D16	R0	Cr0
D17	R1	Cr1
D18	R2	Cr2
D19	R3	Cr3
D20	R4	Cr4
D21	R5	Cr5
D22	R6	Cr6
D23	R7	Cr7
HSYNC	HSYNC	HSYNC
VSYNC	VSYNC	VSYNC
DE	DE	DE

Table 3. Mappings of 24-bit RGB/YCbCr444 (separate syncs)

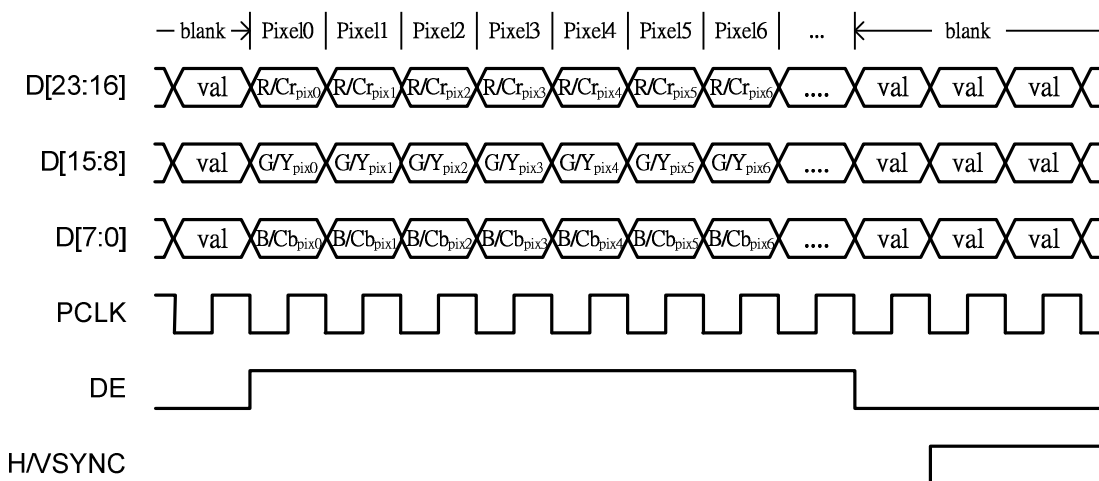

Figure 5. 24-bit RGB/YCbCr444 (separate syncs)

IT66121FN

16/20/24-bit YCbCr422 with Separate Syncs

YCbCr 4:2:2 format does not have one complete pixel for every clock period. Luminance channel (Y) is given for every pixel, while the two chroma channels are given alternatively on every other clock period. The DE period should contain an even number of clock periods.

Pin Name	YCbCr 4:2:2 16-bit		YCbCr 4:2:2 20-bit		YCbCr 4:2:2 24-bit	
	Pixel#2N	Pixel#2N+1	Pixel#2N	Pixel#2N+1	Pixel#2N	Pixel#2N+1
D0	grounded	grounded	grounded	grounded	Y0	Y0
D1	grounded	grounded	grounded	grounded	Y1	Y1
D2	grounded	grounded	Y0	Y0	Y2	Y2
D3	grounded	grounded	Y1	Y1	Y3	Y3
D4	Y0	Y0	Y2	Y2	Y4	Y4
D5	Y1	Y1	Y3	Y3	Y5	Y5
D6	Y2	Y2	Y4	Y4	Y6	Y6
D7	Y3	Y3	Y5	Y5	Y7	Y7
D8	Y4	Y4	Y6	Y6	Y8	Y8
D9	Y5	Y5	Y7	Y7	Y9	Y9
D10	Y6	Y6	Y8	Y8	Y10	Y10
D11	Y7	Y7	Y9	Y9	Y11	Y11
D12	grounded	grounded	grounded	grounded	Cb0	Cr0
D13	grounded	grounded	grounded	grounded	Cb1	Cr1
D14	grounded	grounded	Cb0	Cr0	Cb2	Cr2
D15	grounded	grounded	Cb1	Cr1	Cb3	Cr3
D16	Cb0	Cr0	Cb2	Cr2	Cb4	Cr4
D17	Cb1	Cr1	Cb3	Cr3	Cb5	Cr5
D18	Cb2	Cr2	Cb4	Cr4	Cb6	Cr6
D19	Cb3	Cr3	Cb5	Cr5	Cb7	Cr7
D20	Cb4	Cr4	Cb6	Cr6	Cb8	Cr8
D21	Cb5	Cr5	Cb7	Cr7	Cb9	Cr9
D22	Cb6	Cr6	Cb8	Cr8	Cb10	Cr10
D23	Cb7	Cr7	Cb9	Cr9	Cb11	Cr11
HSYNC	HSYNC	HSYNC	HSYNC	HSYNC	HSYNC	HSYNC
VSYNC	VSYNC	VSYNC	VSYNC	VSYNC	VSYNC	VSYNC
DE	DE	DE	DE	DE	DE	DE

Table 4. Mappings of 16/20/24-bit YCbCr422 with separate syncs

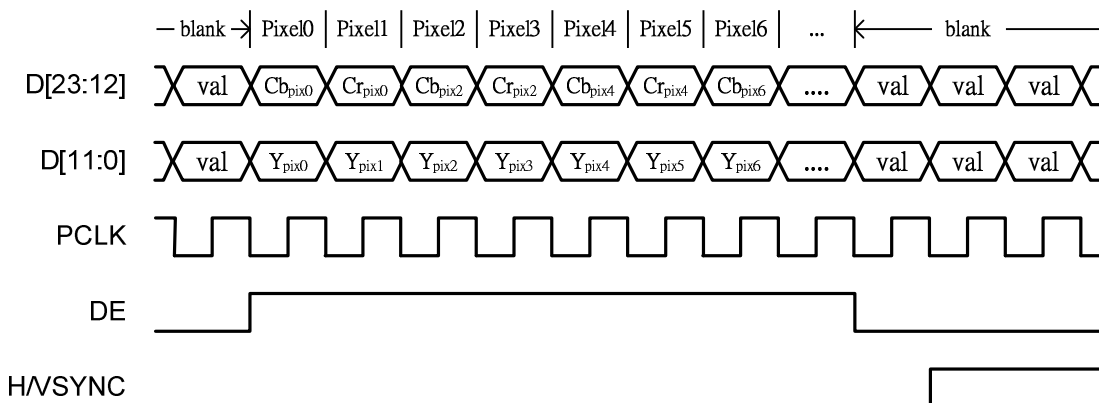

Figure 6. 16/20/24-bit YCbCr422 with separate syncs

IT66121FN

16/20/24-bit YCbCr422 with Embedded Syncs

This is similar to the previous format. The only difference is that the syncs are embedded. Bus width could be 16-bit, 20-bit or 24-bit.

Pin Name	YCbCr 4:2:2 16-bit		YCbCr 4:2:2 20-bit		YCbCr 4:2:2 24-bit	
	Pixel#2N	Pixel#2N+1	Pixel#2N	Pixel#2N+1	Pixel#2N	Pixel#2N+1
D0	grounded	grounded	grounded	grounded	Y0	Y0
D1	grounded	grounded	grounded	grounded	Y1	Y1
D2	grounded	grounded	Y0	Y0	Y2	Y2
D3	grounded	grounded	Y1	Y1	Y3	Y3
D4	Y0	Y0	Y2	Y2	Y4	Y4
D5	Y1	Y1	Y3	Y3	Y5	Y5
D6	Y2	Y2	Y4	Y4	Y6	Y6
D7	Y3	Y3	Y5	Y5	Y7	Y7
D8	Y4	Y4	Y6	Y6	Y8	Y8
D9	Y5	Y5	Y7	Y7	Y9	Y9
D10	Y6	Y6	Y8	Y8	Y10	Y10
D11	Y7	Y7	Y9	Y9	Y11	Y11
D12	grounded	grounded	grounded	grounded	Cb0	Cr0
D13	grounded	grounded	grounded	grounded	Cb1	Cr1
D14	grounded	grounded	Cb0	Cr0	Cb2	Cr2
D15	grounded	grounded	Cb1	Cr1	Cb3	Cr3
D16	Cb0	Cr0	Cb2	Cr2	Cb4	Cr4
D17	Cb1	Cr1	Cb3	Cr3	Cb5	Cr5
D18	Cb2	Cr2	Cb4	Cr4	Cb6	Cr6
D19	Cb3	Cr3	Cb5	Cr5	Cb7	Cr7
D20	Cb4	Cr4	Cb6	Cr6	Cb8	Cr8
D21	Cb5	Cr5	Cb7	Cr7	Cb9	Cr9
D22	Cb6	Cr6	Cb8	Cr8	Cb10	Cr10
D23	Cb7	Cr7	Cb9	Cr9	Cb11	Cr11
HSYNC	grounded	grounded	grounded	grounded	grounded	grounded
VSYNC	grounded	grounded	grounded	grounded	grounded	grounded
DE	grounded	grounded	grounded	grounded	grounded	grounded

Table 5. Mappings of 16/20/24-bit YCbCr422 with embedded syncs

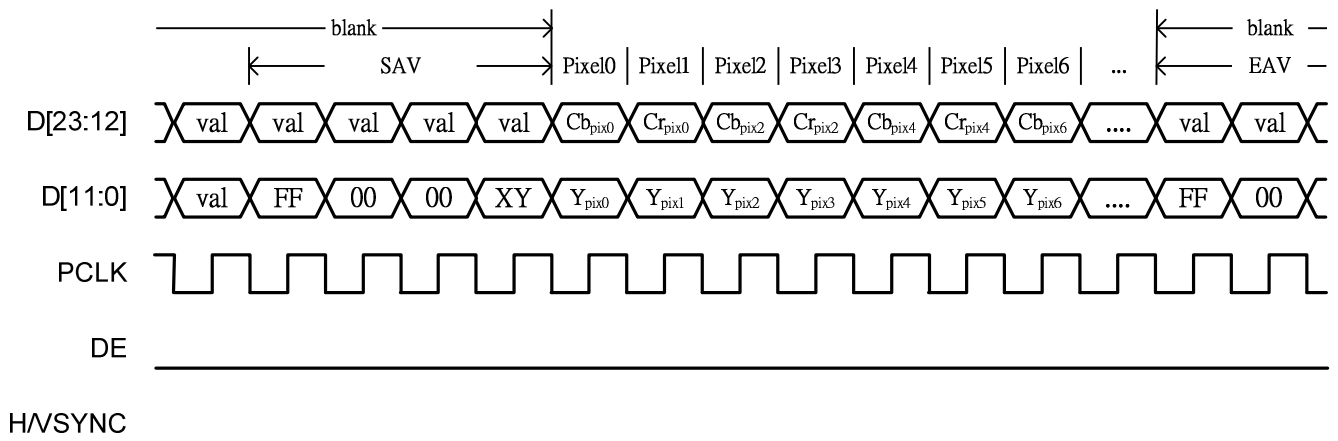

Figure 7. 16/20/24-bit YCbCr422 with embedded syncs

IT66121FN

Note:

1. FF, 00, 00, XY information are mapped to D[11:4]
2. 20-bit mode is compatible with BT1120 format 20-bit mode

IT66121FN

16/20/24-bit YCbCr422 with Embedded Syncs (BTA-T1004 Format)

The BTA-T1004 format is similar to the previous format except the SAV and EAV positions.

Pin Name	YCbCr 4:2:2 16-bit		YCbCr 4:2:2 20-bit		YCbCr 4:2:2 24-bit	
	Pixel#2N	Pixel#2N+1	Pixel#2N	Pixel#2N+1	Pixel#2N	Pixel#2N+1
D0	grounded	grounded	grounded	grounded	Y0	Y0
D1	grounded	grounded	grounded	grounded	Y1	Y1
D2	grounded	grounded	Y0	Y0	Y2	Y2
D3	grounded	grounded	Y1	Y1	Y3	Y3
D4	Y0	Y0	Y2	Y2	Y4	Y4
D5	Y1	Y1	Y3	Y3	Y5	Y5
D6	Y2	Y2	Y4	Y4	Y6	Y6
D7	Y3	Y3	Y5	Y5	Y7	Y7
D8	Y4	Y4	Y6	Y6	Y8	Y8
D9	Y5	Y5	Y7	Y7	Y9	Y9
D10	Y6	Y6	Y8	Y8	Y10	Y10
D11	Y7	Y7	Y9	Y9	Y11	Y11
D12	grounded	grounded	grounded	grounded	Cb0	Cr0
D13	grounded	grounded	grounded	grounded	Cb1	Cr1
D14	grounded	grounded	Cb0	Cr0	Cb2	Cr2
D15	grounded	grounded	Cb1	Cr1	Cb3	Cr3
D16	Cb0	Cr0	Cb2	Cr2	Cb4	Cr4
D17	Cb1	Cr1	Cb3	Cr3	Cb5	Cr5
D18	Cb2	Cr2	Cb4	Cr4	Cb6	Cr6
D19	Cb3	Cr3	Cb5	Cr5	Cb7	Cr7
D20	Cb4	Cr4	Cb6	Cr6	Cb8	Cr8
D21	Cb5	Cr5	Cb7	Cr7	Cb9	Cr9
D22	Cb6	Cr6	Cb8	Cr8	Cb10	Cr10
D23	Cb7	Cr7	Cb9	Cr9	Cb11	Cr11
HSYNC	grounded	grounded	grounded	grounded	grounded	grounded
VSYNC	grounded	grounded	grounded	grounded	grounded	grounded
DE	grounded	grounded	grounded	grounded	grounded	grounded

Table 6. Mappings of YCbCr422 with embedded syncs (BTA-T1004 format)

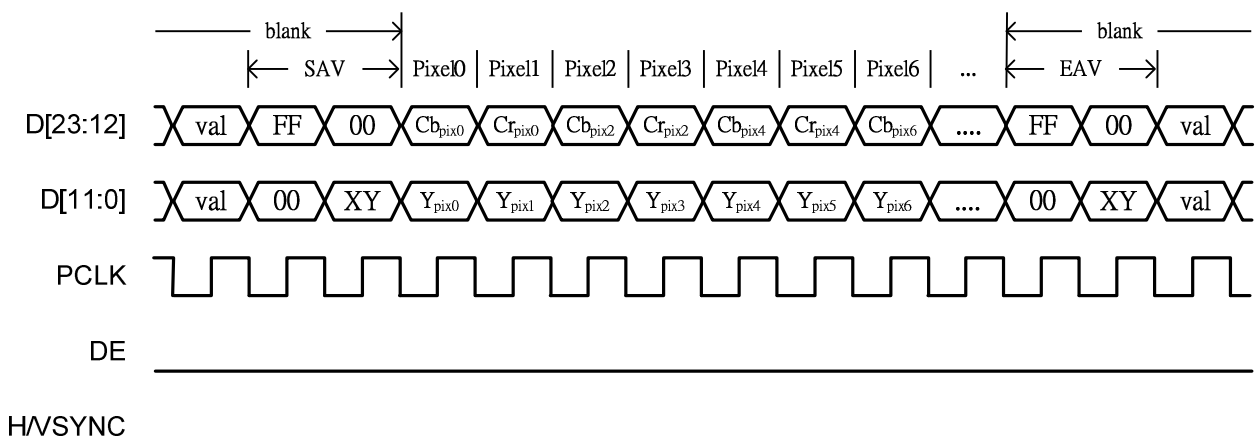

Figure 8. 16/20/24-bit YCbCr422 with embedded syncs (BTA-T1004 format)

Note:

1. FF, 00, 00, XY information are mapped to D[23:16] and D[11:4]

IT66121FN

8/10/12-bit YCbCr422 with Embedded Syncs

This format is another variation of the YCbCr formats. The bus width is further reduced by half compared from the previous YCbCr 4:2:2 formats, to either 8-bit, 10-bit or 12-bit. To compensate for the halving of data bus, PCLK is doubled. With the double-rate input clock, luminance channel (Y) and chroma channels (Cb or Cr) are alternated.

Pin Name	YCbCr 4:2:2 8-bit		YCbCr 4:2:2 10-bit		YCbCr 4:2:2 12-bit	
	1st PCLK	2nd PCLK	1st PCLK	2nd PCLK	Pixel#2N	Pixel#2N+1
D0	grounded	grounded	grounded	grounded	grounded	grounded
D1	grounded	grounded	grounded	grounded	grounded	grounded
D2	grounded	grounded	grounded	grounded	grounded	grounded
D3	grounded	grounded	grounded	grounded	grounded	grounded
D4	grounded	grounded	grounded	grounded	C0	Y0
D5	grounded	grounded	grounded	grounded	C1	Y1
D6	grounded	grounded	C0	Y0	C2	Y2
D7	grounded	grounded	C1	Y1	C3	Y3
D8	C0	Y0	C2	Y2	C4	Y4
D9	C1	Y1	C3	Y3	C5	Y5
D10	C2	Y2	C4	Y4	C6	Y6
D11	C3	Y3	C5	Y5	C7	Y7
D12	C4	Y4	C6	Y6	C8	Y9
D13	C5	Y5	C7	Y7	C9	Y9
D14	C6	Y6	C8	Y8	C10	Y10
D15	C7	Y7	C9	Y9	C11	Y11
D16	grounded	grounded	grounded	grounded	grounded	grounded
D17	grounded	grounded	grounded	grounded	grounded	grounded
D18	grounded	grounded	grounded	grounded	grounded	grounded
D19	grounded	grounded	grounded	grounded	grounded	grounded
D20	grounded	grounded	grounded	grounded	grounded	grounded
D21	grounded	grounded	grounded	grounded	grounded	grounded
D22	grounded	grounded	grounded	grounded	grounded	grounded
D23	grounded	grounded	grounded	grounded	grounded	grounded
HSYNC	grounded	grounded	grounded	grounded	grounded	grounded
VSYNC	grounded	grounded	grounded	grounded	grounded	grounded
DE	grounded	grounded	grounded	grounded	grounded	grounded

Table 7. Mappings of 8/10/12-bit YCbCr422 with embedded syncs

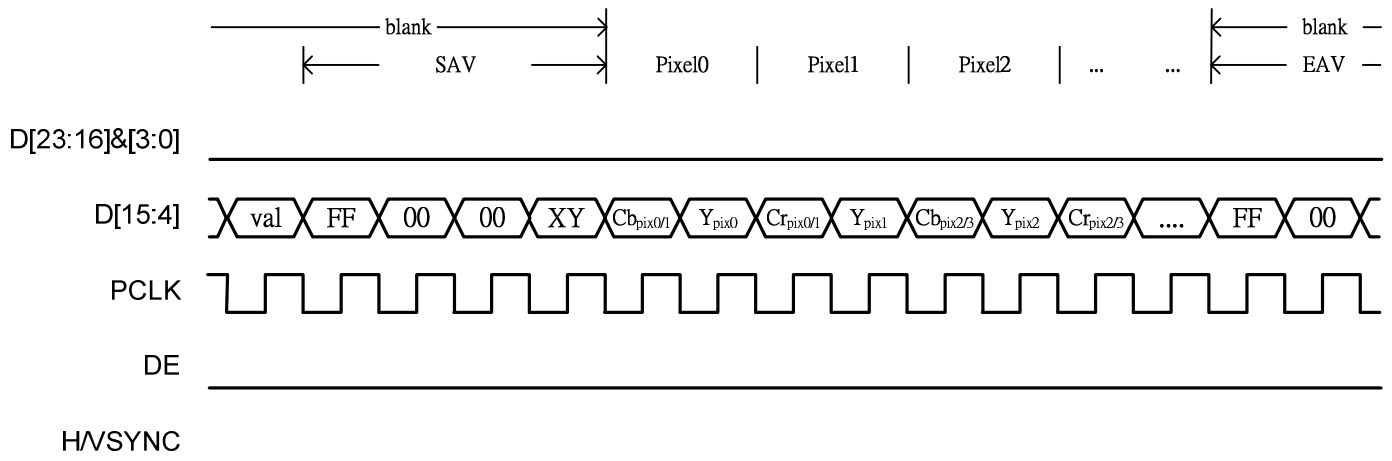

Figure 9. 8/10/12-bit YCbCr422 with embedded syncs

Note:

1. FF, 00, 00, XY information are mapped to D[15:8]
2. 8-bit mode is compatible with CCIR656 format
3. 10-bit mode is compatible with BT1120 format 10-bit mode

IT66121FN

8/10/12-bit YCbCr422 with Separate Syncs

This format is simply the variation of previously mentioned one plus separate syncs.

Pin Name	YCbCr 4:2:2 8-bit		YCbCr 4:2:2 10-bit		YCbCr 4:2:2 12-bit	
	1st PCLK	2nd PCLK	1st PCLK	2nd PCLK	Pixel#2N	Pixel#2N+1
D0	grounded	grounded	grounded	grounded	grounded	grounded
D1	grounded	grounded	grounded	grounded	grounded	grounded
D2	grounded	grounded	grounded	grounded	grounded	grounded
D3	grounded	grounded	grounded	grounded	grounded	grounded
D4	grounded	grounded	grounded	grounded	C0	Y0
D5	grounded	grounded	grounded	grounded	C1	Y1
D6	grounded	grounded	C0	Y0	C2	Y2
D7	grounded	grounded	C1	Y1	C3	Y3
D8	C0	Y0	C2	Y2	C4	Y4
D9	C1	Y1	C3	Y3	C5	Y5
D10	C2	Y2	C4	Y4	C6	Y6
D11	C3	Y3	C5	Y5	C7	Y7
D12	C4	Y4	C6	Y6	C8	Y9
D13	C5	Y5	C7	Y7	C9	Y9
D14	C6	Y6	C8	Y8	C10	Y10
D15	C7	Y7	C9	Y9	C11	Y11
D16	grounded	grounded	grounded	grounded	grounded	grounded
D17	grounded	grounded	grounded	grounded	grounded	grounded
D18	grounded	grounded	grounded	grounded	grounded	grounded
D19	grounded	grounded	grounded	grounded	grounded	grounded
D20	grounded	grounded	grounded	grounded	grounded	grounded
D21	grounded	grounded	grounded	grounded	grounded	grounded
D22	grounded	grounded	grounded	grounded	grounded	grounded
D23	grounded	grounded	grounded	grounded	grounded	grounded
HSYNC	HSYNC		HSYNC		HSYNC	
VSYNC	VSYNC		VSYNC		VSYNC	
DE	DE		DE		DE	

Table 8. Mappings of 8/10/12-bit YCbCr422 with separate syncs

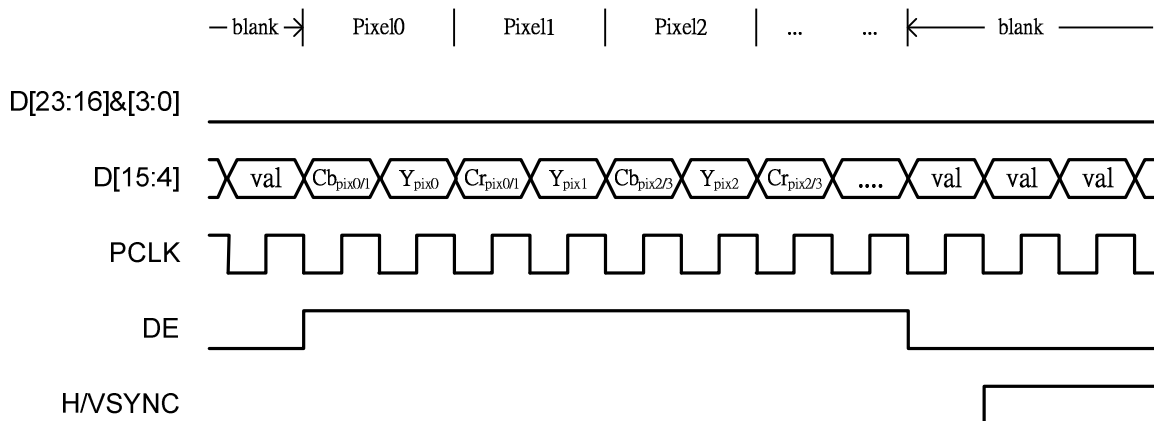

Figure 10. 8/10/12-bit YCbCr422 with separate syncs

IT66121FN

The IT66121 supports another IO mapping method of YCbCr 4:2:2 formats which we call Non-sequential IO Mode. The only difference between these two modes is the Y/Cb/Cr data mapping sequence of the IO pin. The following tables show the different mappings of these two modes.

- **Non-sequential IO mode of 16/20/24-bit YCbCr422**

Pin Name	YCbCr 4:2:2 16-bit		YCbCr 4:2:2 20-bit		YCbCr 4:2:2 24-bit	
	Pixel#2N	Pixel#2N+1	Pixel#2N	Pixel#2N+1	Pixel#2N	Pixel#2N+1
D0	grounded	grounded	grounded	grounded	Y0	Y0
D1	grounded	grounded	grounded	grounded	Y1	Y1
D2	grounded	grounded	Y0	Y0	Y2	Y2
D3	grounded	grounded	Y1	Y1	Y3	Y3
D4	grounded	grounded	grounded	grounded	Cb0	Cr0
D5	grounded	grounded	grounded	grounded	Cb1	Cr1
D6	grounded	grounded	Cb0	Cr0	Cb2	Cr2
D7	grounded	grounded	Cb1	Cr1	Cb3	Cr3
D8	Y0	Y0	Y2	Y2	Y4	Y4
D9	Y1	Y1	Y3	Y3	Y5	Y5
D10	Y2	Y2	Y4	Y4	Y6	Y6
D11	Y3	Y3	Y5	Y5	Y7	Y7
D12	Y4	Y4	Y6	Y6	Y8	Y8
D13	Y5	Y5	Y7	Y7	Y9	Y9
D14	Y6	Y6	Y8	Y8	Y10	Y10
D15	Y7	Y7	Y9	Y9	Y11	Y11
D16	Cb0	Cr0	Cb2	Cr2	Cb4	Cr4
D17	Cb1	Cr1	Cb3	Cr3	Cb5	Cr5
D18	Cb2	Cr2	Cb4	Cr4	Cb6	Cr6
D19	Cb3	Cr3	Cb5	Cr5	Cb7	Cr7
D20	Cb4	Cr4	Cb6	Cr6	Cb8	Cr8
D21	Cb5	Cr5	Cb7	Cr7	Cb9	Cr9
D22	Cb6	Cr6	Cb8	Cr8	Cb10	Cr10
D23	Cb7	Cr7	Cb9	Cr9	Cb11	Cr11
HSYNC	HSYNC	HSYNC	HSYNC	HSYNC	HSYNC	HSYNC
VSYNC	VSYNC	VSYNC	VSYNC	VSYNC	VSYNC	VSYNC
DE	DE	DE	DE	DE	DE	DE

Table 9. Mappings of 16/20/24-bit YCbCr422 non-sequential IO mode

IT66121FN

- **Non-sequential IO mode of 8/10/12-bit YCbCr422**

Pin Name	YCbCr 4:2:2 8-bit		YCbCr 4:2:2 10-bit		YCbCr 4:2:2 12-bit	
	1st PCLK	2nd PCLK	1st PCLK	2nd PCLK	Pixel#2N	Pixel#2N+1
D0	grounded	grounded	grounded	grounded	C0	Y0
D1	grounded	grounded	grounded	grounded	C1	Y1
D2	grounded	grounded	C0	Y0	C2	Y2
D3	grounded	grounded	C1	Y1	C3	Y3
D4	grounded	grounded	grounded	grounded	grounded	grounded
D5	grounded	grounded	grounded	grounded	grounded	grounded
D6	grounded	grounded	grounded	grounded	grounded	grounded
D7	grounded	grounded	grounded	grounded	grounded	grounded
D8	C0	Y0	C2	Y2	C4	Y4
D9	C1	Y1	C3	Y3	C5	Y5
D10	C2	Y2	C4	Y4	C6	Y6
D11	C3	Y3	C5	Y5	C7	Y7
D12	C4	Y4	C6	Y6	C8	Y9
D13	C5	Y5	C7	Y7	C9	Y9
D14	C6	Y6	C8	Y8	C10	Y10
D15	C7	Y7	C9	Y9	C11	Y11
D16	grounded	grounded	grounded	grounded	grounded	grounded
D17	grounded	grounded	grounded	grounded	grounded	grounded
D18	grounded	grounded	grounded	grounded	grounded	grounded
D19	grounded	grounded	grounded	grounded	grounded	grounded
D20	grounded	grounded	grounded	grounded	grounded	grounded
D21	grounded	grounded	grounded	grounded	grounded	grounded
D22	grounded	grounded	grounded	grounded	grounded	grounded
D23	grounded	grounded	grounded	grounded	grounded	grounded
HSYNC	grounded	grounded	grounded	grounded	grounded	grounded
VSYNC	grounded	grounded	grounded	grounded	grounded	grounded
DE	grounded	grounded	grounded	grounded	grounded	grounded

Table 10. Mappings of 8/10/12-bit YCbCr422 non-sequential IO mode

In additional to the previous input formats, there are three options can be supported by the IT66121. DE-only option can be used for those input formats without H/VSync information. Dual-edge triggering with half bus width option can be used to reduce the necessary bus width and dual-edge triggering with half pixel clock option allows half input pixel clock. No all the input formats listed above can support three options and please refer to the IT66121 programming guide for more information. Some examples shown below are the corresponding timing relations when these options are enabled.

IT66121FN

DE-Only Option: use 24-bit RGB/YCbCr444 (DE-only mode) as example

Pin Name	RGB	YCbCr
D0	B0	Cb0
D1	B1	Cb1
D2	B2	Cb2
D3	B3	Cb3
D4	B4	Cb4
D5	B5	Cb5
D6	B6	Cb6
D7	B7	Cb7
D8	G0	Y0
D9	G1	Y1
D10	G2	Y2
D11	G3	Y3
D12	G4	Y4
D13	G5	Y5
D14	G6	Y6
D15	G7	Y7
D16	R0	Cr0
D17	R1	Cr1
D18	R2	Cr2
D19	R3	Cr3
D20	R4	Cr4
D21	R5	Cr5
D22	R6	Cr6
D23	R7	Cr7
HSYNC	grounded	grounded
VSYNC	grounded	grounded
DE	DE	DE

Table 11. Mappings of 24-bit RGB/YCbCr444 (DE-only mode)

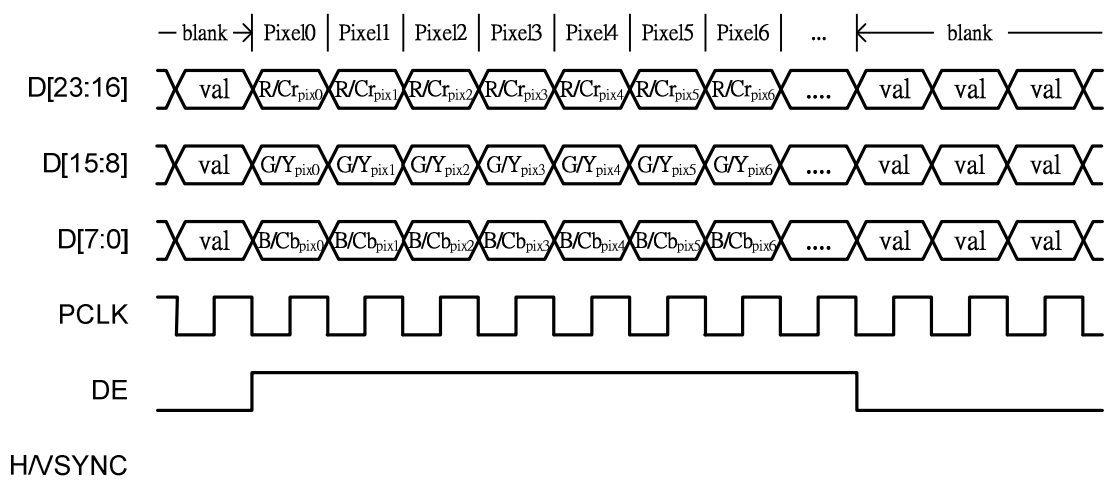

Figure 11. 24-bit RGB/YCbCr444 (DE-only mode)

IT66121FN

Dual-Edge Triggering with Half Bus Width: use 12-bit RGB/YCbCr444 format as example

Pin Name	RGB		YCbCr	
	1st edge	2nd edge	1st edge	2nd edge
D0	B0	G4	Cb0	Y4
D1	B1	G5	Cb1	Y5
D2	B2	G6	Cb2	Y6
D3	B3	G7	Cb3	Y7
D4	B4	R0	Cb4	Cr0
D5	B5	R1	Cb5	Cr1
D6	B6	R2	Cb6	Cr2
D7	B7	R3	Cb7	Cr3
D8	G0	R4	Y0	Cr4
D9	G1	R5	Y1	Cr5
D10	G2	R6	Y2	Cr6
D11	G3	R7	Y3	Cr7
D12	grounded	grounded	grounded	grounded
D13	grounded	grounded	grounded	grounded
D14	grounded	grounded	grounded	grounded
D15	grounded	grounded	grounded	grounded
D16	grounded	grounded	grounded	grounded
D17	grounded	grounded	grounded	grounded
D18	grounded	grounded	grounded	grounded
D19	grounded	grounded	grounded	grounded
D20	grounded	grounded	grounded	grounded
D21	grounded	grounded	grounded	grounded
D22	grounded	grounded	grounded	grounded
D23	grounded	grounded	grounded	grounded
HSYNC	HSYNC		HSYNC	
VSYNC	VSYNC		VSYNC	
DE	DE		DE	

Table 12. Mappings of 12-bit RGB/YCbCr444 dual-edge triggering (separate syncs)

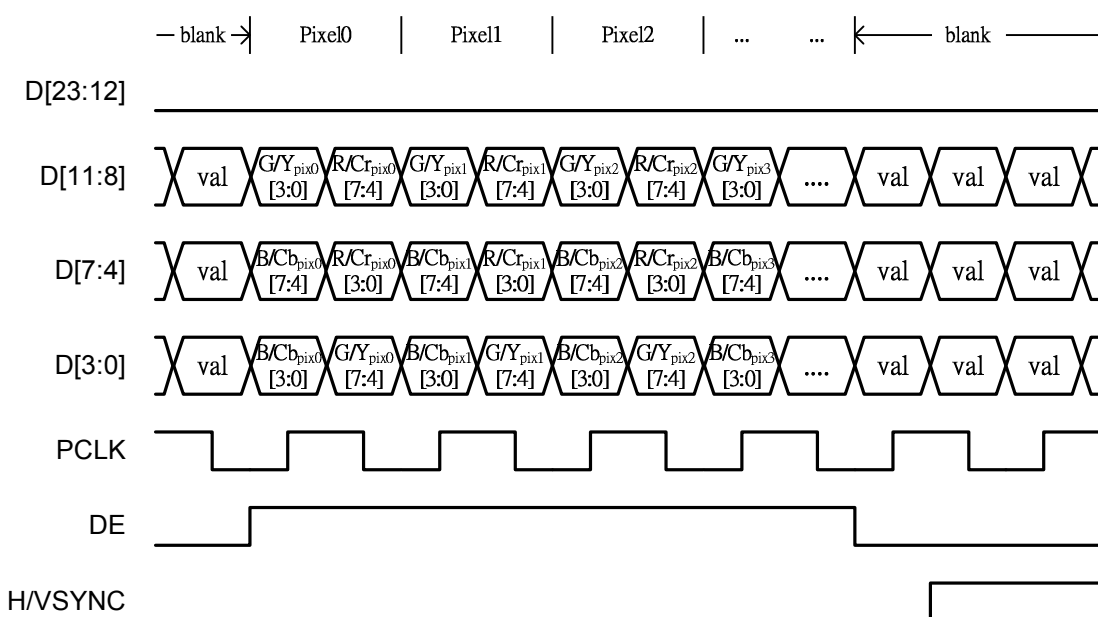

Figure 12. 12-bit RGB/YCbCr444 dual-edge triggering (separate syncs)

Dual-Edge Triggering with Half Pixel Clock:

Example 1: 24-bit RGB/YCbCr444 with Separate Syncs and Dual-Edge Triggering

Pin Name	RGB	YCbCr
D0	B0	Cb0
D1	B1	Cb1
D2	B2	Cb2
D3	B3	Cb3
D4	B4	Cb4
D5	B5	Cb5
D6	B6	Cb6
D7	B7	Cb7
D8	G0	Y0
D9	G1	Y1
D10	G2	Y2
D11	G3	Y3
D12	G4	Y4
D13	G5	Y5
D14	G6	Y6
D15	G7	Y7
D16	R0	Cr0
D17	R1	Cr1
D18	R2	Cr2
D19	R3	Cr3
D20	R4	Cr4
D21	R5	Cr5
D22	R6	Cr6
D23	R7	Cr7
HSYNC	HSYNC	HSYNC
VSYNC	VSYNC	VSYNC
DE	DE	DE

Table 13. Mappings of 24-bit RGB/YCbCr444 dual-edge triggering (separate syncs)

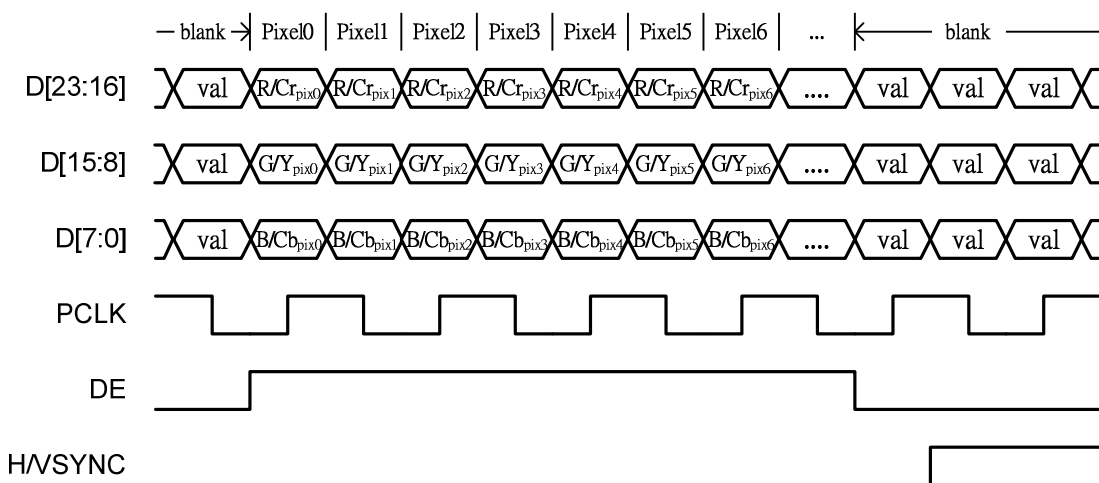

Figure 13. 24-bit RGB/YCbCr444 dual-edge triggering (separate syncs)

Example 2: 16/20/24-bit YCbCr422 with Separate Syncs using Dual-Edge Triggering

Pin Name	YCbCr 4:2:2 16-bit		YCbCr 4:2:2 20-bit		YCbCr 4:2:2 24-bit	
	1st edge	2nd edge	1st edge	2nd edge	1st edge	2nd edge
D0	grounded	grounded	grounded	grounded	Y0	Y0
D1	grounded	grounded	grounded	grounded	Y1	Y1
D2	grounded	grounded	Y0	Y0	Y2	Y2
D3	grounded	grounded	Y1	Y1	Y3	Y3
D4	Y0	Y0	Y2	Y2	Y4	Y4
D5	Y1	Y1	Y3	Y3	Y5	Y5
D6	Y2	Y2	Y4	Y4	Y6	Y6
D7	Y3	Y3	Y5	Y5	Y7	Y7
D8	Y4	Y4	Y6	Y6	Y8	Y8
D9	Y5	Y5	Y7	Y7	Y9	Y9
D10	Y6	Y6	Y8	Y8	Y10	Y10
D11	Y7	Y7	Y9	Y9	Y11	Y11
D12	grounded	grounded	grounded	grounded	Cb0	Cr0
D13	grounded	grounded	grounded	grounded	Cb1	Cr1
D14	grounded	grounded	Cb0	Cr0	Cb2	Cr2
D15	grounded	grounded	Cb1	Cr1	Cb3	Cr3
D16	Cb0	Cr0	Cb2	Cr2	Cb4	Cr4
D17	Cb1	Cr1	Cb3	Cr3	Cb5	Cr5
D18	Cb2	Cr2	Cb4	Cr4	Cb6	Cr6
D19	Cb3	Cr3	Cb5	Cr5	Cb7	Cr7
D20	Cb4	Cr4	Cb6	Cr6	Cb8	Cr8
D21	Cb5	Cr5	Cb7	Cr7	Cb9	Cr9
D22	Cb6	Cr6	Cb8	Cr8	Cb10	Cr10
D23	Cb7	Cr7	Cb9	Cr9	Cb11	Cr11
HSYNC	HSYNC	HSYNC	HSYNC	HSYNC	HSYNC	HSYNC
VSYNC	VSYNC	VSYNC	VSYNC	VSYNC	VSYNC	VSYNC
DE	DE	DE	DE	DE	DE	DE

Table 14. Mappings of 16/20/24-bit YCbCr422 dual-edge triggering (separate syncs)

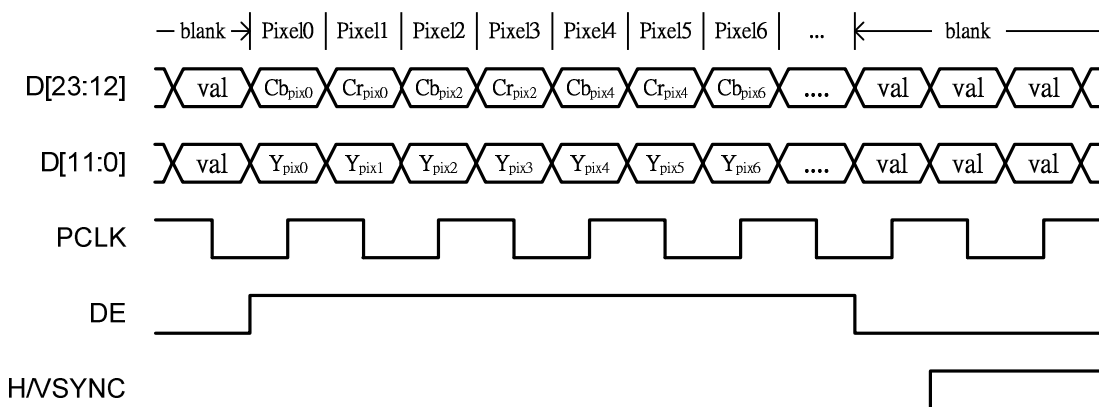

Figure 14. 16/20/24-bit YCbCr422 dual-edge triggering (separate syncs)

Example 3: 8/10/12-bit YCbCr422 with Embedded Syncs using Dual-Edge Triggering

Pin Name	YCbCr 4:2:2 8-bit		YCbCr 4:2:2 10-bit		YCbCr 4:2:2 12-bit	
	1st edge	2nd edge	1st edge	2nd edge	1st edge	2nd edge
D0	grounded	grounded	grounded	grounded	grounded	grounded
D1	grounded	grounded	grounded	grounded	grounded	grounded
D2	grounded	grounded	grounded	grounded	grounded	grounded
D3	grounded	grounded	grounded	grounded	grounded	grounded
D4	grounded	grounded	grounded	grounded	C0	Y0
D5	grounded	grounded	grounded	grounded	C1	Y1
D6	grounded	grounded	C0	Y0	C2	Y2
D7	grounded	grounded	C1	Y1	C3	Y3
D8	C0	Y0	C2	Y2	C4	Y4
D9	C1	Y1	C3	Y3	C5	Y5
D10	C2	Y2	C4	Y4	C6	Y6
D11	C3	Y3	C5	Y5	C7	Y7
D12	C4	Y4	C6	Y6	C8	Y9
D13	C5	Y5	C7	Y7	C9	Y9
D14	C6	Y6	C8	Y8	C10	Y10
D15	C7	Y7	C9	Y9	C11	Y11
D16	grounded	grounded	grounded	grounded	grounded	grounded
D17	grounded	grounded	grounded	grounded	grounded	grounded
D18	grounded	grounded	grounded	grounded	grounded	grounded
D19	grounded	grounded	grounded	grounded	grounded	grounded
D20	grounded	grounded	grounded	grounded	grounded	grounded
D21	grounded	grounded	grounded	grounded	grounded	grounded
D22	grounded	grounded	grounded	grounded	grounded	grounded
D23	grounded	grounded	grounded	grounded	grounded	grounded
HSYNC	grounded	grounded	grounded	grounded	grounded	grounded
VSYNC	grounded	grounded	grounded	grounded	grounded	grounded
DE	grounded	grounded	grounded	grounded	grounded	grounded

Table 15. Mappings of 8/10/12-bit YCbCr422 dual-edge triggering (embedded syncs)

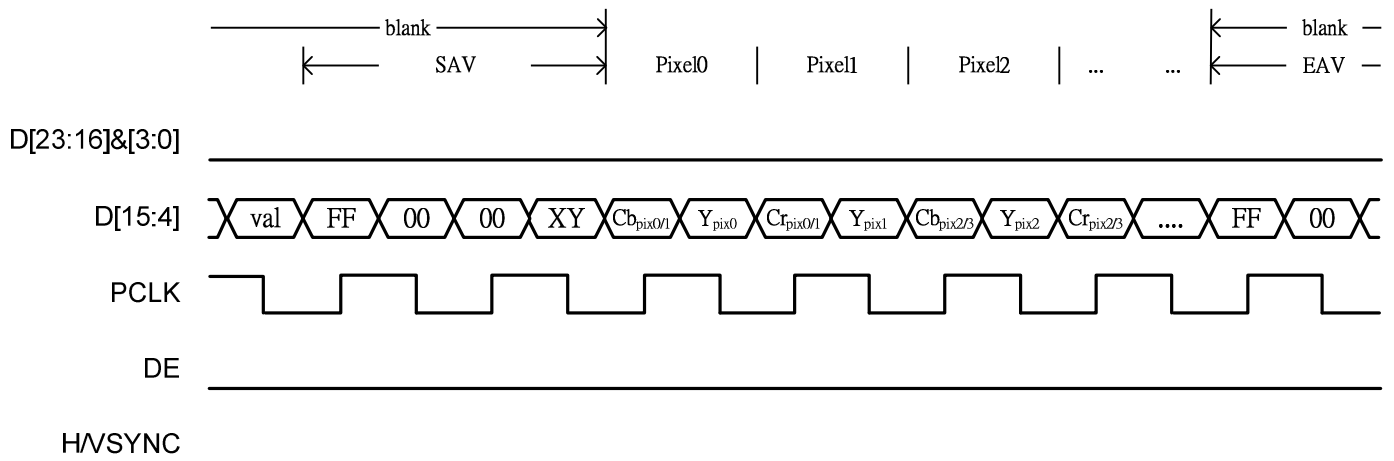

Figure 15. 8/10/12-bit YCbCr422 dual-edge triggering (embedded syncs)

System Design Consideration

As a high-performance receiver/transmitter, ITE's RX/TX is capable of receiving/transmitting those signals that are attenuated and degraded by the HDMI cables. These signals are usually very small in amplitudes in addition to the distortion that the cable inflicts on them. The analog front-end of ITE's RX/TX is designed to combat environment noises as well as interference to some degree. However, to get the optimum performance the system designers should follow the guideline below when designing the application circuits and PCB layout.

● HDMI Differential Signal

The characteristic impedance of all differential PCB traces (RX2P/M, RX1P/M, RX0P/M, and RXCP/M) should be kept 100_ all the way from the HDMI connector to ITE's RX/TX. This is very crucial to the system performance at high speeds. When routing these 4 differential transmission lines (8 single-ended lines in total), the following guidelines should be followed:

1. The signals traces should be on the outside layers (e.g. TOP layer) while beneath it there should be a continuous ground plane in order to maintain the called micro-strip structure, giving stable and well-defined characteristic impedances.
2. Cornering, through holes, crossing and any irregular signal routing should be avoided so as to prevent from disrupting the EM field and creating discontinuity in characteristic impedance.
3. ITE's RX/TX should be placed as close to the HDMI connector as possible. Since the TMDS signal pins of ITE's RX/TX perfectly match the order of the connector pins, it is very convenient to route the signal directly into the chip, without through holes or angling.
4. Carefully choose the width and spacing of the differential transmission lines as their characteristic impedance depends on various parameters of the PCB: trace width, trace spacing, copper thickness, dielectric constant, dielectric thickness, etc. Careful 3D EM simulation is the best way to derive a correct dimension that enables nominal 100_ differential impedance. Please contact us directly for technical support of this issue.
5. The sensitive HDMI differential signals should be taken when routing. To reduce the differential unbalanced effect, it is recommended to separate at least **3 times** the dielectric thickness between the signal layer and the reference layer to any other adjacent signal or GND plane to reduce noise inference and jitter. (or 25 mils is enough space in almost PCB stack)

● ESD Consideration

Special care should be taken when adding discrete ESD devices to all differential PCB traces (RX2P/M, RX1P/M, RX0P/M, and RXCP/M). ITE's RX/TX is designed to provide ESD protection for up to 2kV at these pins. Adding discrete ESD diodes could enhance the ESD capability, but at the same time will inevitably add capacitive loads, therefore degrade the electrical performance at

IT66121FN

high speeds. If not chosen carefully, these diodes coupled with less-than-optimal layout would prevent the system from passing the SINK TMDs-Differential Impedance test in the HDMI Compliance Test (Test ID 8-8). Besides, most general-purpose ESD diodes are relatively large in size, forcing the high-speed differential lines to corner several times and therefore introducing severe reflection. Carefully choosing an ESD diode that's designed for HDMI signaling could lead to a minimum loading as well as an optimized layout. Commercially available devices such as Semtech's RClamp0524p that take into consideration of all aspects are recommended. A layout example is shown in Fig. 16, with referenced FR4 PCB structure included. Note that the ESD diodes should be placed as close to the HDMI connectors as possible to yield the best ESD performances.

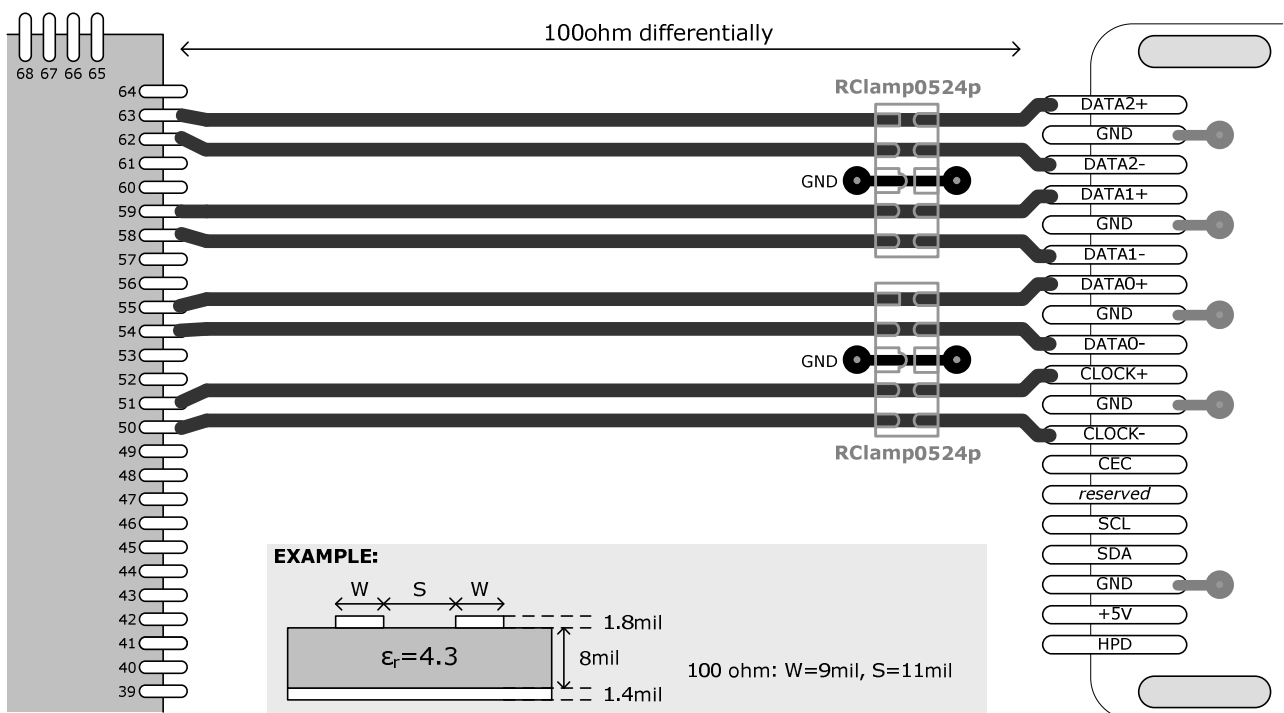
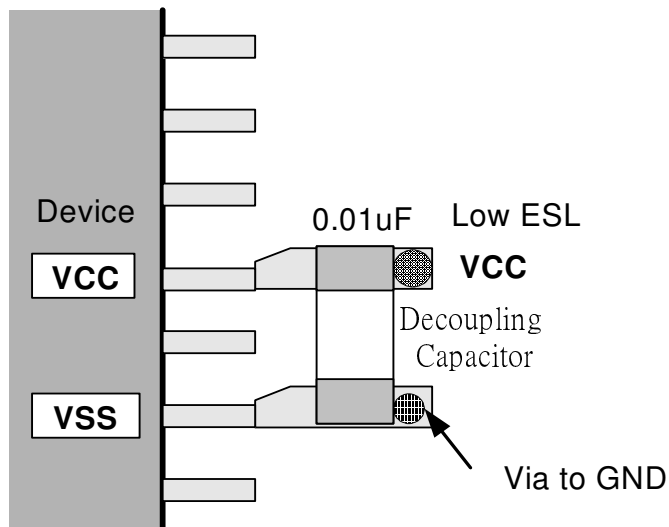

Figure 16: PCB layout example for high-speed transmission lines with RClamp0524p

Notes: The PCB stack and material will affect differential impedance. The customer shall co-work with PCB provider to obtain the real 100 ohm impedance based on actual PCB stack and material.

● Power Supply Bypassing

1. It is recommended to bypass each group of power supply pin with a 0.1μF capacitor.
2. It is also recommended that the bypass capacitor be located within about 0.5cm distance of each power pin.



3. Avoid placing the capacitor on the opposite side of the PC board from the HDMI IC.
4. It is recommended to add ferrite beads for analog powers. Ex. PVDD, PVCC, AVDD etc...
5. Shorter power loop makes better performance.

- **High Speed Digital Input/Output Signals(Both Data and Clocks)**

1. To obtain good signal quality and avoid EMI issue, 4-layres PCB stacks are recommended.
2. Try to minimize the trace length that the digital outputs have to drive.
3. Keep these high speed signals refer to a continue GND or power plane, no GND or power slot break the returning current path.
4. It's recommended to add a series resistor of value 33 ohm to suppress reflections, reduce EMI, and reduce the current spikes. These series resistors should be place as close to the driving pins as possible.
5. If possible, try to place ITE's RX/TX and related "Scalar IC" on the same PCB side and route these high speed signals not to through vias to get the better signal quality.
6. The sensitive clock (PCLK) signals should be taken when routing. To reduce the crosstalk effect, it is recommended to separate at least 2 **times** the maximum dielectric thickness between the signal layer and the reference layer to any other adjacent signal to reduce noise inference and jitter.

IT66121FN

Package Dimensions

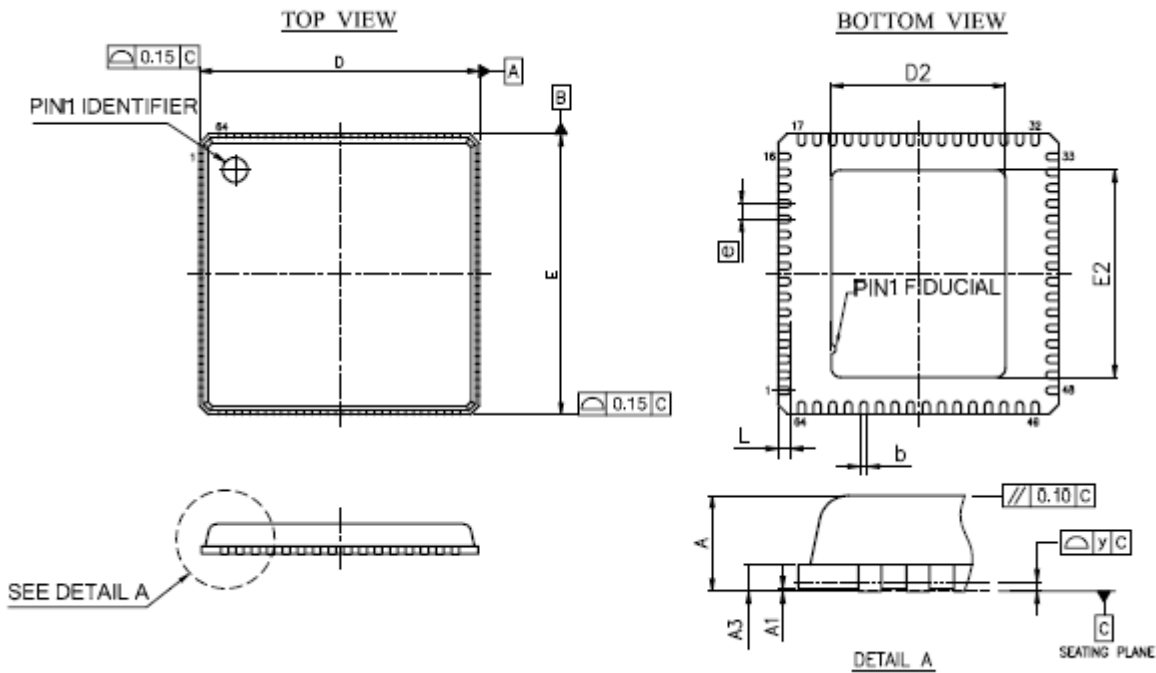

Symbol	Dimensions in inches			Dimensions in mm		
	Min.	Nom.	Max.	Min.	Nom.	Max.
A	0.031	0.035	0.039	0.80	0.90	1.00
A1	0.000	0.001	0.002	0.00	0.02	0.05
A3	0.008 REF			0.20 REF		
b	0.007	0.010	0.012	0.18	0.25	0.30
D	0.350	0.354	0.358	8.90	9.00	9.10
D2	0.141	0.149	0.157	3.58	3.78	3.98
E	0.350	0.354	0.358	8.90	9.00	9.10
E2	0.141	0.149	0.157	3.58	3.78	3.98
e	0.020 BSC			0.50 BSC		
L	0.012	0.016	0.020	0.30	0.40	0.50
y	--	--	0.003	--	--	0.08

Figure 17. 64-pin QFN Package Dimensions