

# KA9259D(KA9259HD)

## 5-Channel Motor Drive IC

### Features

- 4-CH Balanced Transformerless(BTL) Driver
- 1-CH (Forward/Reverse) DC Motor Driver With Speed Control Circuit
- Built-in TSD (Thermal Shutdown) Circuit
- Built-in 5V Regulator (With an External PNP Transistor)
- Built-in Mute Circuit
- Wide Operating Supply Voltage Range: 6V~13.2V

### Description

The KA9259D is a monolithic integrated circuit, and suitable for 5-CH motor driver which drives focus actuator, tracking actuator, sled motor, spindle motor and loading motor of compact disk player system.

28-SSOPH-375



### Typical Applications

- Compact Disk Player (CDP)
- Video Compact Disk Player (VCD)
- Automotive Compact Disk Player (CDP)
- Other Compact Disk Media

### Ordering Information

Device	Package	Operating Temp.
KA9259HD	28-SSOPH-375	-25°C ~ +75°C
KA9259HDTF	28-SSOPH-375	-25°C ~ +75°C

## Pin Assignments

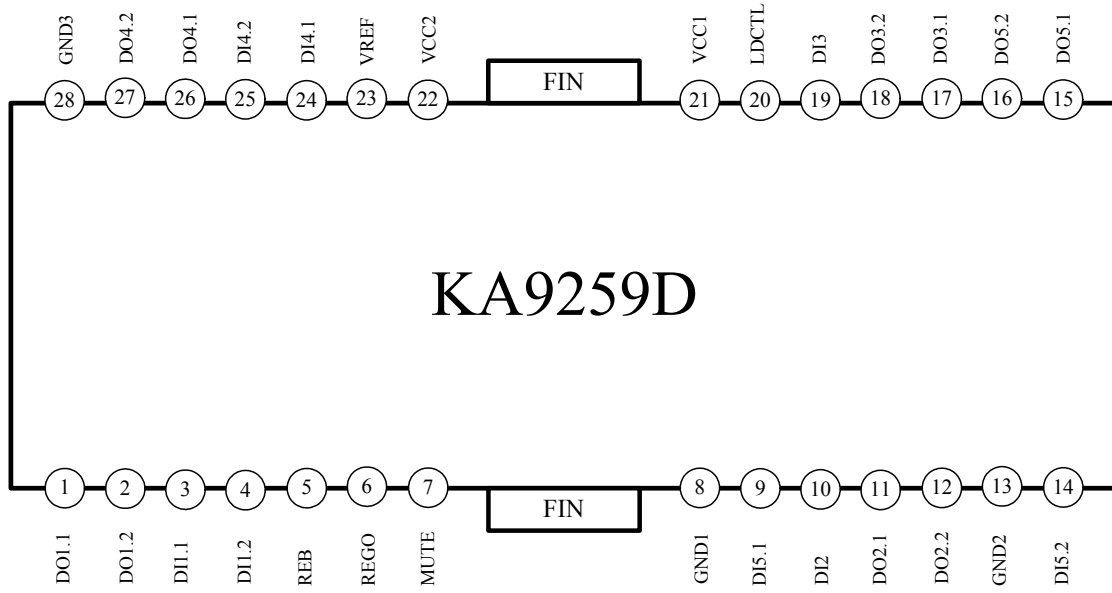

## Pin Definitions

Pin Number	Pin Name	I/O	Pin Function Description
1	DO1.1	O	Channel 1 output 1
2	DO1.2	O	Channel 1 output 2
3	DI1.1	I	Channel 1 input 1
4	DI1.2	I	Channel 1 input 2 (Adjustable)
5	REB	O	External transistor base drive output
6	REO	O	Regulator output
7	MUTE	I	Mute signal input
8	GND1	-	Ground 1
9	DI5.1	I	Channel 5 input 1 (Loading Motor)
10	DI2	I	Channel 2 input
11	DO2.1	O	Channel 2 output 1
12	DO2.2	O	Channel 2 output 2
13	GND2	-	Ground 2
14	DI5.2	I	Channel 5 input 2 (Loading Motor)
15	DO5.1	O	Channel 5 output 1 (Loading Motor)
16	DO5.2	O	Channel 5 output 2 (Loading Motor)
17	DO3.1	O	Channel 3 output 1
18	DO3.2	O	Channel 3 output 2
19	DI3	I	Channel 3 input
20	LD CTL	I	Channel 5 (Loading Motor) speed control input
21	VCC1	-	Power supply voltage 1
22	VCC2	-	Power supply voltage 2
23	VREF	I	Bias voltage input
24	DI4.1	I	Channel 4 input 1 (Adjustable)
25	DI4.2	I	Channel 4 input 2
26	DO4.1	O	Channel 3 output 1
27	DO4.2	O	Channel 3 output 2
28	GND3	-	Ground 3

# Internal Block Diagram

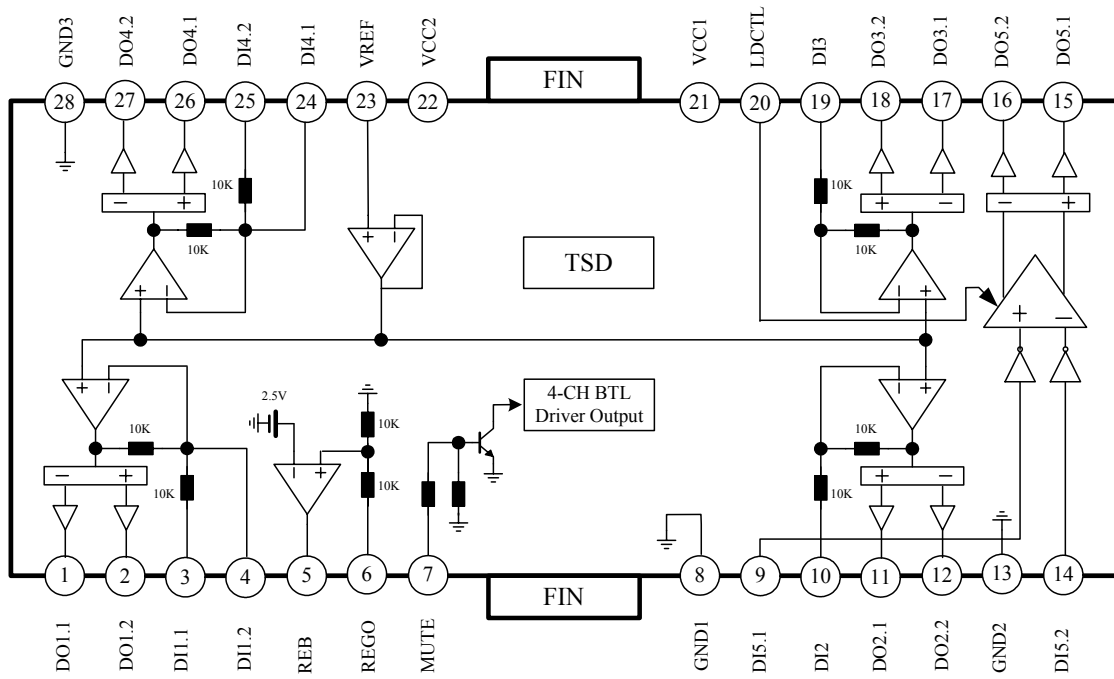

# Equivalent Circuits

Driver Input (Except For Loading Motor Driver)	Driver Output
Loading Motor Driver Input	Loading Motor Speed Control Input
Mute Input	Bias Input

## Absolute Maximum Ratings (Ta = 25°C)

Parameter	Symbol	Value	Unit
Maximum Supply Voltage	VCCMAX	15	V
Power Dissipation	PD	1.7 <sup>note</sup>	W
Operating Temperature	TOPR	-25 ~ +75	°C
Storage Temperature	TSTG	-55 ~ +150	°C
Maximum Current Output	IOMAX	1	A

### Note:

1. When mounted on 76mm × 114mm × 1.57mm PCB (Phenolic resin material).
2. Power dissipation reduces 13.6mW / °C for using above Ta=25°C
3. Do not exceed Pd and SOA.

## Power Dissipation Curve

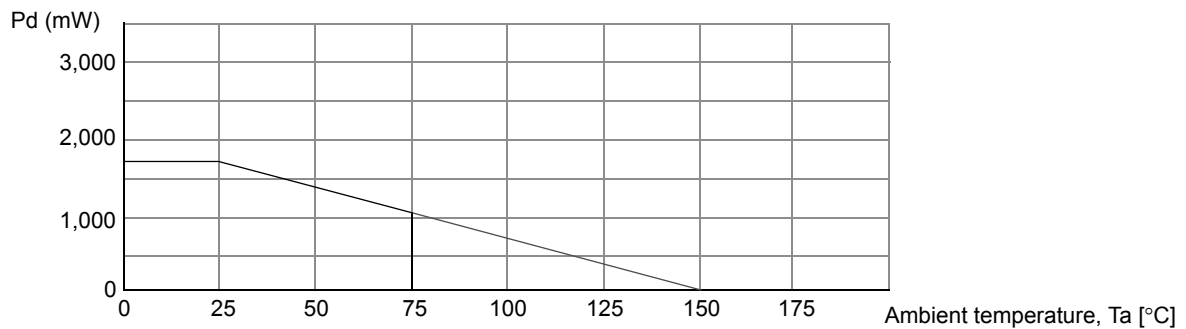

## Recommended Operating Condition (Ta = 25°C)

Parameter	Symbol	Value	Unit
Operating Supply Voltage	VCC	6 ~ 13.2	V

## Electrical Characteristics

(Ta = 25°C, VCC = 8V, RL = 8Ω, f = 1kHz, unless otherwise specified)

Parameter	Symbol	Conditions	Min.	Typ.	Max.	Unit
Quiescent Circuit Current	ICCQ	Under no-load	2.5	6	10	mA
Mute-on Current	IMUTE	Pin 7=GND	-	2.5	5	mA
Mute-on Voltage	VMON	-	-	-	0.5	V
Mute-off Voltage	VMOFF	-	2	-	-	V
<b>REGULATOR PART</b>						
Output Voltage	VREG	IL=100mA	4.7	5.0	5.3	V
Load Regulation	ΔVRL3	IL=0→200mA	-50	0	50	mV
Line Regulation	ΔVCC	VCC=6→13V, IL=100mA	-20	0	80	mV
<b>BTL DRIVER PART (CH1, CH2, CH3 and CH4)</b>						
Input Offset Voltage	VIO	-	-15	-	15	mV
Output Offset Voltage 1	VOO1	-	-40	-	40	mV
Maximum Source Current 1	ISOURCE1	RL=8Ω→VCC	0.25	0.4	-	A
Maximum Sink Current 1	ISINK1	RL=8Ω→GND	0.25	0.4	-	A
Maximum Output Voltage 3	VOM3	VIN=0.7V, VCC=13V	2.5	3.3	4.6	V
Maximum Output Voltage 4	VOM4	VIN=7V, VCC=13V, VIN=8V	-	-5.8	-5.0	V
Closed-Loop Voltage Gain	AVF	VIN=8V, VCC=13V	5	6.5	8	dB
Ripple Rejection Ratio (Note1)	RR	VIN=0.1VRMS, f=120Hz	40	60	-	dB
Slew Rate (Note1)	SR	120Hz, VIN=1VRMS, Square wave	1	2	-	V/μs
<b>LOADING MOTOR DRIVER PART (UNLESS OTHERWISE SPECIFIED, VCTL=OPENED)</b>						
Output Voltage 1	VO1	VPIN9=5V, VPIN14=0V, RL=45Ω	2.5	3.1	3.8	V
Output Voltage 2	VO2	VPIN9=0V, VPIN14=5V, RL=45Ω	2.5	3.1	3.8	V
Output Voltage Regulation 1 (CTL)	VOCTL1	VCTL=3.5→4.5V, VPIN9=5V, VPIN14=0V, RL=45Ω	0.5	1.0	1.5	V
Output Voltage Regulation 2 (CTL)	VOCTL2	VCTL=3.5→4.5V, VPIN9=0V, VPIN14=5V, RL=45Ω	0.5	1.0	1.5	V
Load Regulation 1	ΔVRL1	IL=100→400mA, VPIN9=5V, VPIN14=0V	-	300	700	mV
Load Regulation 2	ΔVRL2	IL=100→400mA, VPIN9=0V, VPIN14=5V	-	300	700	mV
Output Offset Voltage 2	VOO2	VPIN9=5V, VPIN14=5V	-40	-	40	mV
Output Offset Voltage 3	VOO3	VPIN9=0V, VPIN14=0V	-40	-	40	mV

### Note :

1. Guaranteed design value

# Application Information

## 1. Mute Function

Pin #7	Mute circuit
High	Mute-off
Low	Mute-on
Open	Mute-on

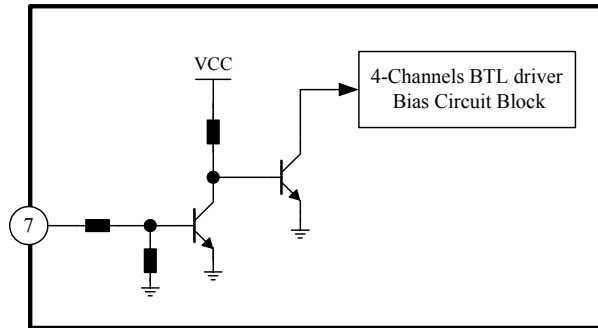

- When the mute (pin 7) is high level, the bias circuit of BTL driver is activated. On the other hand, when the mute (pin7) is open or low level, the bias circuit of BTL driver is disabled. So that the 4-channels BTL driver output circuit will be muted.

## 2. TSD (Thermal Shutdown) Function

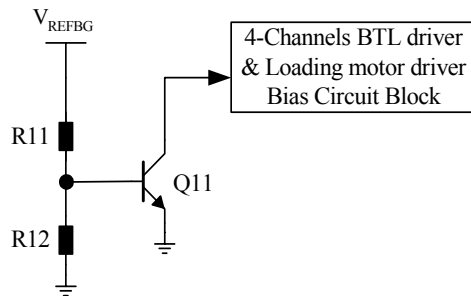

- The VREFBG is the output voltage of the band-gap-referenced biasing circuit and acts as the input voltage of the TSD circuit.
- The base-emitter voltage of the transistor, Q11 is designed to turn-on at below voltage.

$$V_{BE} = \frac{V_{REFBG} \times R12}{R11 + R12} = 400[mV]$$

- If the chip temperature rises above 175°C, then the TSD circuit is activated and the output circuit is muted. The TSD circuit has the hysteresis temperature of 25°C.

## 3. Voltage Regulator

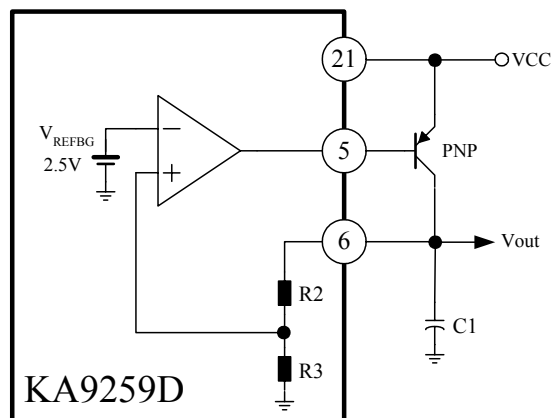



- The  $V_{REFBG}$  is the output voltage of the band-gap-referenced biasing circuit and is the reference voltage of the regulator.
- The external circuit is composed of the transistor(PNP), KSB772 and a capacitor(C1),  $100\mu\text{F}$ , and the capacitor is used as a ripple eliminator and should have a good temperature characteristics.
- The output voltage,  $V_{OUT}$  is decided as follows.

$$V_{OUT} = \left(1 + \frac{R2}{R3}\right)V_{REFBG} = 2 \times 2.5 = 5[V]$$

Where,  $R2 = R3$

## 4. Loading Motor Driver

### 4.1 Truth table and Operation

INPUT		OUTPUT		
PIN9(DI5.1)	PIN14(DI5.2)	PIN15(DO5.1)	PIN16 (DO5.2)	State
L	L	L	L	Brake
H	L	H	L	Forward
L	H	L	H	Reverse
H	H	L	L	Brake

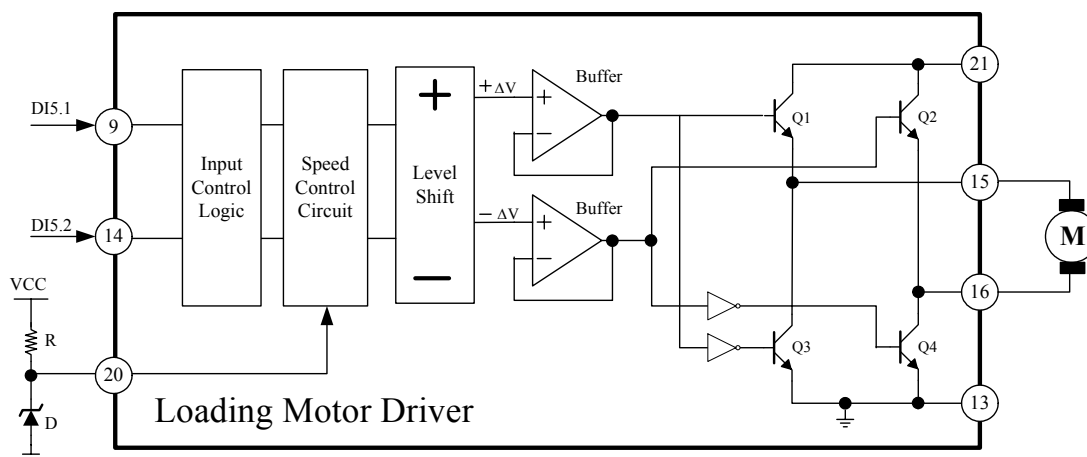

- The input voltages of (5V and 0V) or (0V and 5V) pairs are applied to the input pin #9 and #14 respectively.
- When the input voltages are applied to the input pin #9 and #14, then the output of the comparator is decided depends on the input voltage status.
- As shown in the above diagram, the difference voltage,  $\Delta V$ , is applied to the both terminals of the motor. The direction of the motor is decided by the voltage difference,  $+\Delta V$  and  $-\Delta V$ .
- The output characteristics is as follows,
  - If pin # 9=5V and #14=0V, then pin # 15=+ $\Delta V$  and #16= - $\Delta V$ , hence the motor turn in forward direction.
  - If pin # 9=0V and #14=5V, then pin # 15= - $\Delta V$  and #16=+ $\Delta V$ , hence the motor turn in reverse direction.
  - If pin # 9=5V and #14=5V, then  $\Delta V=0V$ , hence the motor stop.
  - If pin # 9=0V and #14=0V, then  $\Delta V=0V$ , hence the motor stop.

### 4.2 Loading Motor Speed Control

- If the torque of the loading motor is too low when it is used with the pin #20 open, then it should used as the above diagram.
- The desired torque could be obtained by selecting the appropriate resistor R as shown in the left diagram.
- If it is necessary, the zener diode can be used as in the right diagram.
- The maximum torque is obtained when the applied voltage at pin #20 is about 6.8V (at  $V_{CC}=8V$ ).

## 6. BTL Driver (CH1, CH2, CH3 and CH4)

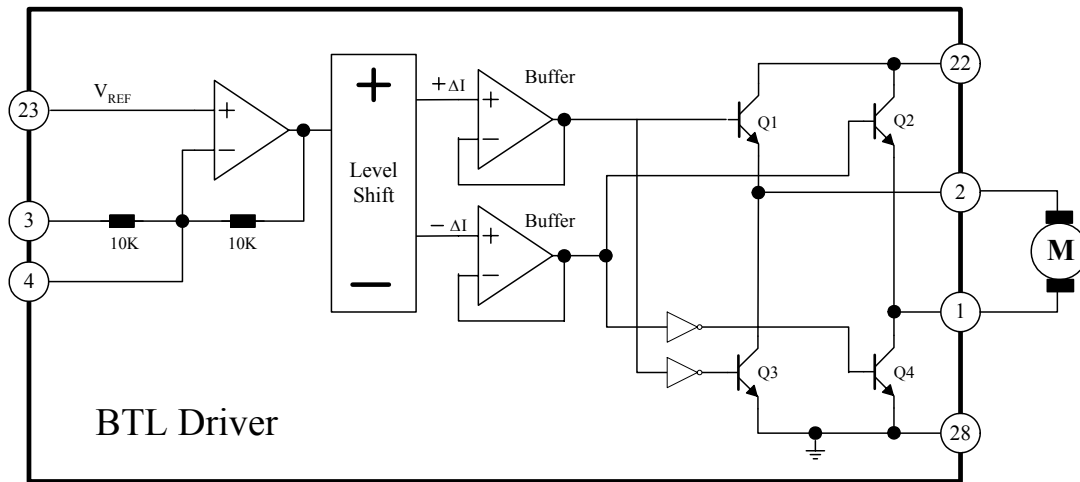

- The voltage,  $V_{REF}$ , is the reference voltage given by the bias voltage of the pin #23.
- The input signal through the pin #3 is amplified by 10K/10K times and then fed to the level shift.
- The level shift produces the current due to the difference between the input signal and the arbitrary reference signal. The current produced as  $+\Delta I$  and  $-\Delta I$  is fed into the driver buffer.
- Driver Buffer operates the power Transistor of the output stage according to the state of the input signal.
- The output stage is the BTL Driver and the motor is rotating in forward direction by operating transistor Q1 and Q4. On the other hand, if transistor Q2 and Q3 is operating, the motor is rotating in reverse direction.
- When the input voltage through the pin #3 is below the  $V_{REF}$ , then the direction of the motor in forward direction.
- When the input voltage through the pin #3 is above the  $V_{REF}$ , then the direction of the motor in reverse direction.
- If it is desired to change the gain, then the pin #4 can be used.
- When the bias voltage of the pin #23 is below 1.4V, then the output circuit is muted.  
Hence for the normal operation, the bias voltage should be used in 1.6V~6.5V.

## 7. Connect a by-pass capacitor, 0.1 $\mu$ F between the supply voltage source.

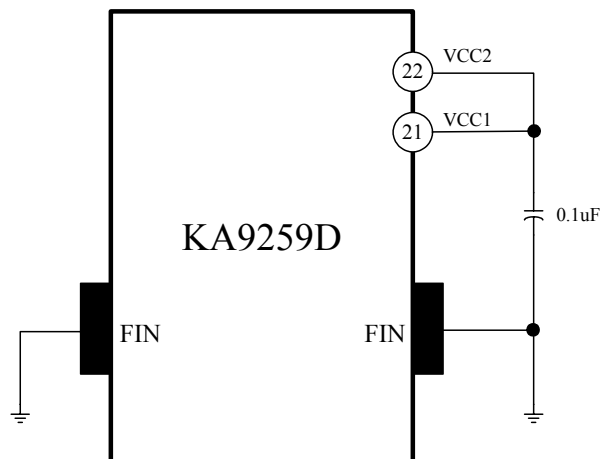

1. Radiation FIN is connecting to the internal GND of the package.
2. Connect the FIN to the external GND.

## Typical Performance Charateristics

- Test contrions: VREF=2.5[V], Mute : OFF

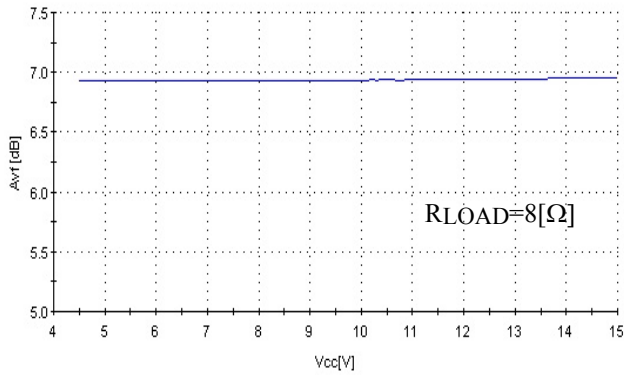

Figure 1. VCC vs. AVF

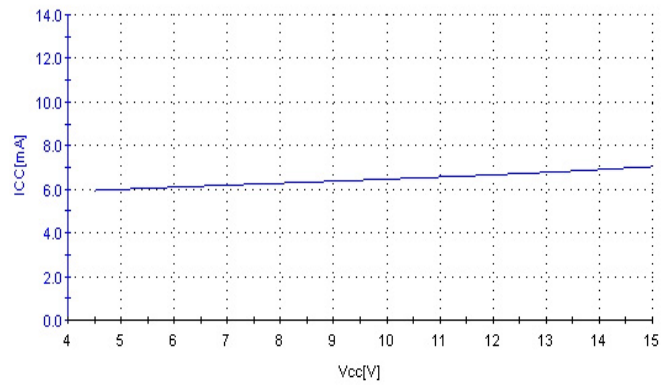

Figure 2. VCC vs. ICC

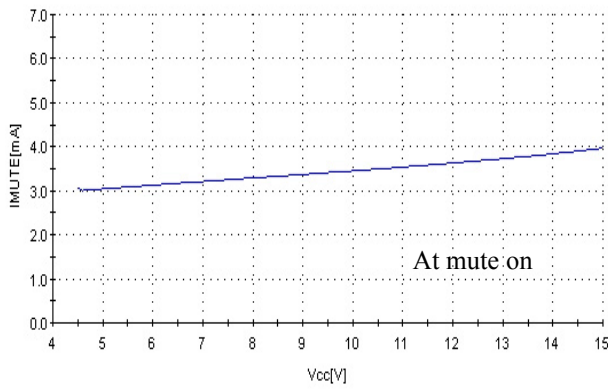

Figure 3. VCC vs. Imute

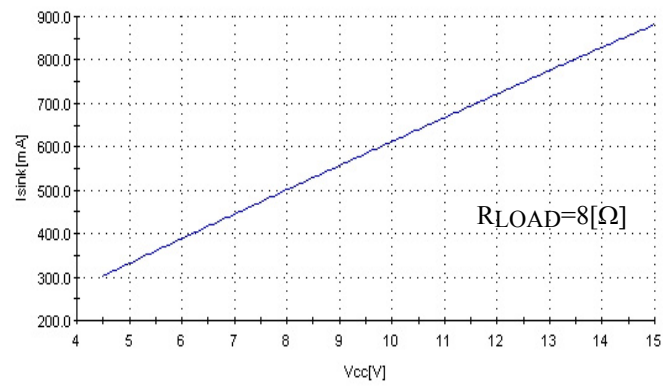

Figure 4. VCC vs. ISINK

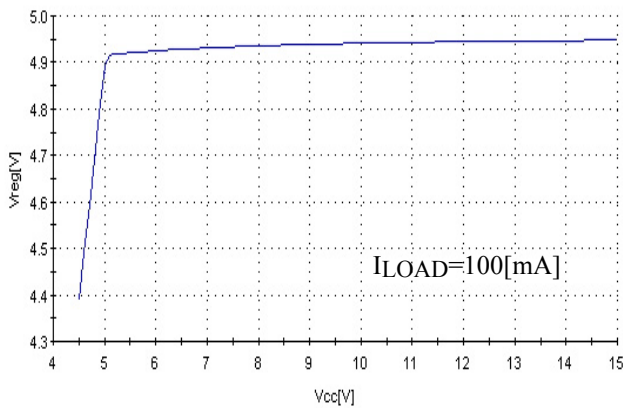

Figure 5. VCC vs. VREG

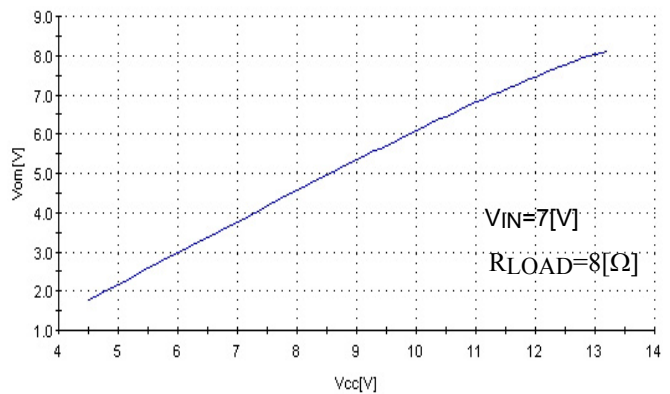
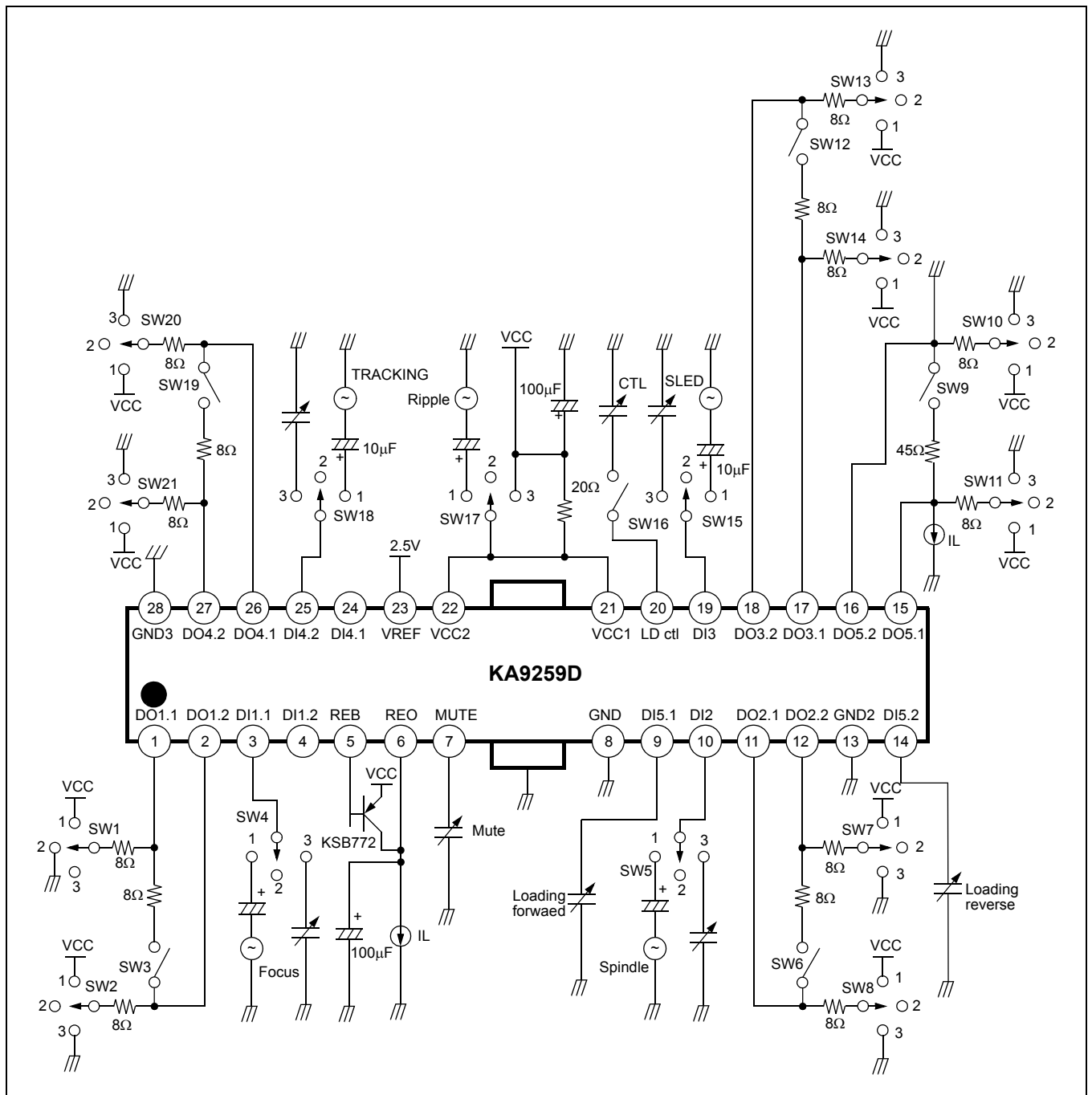
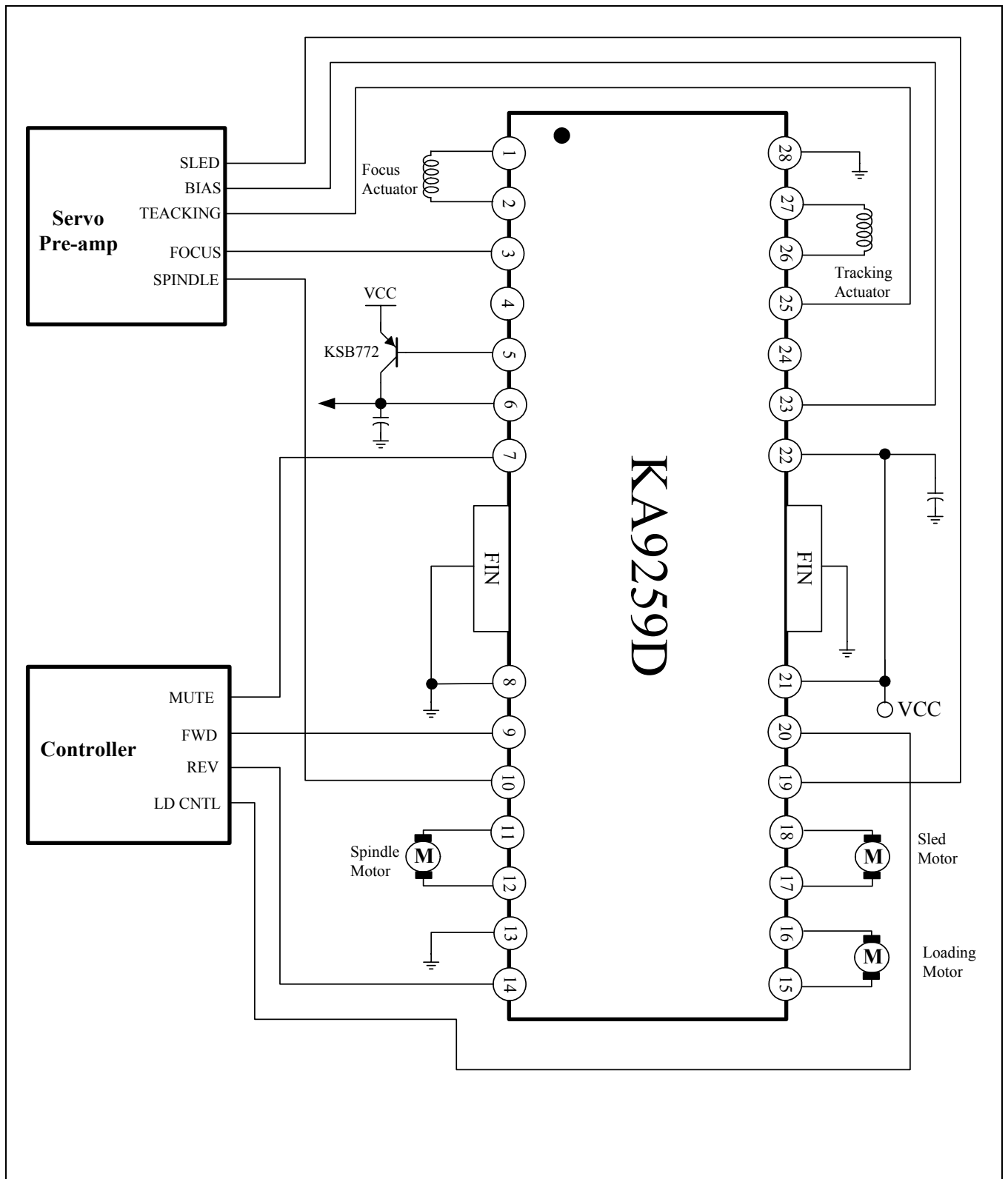

Figure 6. VCC vs. VOM

# Test Circuits



# Application Circuits



# Mechanical Dimensions

## Package

Dimensions in Millimeters

### 28-SSOPH-375

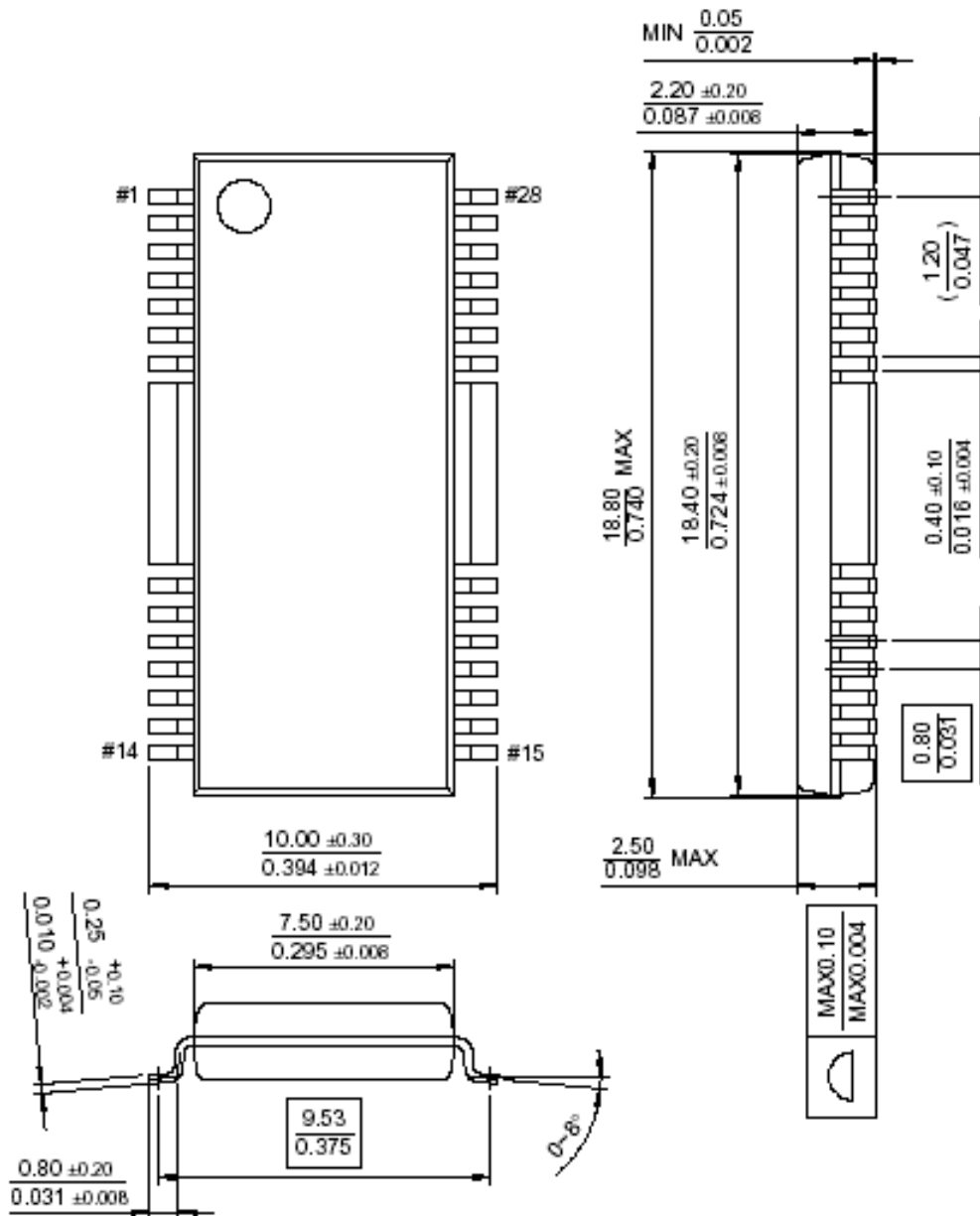



**DISCLAIMER**

FAIRCHILD SEMICONDUCTOR RESERVES THE RIGHT TO MAKE CHANGES WITHOUT FURTHER NOTICE TO ANY PRODUCTS HEREIN TO IMPROVE RELIABILITY, FUNCTION OR DESIGN. FAIRCHILD DOES NOT ASSUME ANY LIABILITY ARISING OUT OF THE APPLICATION OR USE OF ANY PRODUCT OR CIRCUIT DESCRIBED HEREIN; NEITHER DOES IT CONVEY ANY LICENSE UNDER ITS PATENT RIGHTS, NOR THE RIGHTS OF OTHERS.

**LIFE SUPPORT POLICY**

FAIRCHILD'S PRODUCTS ARE NOT AUTHORIZED FOR USE AS CRITICAL COMPONENTS IN LIFE SUPPORT DEVICES OR SYSTEMS WITHOUT THE EXPRESS WRITTEN APPROVAL OF THE PRESIDENT OF FAIRCHILD SEMICONDUCTOR CORPORATION. As used herein:

1. Life support devices or systems are devices or systems which, (a) are intended for surgical implant into the body, or (b) support or sustain life, and (c) whose failure to perform when properly used in accordance with instructions for use provided in the labeling, can be reasonably expected to result in a significant injury of the user.
2. A critical component in any component of a life support device or system whose failure to perform can be reasonably expected to cause the failure of the life support device or system, or to affect its safety or effectiveness.