

### SILICON BRIDGE RECTIFIERS

VOLTAGE RANGE: 50 --- 1000 V  
CURRENT: 2.0 A

#### FEATURES

- ◇ Rating to 1000V PRV
- ◇ Surge overload rating to 50Amperes peak
- ◇ Ideal for printed circuit board
- ◇ Reliable low cost construction utilizing molded plastic technique results in inexpensive product
- ◇ Lead solderable per MIL-STD-202 method 208

#### MECHANICAL DATA

- ◇ Polarity: Symbols molded on body
- ◇ Weight: 0.092 ounces, 2.334 grams
- ◇ Mounting position: Any

#### KBJ2

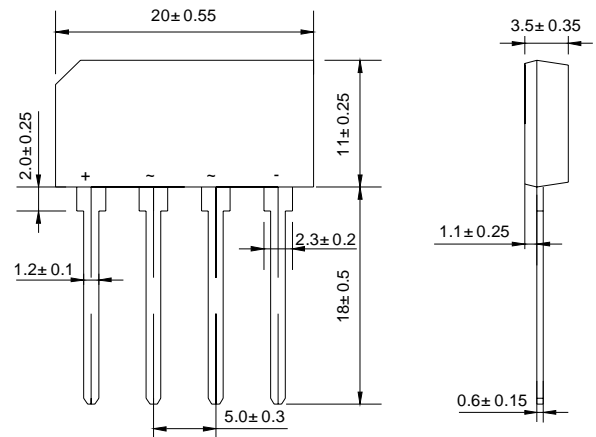

Dimensions in millimeters

#### MAXIMUM RATINGS AND ELECTRICAL CHARACTERISTICS

Ratings at 25°C ambient temperature unless otherwise specified.

Single phase, half wave, 60 Hz, resistive or inductive load. For capacitive load, derate by 20%.

		KBJ 2A	KBJ 2B	KBJ 2D	KBJ 2G	KBJ 2J	KBJ 2K	KBJ 2M	UNITS
Maximum recurrent peak reverse voltage	$V_{RRM}$	50	100	200	400	600	800	1000	V
Maximum RMS voltage	$V_{RMS}$	35	70	140	280	420	560	700	V
Maximum DC blocking voltage	$V_{DC}$	50	100	200	400	600	800	1000	V
Maximum average forward Output current @ $T_A=50^\circ\text{C}$	$I_{F(AV)}$	2.0							A
Peak forward surge current 8.3ms single half-sine-wave superimposed on rated load	$I_{FSM}$	50.0							A
Maximum instantaneous forward voltage at 1.0 A	$V_F$	1.0							V
Maximum reverse current @ $T_A=25^\circ\text{C}$ at rated DC blocking voltage @ $T_A=100^\circ\text{C}$	$I_R$	10.0 1.0							$\mu\text{A}$ mA
Typical junction capacitance per element	$C_J$	45							pF
Typical thermal resistance	$R_{\theta JC}$	2.2							$^\circ\text{C/W}$
Operating junction temperature range	$T_J$	- 55 --- + 125							$^\circ\text{C}$
Storage temperature range	$T_{STG}$	- 55 --- + 150							$^\circ\text{C}$

NOTES: 1. Measured at 1.0MHz and applied reverse voltage of 4.0V DC

2. Device mounted on 300mm X 300mm X 1.6mm cu Plate heatsink.

**FIG.1 – PEAK FORWARD SURGE CURRENT**

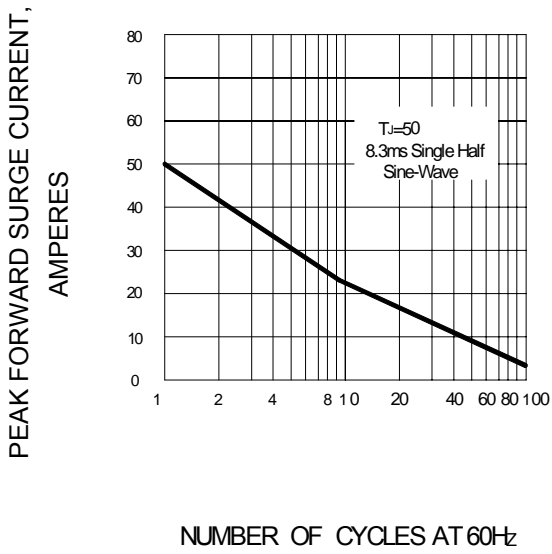

**FIG.2 – FORWARD DERATING CURVE**

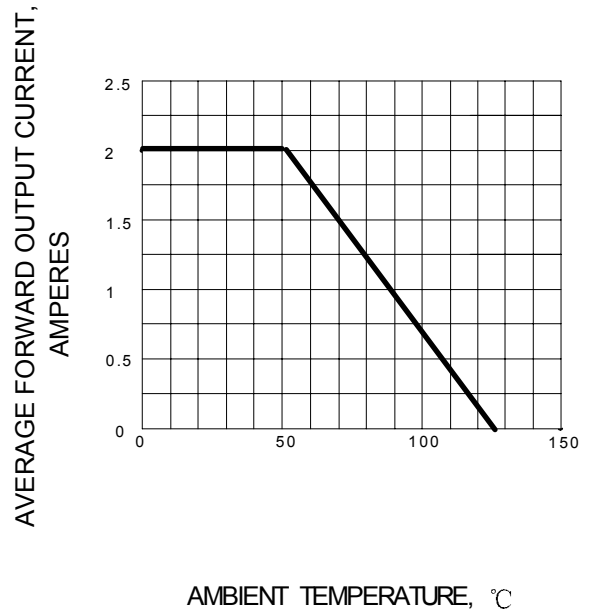

**FIG.3 – TYPICAL FORWARD CHARACTERISTIC**

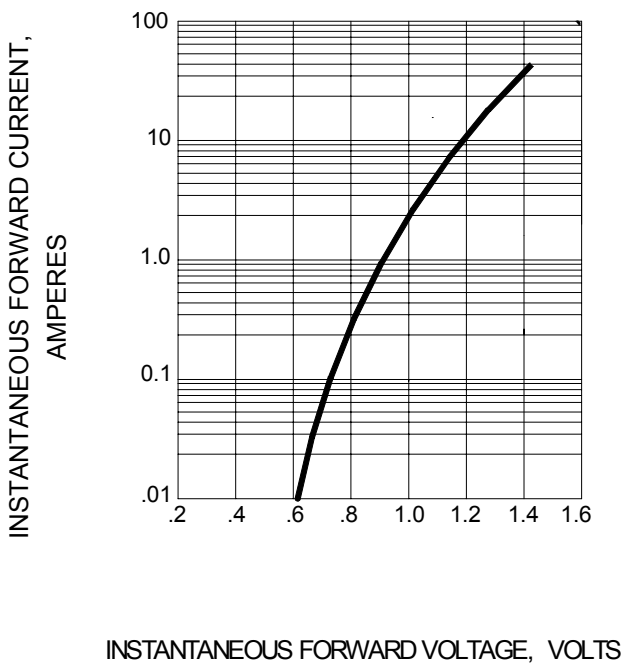

**FIG.4 – TYPICAL JUNCTION CAPACITANCE**

