

## Noise Filters KC Series

ISO 9001:2000  
CERTIFIED  
TS-16949  
CERTIFIED

### 1. Features

- Compact physical dimensions
- Excellent wave reflection control
- Exceptional EMI attenuation
- Excellent as impedance matching for signal lines
- Marking: Brown and black body color with no marking (1J & 2AF)  
White and black body color with no marking (2A)

### 2. Applications

- Clock output signal line
- In/out video signal line for super high resolution
- High speed signal line
- Noise reduction for various signal circuits

### 3. Ordering & Specifying Information

Type designation shall be as the following form.

KC	2AF	T	TE	120	N	6N5	L
Type	Size	Termination Material	Packaging	Capacitance Value (pF)	Capacitance Tolerance	Inductance Value (nH)	Inductance Tolerance
	1J 2AF 2A	T: Sn L: SnPb	TD: 7" paper tape (1J & 2AF only - 4,000 pieces/reel) TE: 7" embossed plastic (2A only - 2,000 pcs/reel)	2 significant digits + num. of zeros	N: ±30% P: ±25%	6.5nH	L: ±15%

### 4. Circuit Schematic

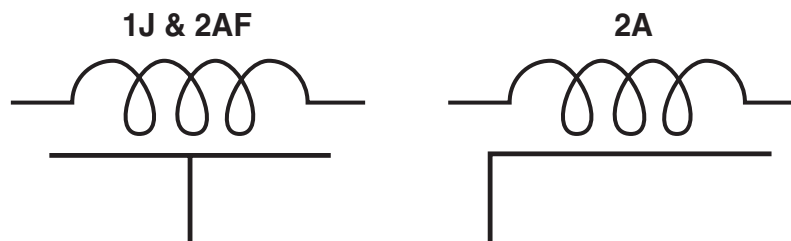

**5. Rating**

Item	Specification
Operating temperature range	-25°C ~ +85°C (1J & 2AF) -40°C ~ +85°C (2A)
Storage temperature range	-40°C ~ +85°C (After soldering)
Measuring condition (Standard)	
Temperature	15 ~ 35°C
Relative humidity	20 ~ 90%
Measuring condition (Precision)	
Temperature	20°C ±1°C
Relative humidity	60 ~ 67%

**6. Dimension**

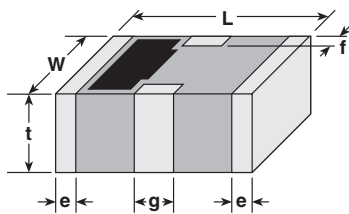

**1J & 2AF**

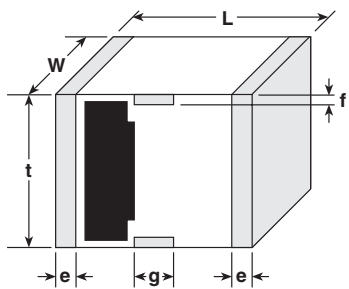

**2A**

Size	Dimensions inches (mm)					
	L	W	t	g	e	f
<b>1J</b>	.062±.008 (1.6±0.2)	.031±.008 (0.8±0.2)	.024±.008 (0.6±0.2)	.016±.012 (0.4±0.3)	.008±.006 (0.2±0.15)	N/A
<b>2AF</b>	.079±.008 (2.0±0.2)	.049±.008 (1.25±0.2)	.031±.008 (0.8±0.2)	.016±.012 (0.4±0.3)	.012±.008 (0.3±0.2)	N/A
<b>2A</b>	.079±.008 (2.0±0.2)	.049±.008 (1.25±0.2)	.063±.008 (1.6±0.2)	.016±.008 (0.4±0.2)	.004 Min. (0.1 Min.)	.02±.006 (0.25±0.15)

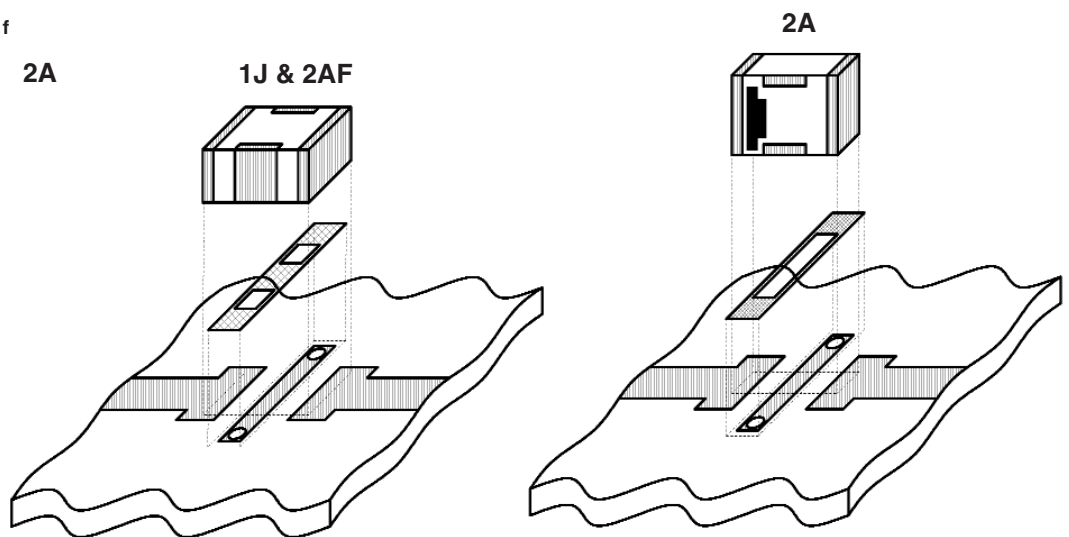

## 7. Applications and Ratings

Item	Specification
Operating Temperature Range	-25°C to +85°C (1J & 2AF) -40°C to +85°C (2A)
Storage Temperature Range	-40°C to +85°C (after soldering)
Measuring Condition (Standard) Temperature Relative Humidity	15°C to 35°C 20 - 90%
Measuring Condition (Precision) Temperature Relative Humidity	20°C ± 1°C 60 - 67%

Part Designation	Capacitance (pF) %	Inductance (nH) %	Rated Voltage DC (V)	Rated Current DC (A)	Insulation Resistance Minimum (MΩ)	Operating Temperature Range	Typical Cut-off Frequency (Att = 3dB)
KC1JTTD220P8N0L	22 ± 25%	8.0 ± 15%	16	200	1000	-25°C to +85°C	200 MHz
KC1JTTD350P8N0L	35 ± 25%	8.0 ± 15%					100 MHz
KC1JTTD550P8N0L	55 ± 25%	8.0 ± 15%					50 MHz
KC2AFLTD151N16N5L	150 ± 30%	16.5 ± 15%	25	200	1000	-25°C to +85°C	50 MHz
KC2AFLTD700N8N50L	70 ± 30%	8.5 ± 15%					100 MHz
KC2ALTE120N6N5L	12 ± 30%	6.5 ± 15%					530 MHz
KC2ALTE180N13NL	18 ± 30%	13 ± 15%	25	200	1000	-40°C to +85°C	360 MHz
KC2ALTE350N15NL	35 ± 30%	15 ± 15%					180 MHz

## 8. Pattern design

The land pattern is recommended as follows.

### Chip Mounting Side

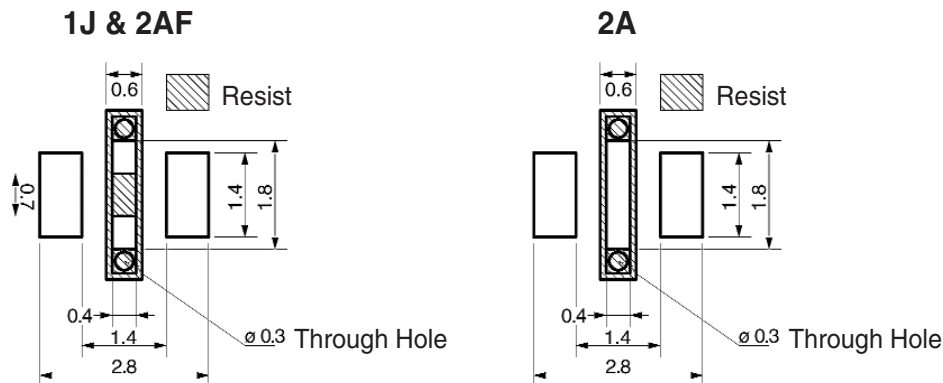

### Back Side

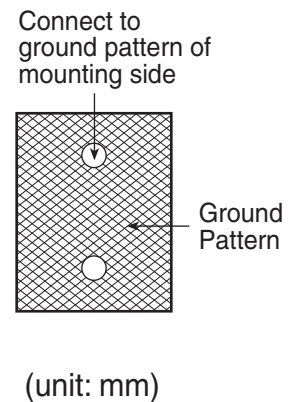

## 9. Characteristics

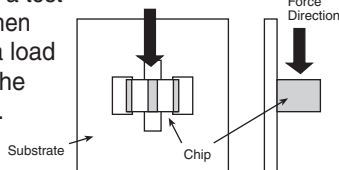
Item	Requirement	Conditions
Insulation Resistance	Within the tolerance	<b>Voltage:</b> DC25V <b>Test Time:</b> 60 sec
Capacitance	Within the tolerance	<b>Frequency:</b> 1MHz <b>Voltage:</b> 1V <b>Equipment:</b> HP4192A <b>Fixture:</b> HP16034E
Inductance	Within the tolerance	<b>Frequency:</b> 1MHz <b>Current:</b> 10mA <b>Equipment:</b> HP4192A <b>Fixture:</b> HP16034E
Resistance (2A only)	Within the tolerance	<b>Frequency:</b> 1MHz <b>Current:</b> 10mA <b>Equipment:</b> HP4192A <b>Fixture:</b> HP16034E
Capacitance vs. Temperature Characteristics	Variation rate of capacitance in operate temperature are shown in below. <b>Part</b> KC2AL120N6NSL KC2AL180N13NL KC2AL350N15NL <b>Rate</b> ± 10% ± 10% ± 10%	The capacitance shall be measured at each stage below. The rate shall be calculated against the capacitance measured at 20°C <b>Step</b> <b>Temperature</b> 1            20°C 2            -40°C ± 3°C 3            20°C 4            85°C ± 3°C
Terminal Adhesion Strength	No physical damage	Solder a chip to a test substrate and then laterally apply a load (5N, 500gf) in the arrow direction. 
Resistance to Soldering Heat	<b>Appearance:</b> No physical damage <b>Capacitance:</b> Within tolerance <b>Dielectric Loss:</b> Within tolerance <b>Insulation Resistance:</b> Within tolerance <b>Withstand Voltage:</b> No abnormality	<b>Flux:</b> 25% rosin <b>Pre-heating:</b> 120 to 180 sec <b>Pre-heating Temp:</b> 150°C to 200°C (1J & 2AF) <b>Solder:</b> H60A <b>Solder Temp:</b> 260°C ±5°C <b>Dip Time:</b> 5 ±0.5 sec

## 9. Characteristics Cont.

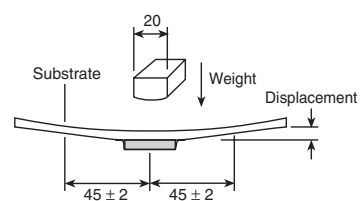
Item	Requirement	Conditions															
Solderability	More than 95% of the terminal electrode shall be covered with new solder.	<b>Flux:</b> 25% rosin <b>Solder:</b> H60A <b>Solder Temp:</b> 235°C ±5°C <b>Dip Time:</b> 2 ±0.5 sec															
Temperature Cycle*	<b>Appearance:</b> No physical damage <b>Capacitance:</b> Within tolerance <b>Dielectric Loss:</b> Within tolerance <b>Insulation Resistance:</b> Within tolerance <b>Withstand Voltage:</b> No abnormality	Repeat the following heat cycle 10 times: <table border="1"> <thead> <tr> <th>Step</th> <th>Temperature</th> <th>Time</th> </tr> </thead> <tbody> <tr> <td>1</td> <td>-40°C ±3°C</td> <td>30 min ±3 min</td> </tr> <tr> <td>2</td> <td>Room Temp.</td> <td>15 min max.</td> </tr> <tr> <td>3</td> <td>85°C ±2°C</td> <td>30 min ±3 min</td> </tr> <tr> <td>4</td> <td>Room Temp.</td> <td>15 min max.</td> </tr> </tbody> </table>	Step	Temperature	Time	1	-40°C ±3°C	30 min ±3 min	2	Room Temp.	15 min max.	3	85°C ±2°C	30 min ±3 min	4	Room Temp.	15 min max.
Step	Temperature	Time															
1	-40°C ±3°C	30 min ±3 min															
2	Room Temp.	15 min max.															
3	85°C ±2°C	30 min ±3 min															
4	Room Temp.	15 min max.															
High Temperature Resistance*	<b>Appearance:</b> No physical damage <b>Capacitance:</b> Within tolerance <b>Dielectric Loss:</b> Within tolerance <b>Insulation Resistance:</b> Within tolerance <b>Withstand Voltage:</b> No abnormality	<b>Temp:</b> 70°C ±2°C <b>Bias:</b> DC25V <b>Bias:</b> DC200mA <b>Test Time:</b> 500 hours															
Humidity Resistance (unload)*	<b>Appearance:</b> No physical damage <b>Capacitance:</b> Within tolerance <b>Dielectric Loss:</b> Within tolerance <b>Insulation Resistance:</b> Within tolerance	<b>Temp:</b> 85°C ±2°C <b>Humidity:</b> 85% ±5% <b>Test Time:</b> 500 hours															
Substrate Bending Test	<b>Appearance:</b> No physical damage <b>Capacitance:</b> Within tolerance	After soldering a chip to a test substrate, bend the substrate by 1 mm and then measure. The substrate is GE4 or based on GE4. 															
Humidity Resistance (load)*	<b>Appearance:</b> No physical damage <b>Capacitance:</b> Within tolerance <b>Dielectric Loss:</b> Within tolerance <b>Insulation Resistance:</b> Within tolerance	<b>Temp:</b> 40°C ±2°C <b>Humidity:</b> 90% ~ 95% <b>Bias:</b> DC25V <b>Bias:</b> DC200mA <b>Test Time:</b> 500 hours															

\* After Temperature cycle test, High temperature resistance test, Humidity resistance test or Low temperature resistance test, the tested sample should be measured after having left in temperature from 15° to 35°C and relative humidity from 20% to 90% for 24 hours.

## 10. Packaging Specifications

### 10.1 Taping

Packaging of components on continuous tape is complete with carrier tape for putting components and cover tape for sealing.

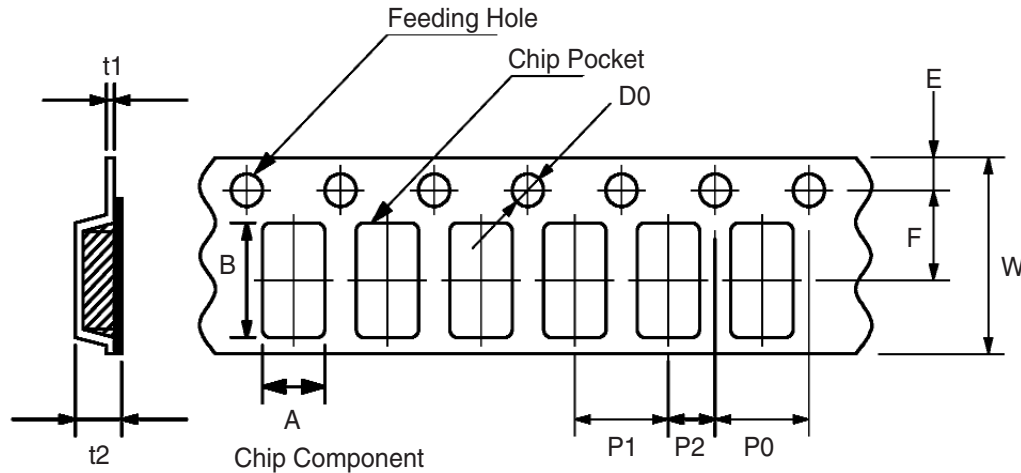

(1) Dimensions of Carrier Tape

Dimensions in inches (mm)

Series	A	B	W	F	E	P1
KC1J Series	0.043 ± 0.002 (1.1 ± 0.05)	0.075 ± 0.002 (1.9 ± 0.05)	0.314 ± 0.003 (8.0 ± 0.1)	N/A	0.068 ± 0.003 (1.75 ± 0.1)	0.157 ± 0.003 (4.0 ± 0.1)
KC2AF Series	0.061 ± 0.003 (1.55 ± 0.1)	0.090 ± 0.003 (2.3 ± 0.1)	0.314 ± 0.0078 (8.0 ± 0.2)	0.137 ± 0.001 (3.5 ± 0.05)	0.068 ± 0.003 (1.75 ± 0.1)	0.157 ± 0.003 (4.0 ± 0.1)
KC2A Series	0.061 ± 0.003 (1.55 ± 0.1)	0.090 ± 0.003 (2.3 ± 0.1)	0.314 ± 0.0078 (8.0 ± 0.2)	0.137 ± 0.001 (3.5 ± 0.05)	0.068 ± 0.003 (1.75 ± 0.1)	0.157 ± 0.003 (4.0 ± 0.1)

Dimensions in inches (mm)

Series	P2	P0	D0	t1	t2
KC1J Series	0.078 ± 0.001 (2.0 ± 0.05)	0.157 ± 0.003 (4.0 ± 0.1)	0.059 <sup>+0.003</sup> <sub>-0</sub> (1.5 <sup>+0.1</sup> <sub>-0</sub> )	0.037 ± 0.001 (0.95 ± 0.05)	0.030 ± 0.002 (0.75 ± 0.04)
KC2AF Series	0.078 ± 0.001 (2.0 ± 0.05)	0.157 ± 0.003 (4.0 ± 0.1)	0.059 <sup>+0.003</sup> <sub>-0</sub> (1.5 <sup>+0.1</sup> <sub>-0</sub> )	0.037 ± 0.001 (0.95 ± 0.05)	N/A
KC2A Series	0.078 ± 0.001 (2.0 ± 0.05)	0.157 ± 0.003 (4.0 ± 0.1)	0.059 <sup>+0.003</sup> <sub>-0</sub> (1.5 <sup>+0.1</sup> <sub>-0</sub> )	0.009 ± 0.001 (0.25 ± 0.05)	0.074 ± 0.003 (1.9 ± 0.1)

(1) Dimensions of Carrier Tape Cont.

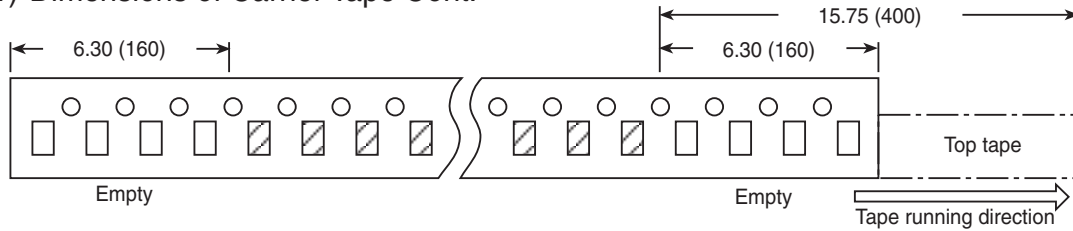

(2) Reel dimensions

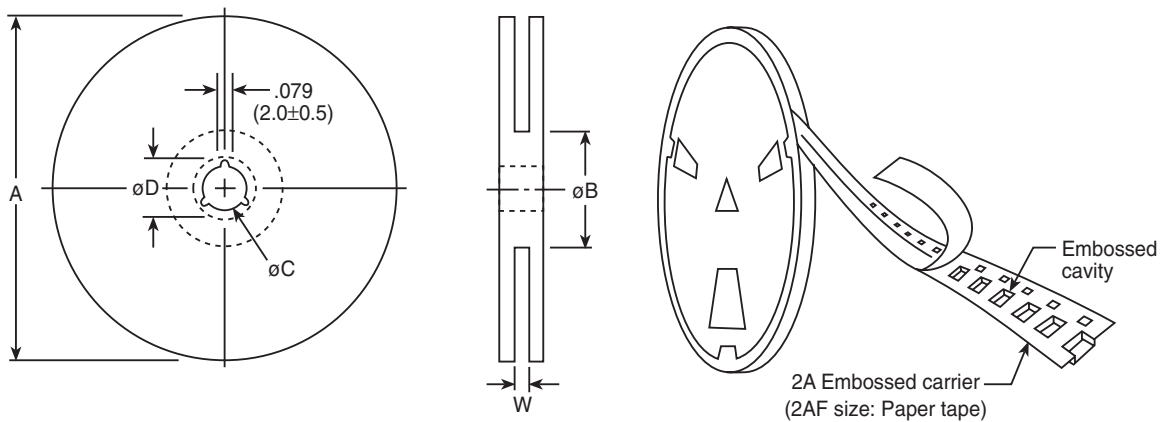

Dimensions in inches (mm)

	A	B	C	D	E	W (min)	W (max)
<b>KC Series</b>	7.00 ± 0.78 (178 ± 2)	2.36 (60 min)	0.511 ± 0.02 (13 ± 0.5)	0.83 ± 0.03 (21 ± 0.8)	0.079 ± 0.02 (2 ± 0.5)	0.311 ± 0.059 (7.9 ± 1.5)	0.429 ± 0.059 (10.9 ± 1.5)

**10.2 Construction of Packaging on Continuous Tapes (2AF only)**

Packaging of components on continuous tape is complete with carrier tape for putting components and cover tape for sealing.

Materials

- Reel: Polystyrene
- Carrier Tape: Paper
- Top Cover Tape: Polyester base
- Bottom Cover Tape: Paper

**11. General Information**

**(1) Storage**

The products must be stored from 10° to 35°C and from 30% to 70% RH before soldering.

**(2) Soldering**

In general, ceramics are very sensitive to thermal shocks. Therefore the parts shall not be exposed to a sudden temperature increase, decrease or partial heating.

Products shall be pre-heated prior to soldering. The temperature difference between the solder temperature and product temperature does not exceed 130°C.

It is desirable that the soldering temperature be kept 240° - 250°C and that soldering time be less than 4 seconds.

Flux shall be rosin type. Do not use strong acid type flux.

The tip of the soldering iron shall be 20 W or less, 3f or less, and 220° - 250° C.

Recommended soldering thermal and time conditions are shown Appendix 2.

**(3) Mounting**

After mounting components on the printed circuit board, do not apply stress through board bending or mishandling.

**12. Recommended Soldering Conditions**

**Recommended Condition for Reflow Soldering**

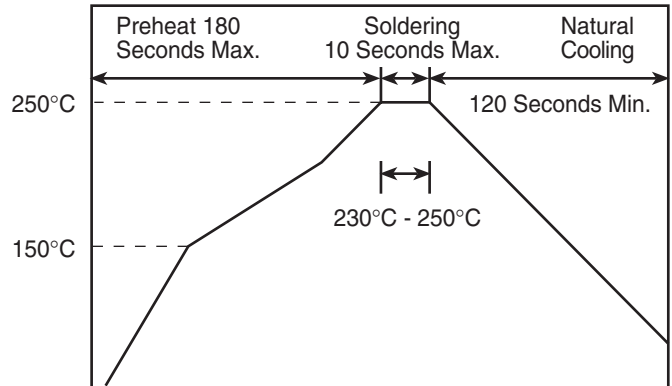

**Recommended Condition for Flow Soldering**

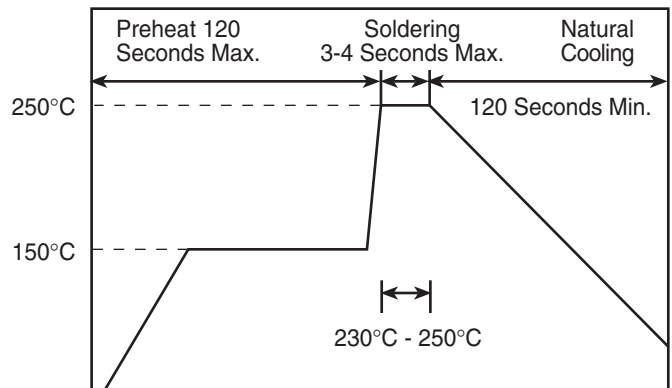

**Recommended Condition for Iron Soldering**

