

# SBD Type : KCH30A09

OUTLINE DRAWING

### FEATURES

- \* Similar to TO-247AC(TO-3P)Case
- \* Dual Diodes – Cathode Common
- \* Low Forward Voltage Drop
- \* Low Power Loss,High Efficiency
- \* High Surge Current Capability
- \* Tj=150°C operation

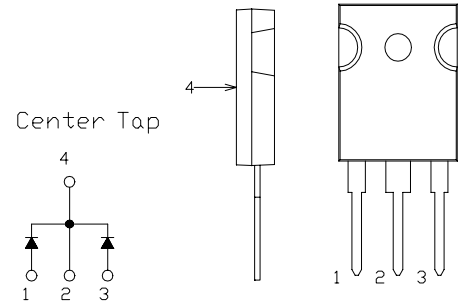

### Maximum Ratings

Approx Net Weight: 5.55g

Rating	Symbol	KCH30A09		Unit
Repetitive Peak Reverse Voltage	$V_{RRM}$	90		V
Average Rectified Output Current	$I_O$	30	$T_c=112^\circ\text{C}$ 50 Hz Full Sine Wave Resistive Load	A
RMS Forward Current	$I_{F(RMS)}$	33.3		A
Surge Forward Current	$I_{FSM}$	250	50Hz Full Sine Wave ,1cycle Non-repetitive	A
Operating JunctionTemperature Range	$T_{jw}$	-40 to +150		°C
Storage Temperature Range	$T_{stg}$	-40 to +150		°C
Mounting torque	$F_{tor}$	recommended torque = 0.5		N•m

### Electrical • Thermal Characteristics

Characteristics	Symbol	Conditions	Min.	Typ.	Max.	Unit
Peak Reverse Current	$I_{RM}$	$T_j= 25^\circ\text{C}$ , $V_{RM}= V_{RRM}$ per Arm	-	-	2	mA
Peak Forward Voltage	$V_{FM}$	$T_j=25^\circ\text{C}$ , $I_{FM}= 15\text{A}$ per Arm	-	-	0.88	V
Thermal Resistance	$R_{th(j-c)}$	Junction to Case	-	-	1.3	°C/W

KCH30A09 OUTLINE DRAWING (Dimensions in mm)

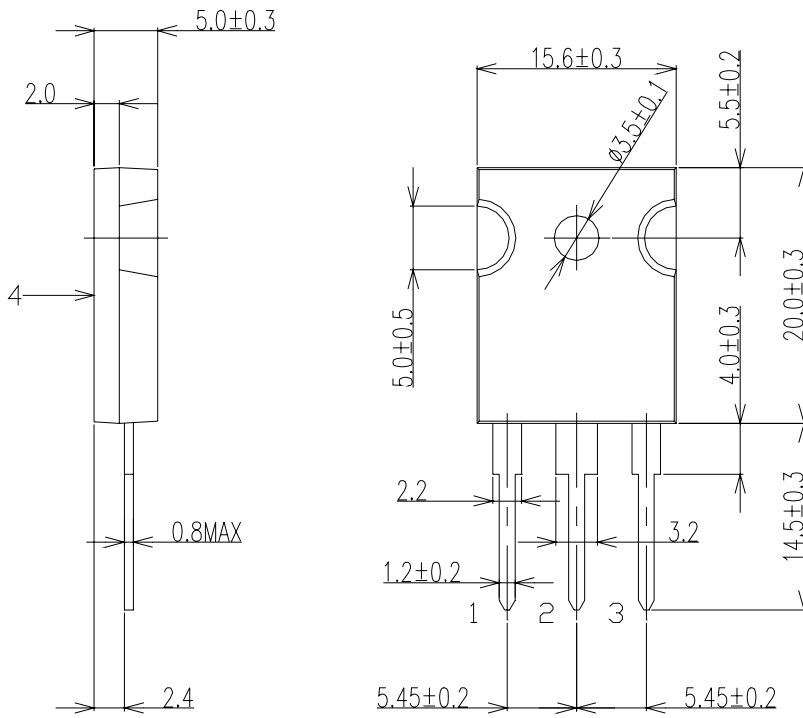

Center Tap

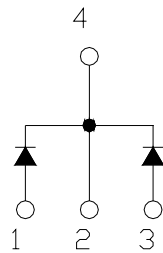

### FORWARD CURRENT VS. VOLTAGE

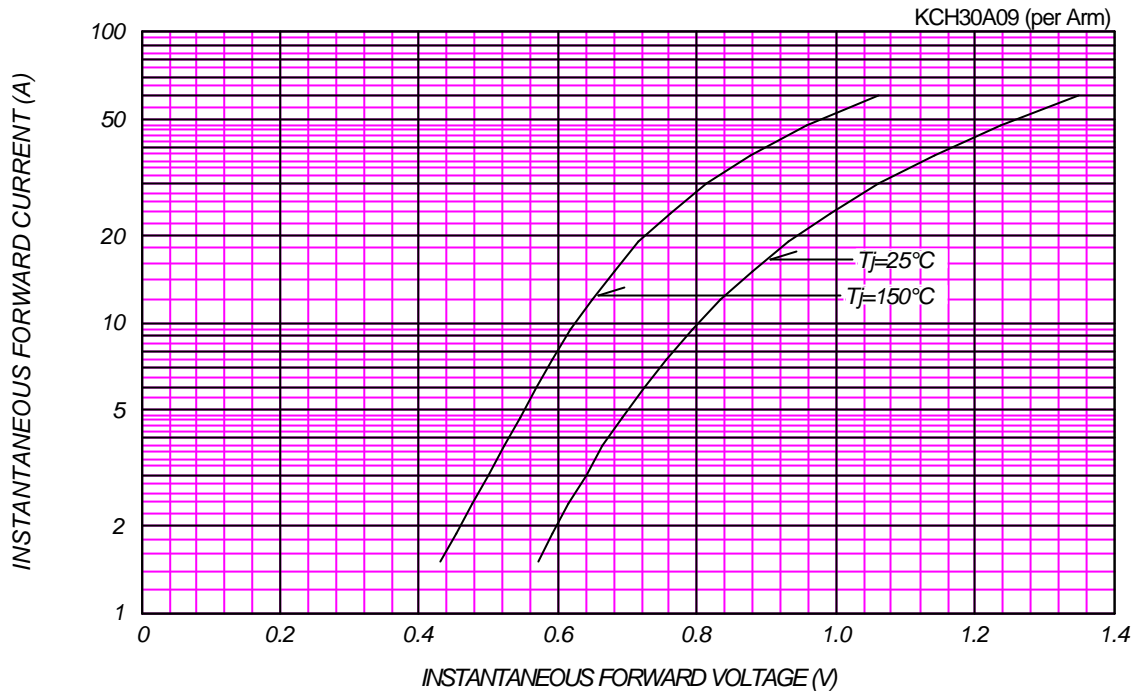

### AVERAGE FORWARD POWER DISSIPATION

