

### SINGLE OPERATIONAL AMPLIFIER

- In the Linear Mode the Input Common Mode Voltage Range Includes Ground.
- Low Power Dissipation and Power Drain Suitable for Battery Operation.
- Differential Input Voltage Range Equal to the Power Supply Voltage.
- Wide Power Supply Voltage Range and Signal Power Supply : Single Supply  $3V_{DC}$  to  $36V_{DC}$   
Dual Supplies  $\pm 1.5V_{DC}$  to  $\pm 18V_{DC}$
- Large Output Voltage Swing :  $0V_{DC}$  to  $V_{CC}-1.5V_{DC}$
- Low Input Biasing Current :  $I_I=45nA_{DC}$  (Typ.)

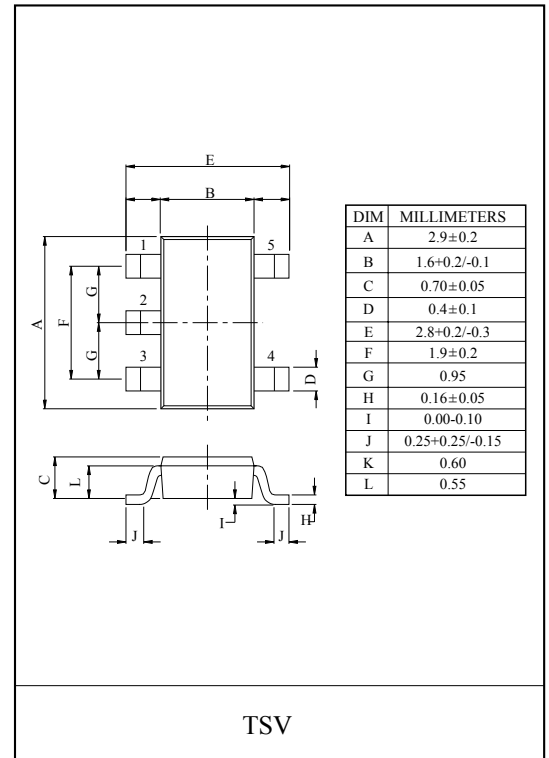

### PIN CONNECTION (TOP VIEW)

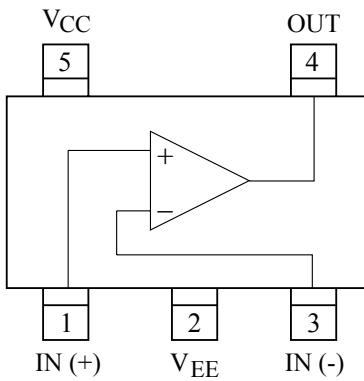

### Marking (TOP VIEW)

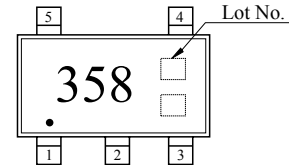

### MAXIMUM RATING (Ta=25°C)

CHARACTERISTIC	SYMBOL	RATING	UNIT
Supply Voltage	$V_{CC}$	36, +18	V
	$V_{EE}$	0, -18	
Differential Input Voltage	$DV_{IN}$	$\pm 36$	V
Input Voltage	$V_{IN}$	-0.3 ~ 36	V
Power Dissipation	$P_D$	200	mW
Operating Temperature	$T_{opr}$	-40 ~ 85	°C
Storage Temperature	$T_{stg}$	-55 ~ 125	°C

# KIA75S358F

## EQUIVALENT CIRCUIT

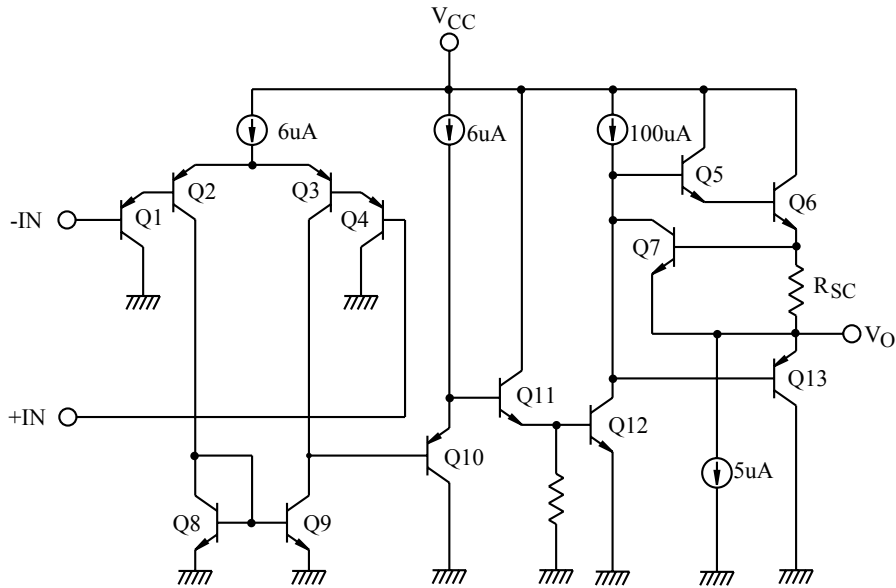

## ELECTRICAL CHARACTERISTICS ( $V_{CC}=5V$ , $V_{EE}=GND$ , $T_a=25^\circ C$ )

CHARACTERISTIC	SYMBOL	TEST CONDITION	MIN.	TYP.	MAX.	UNIT
Input Offset Voltage	$V_{IO}$	$R_g \leq 10k\Omega$	-	2	7	mV
Input Offset Current	$I_{IO}$	-	-	5	30	nA
Input Bias Current	$I_I$	-	-	45	150	nA
Common Mode Input Voltage	$CMV_{IN}$	$V_{CC}=30V$ , $V_{EE}=GND$	0	-	$V_{CC}-1.5$	V
Supply Current	$I_{CC}$ , $I_{EE}$	$R_L=\infty$ , All OP Amps	-	0.4	0.8	mA
Voltage Gain	$G_V$	$R_L \geq 2k\Omega$	86	100	-	dB
Maximum Output Voltage Swing	$V_{OP-P}$	$R_L=2k\Omega$	0	$V_{CC}-1.5$	-	V
Common Mode Input Signal Rejection Ratio	CMRR	-	60	85	-	dB
Supply Voltage Rejection Ratio	SVRR	$R_g=10k\Omega$	60	100	-	dB
Source Current	$I_{source}$	$-IN=0V_{DC}$ , $+IN=1V_{DC}$	20	40	-	mA
Sink Current	$I_{sink}$	$-IN=1V_{DC}$ , $+IN=0V_{DC}$	10	20	-	mA

# KIA75S358F

$V_{CC} - I_{CC}$

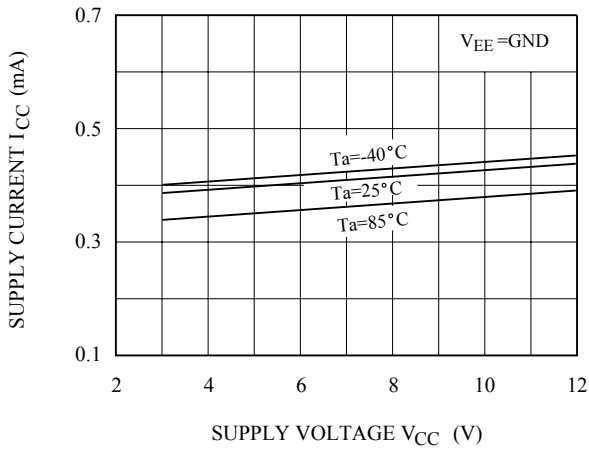

$V_{CC} - I_I$

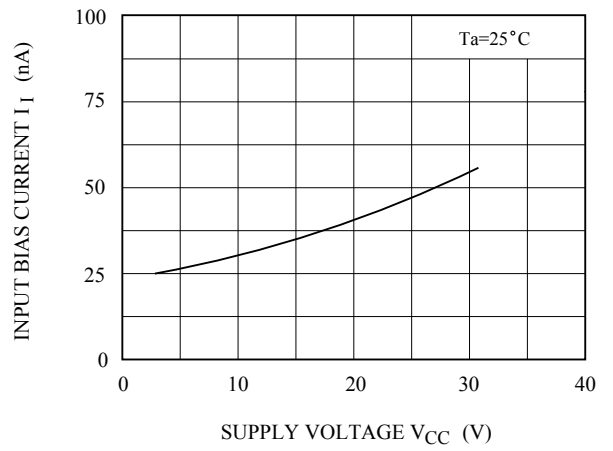

$V_{CC} - G_V$

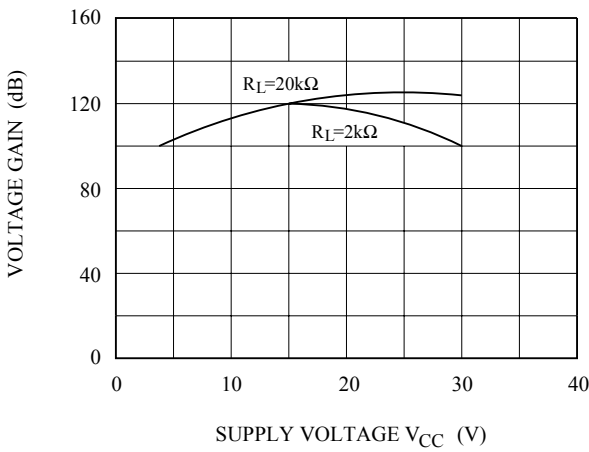

$I_{SOURCE} - T_a$

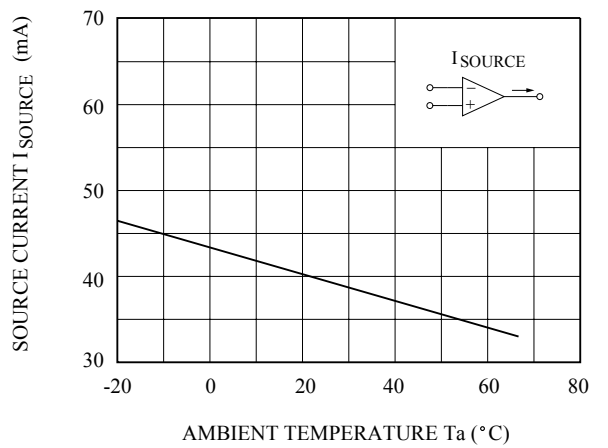

CMRR - f

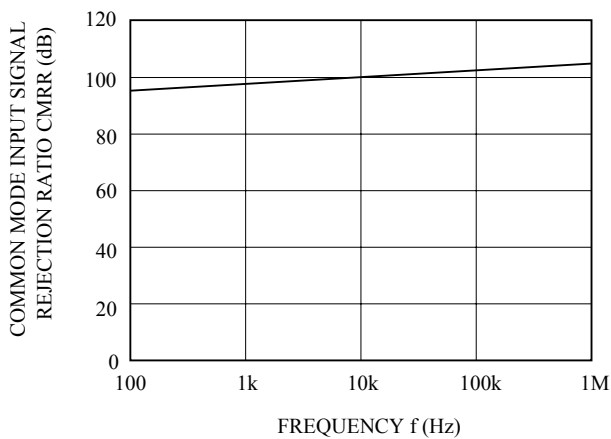

$G_V - f$

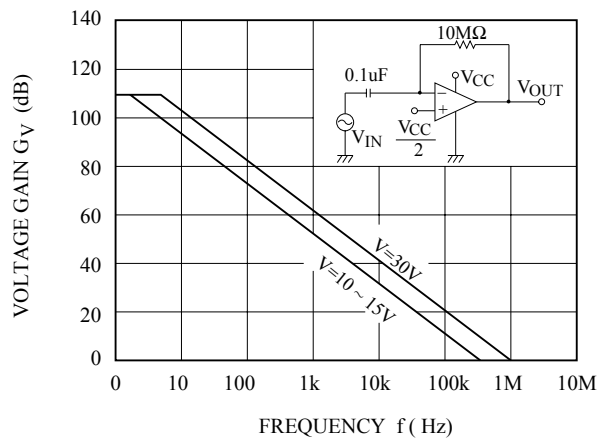

# KIA75S358F

