

DATA SHEET

KM110B/2 Magnetic field sensor

Preliminary specification
File under Discrete Semiconductors, SC17

November 1994

Philips Semiconductors



PHILIPS

Magnetic field sensor

KM110B/2

DESCRIPTION

The KM110B/2 is a sensitive magnetic field sensor, employing the magnetoresistive effect in thin-film permalloy. A Ferroxdure FXD100 magnet mounted on the back of the sensor package provides an auxiliary field of 3.6 kA/m in the x-direction of the sensor.

Typical applications for the KM110B/2 are current measurement, linear position measurement, rotational speed detection of magnetic pole wheels as well as magnetic field measurement. The sensor can be operated at any frequency between DC and 1 MHz.

PINNING

PIN	SYMBOL	DESCRIPTION
1	+V _O	output voltage
2	GND	ground
3	-V _O	output voltage
4	+V _{CC}	supply voltage

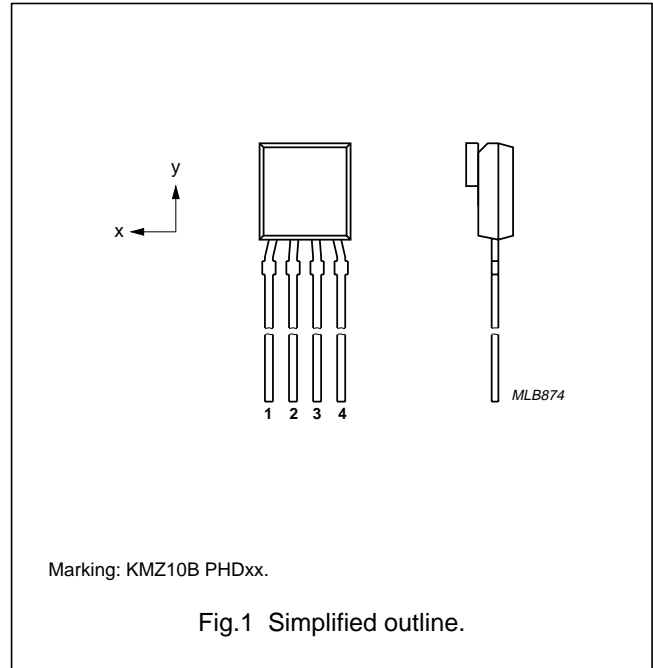

QUICK REFERENCE DATA

SYMBOL	PARAMETER	MIN.	TYP.	MAX.	UNIT
V _{CC}	DC supply voltage	-	5	-	V
T _{bridge}	bridge operating temperature	-40	-	150	°C
H _y	magnetic field strength	-2.2	-	+2.2	kA/m
S	sensitivity	-	3.6	-	$\frac{mV/V}{kA/m}$
R _{bridge}	bridge resistance	1.6	2.1	2.6	kΩ
V _{offset}	offset voltage	-0.5	-	+0.5	mV/V

CIRCUIT DIAGRAM

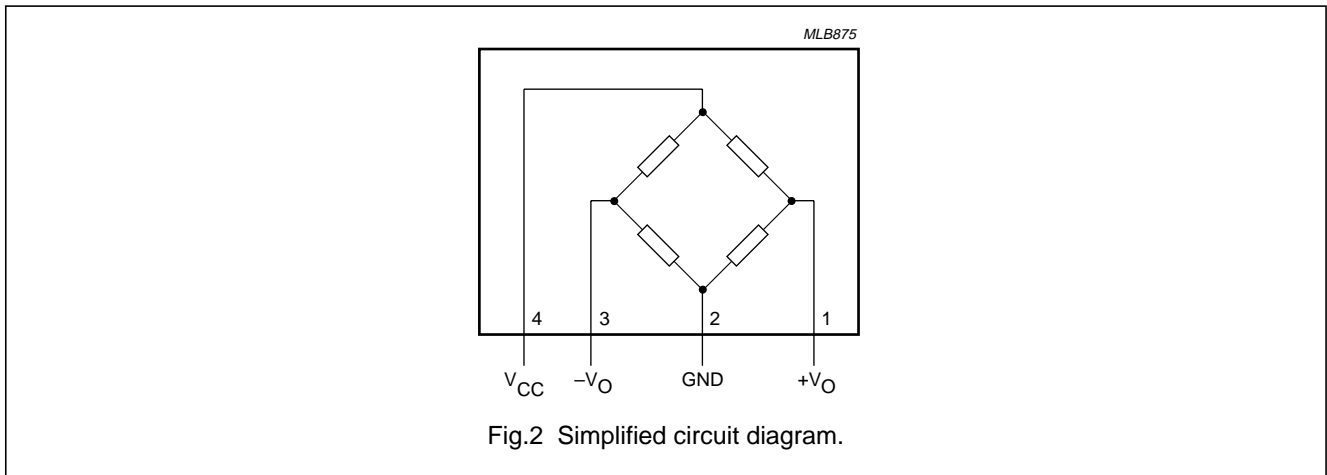

Magnetic field sensor

KM110B/2

LIMITING VALUES

In accordance with the Absolute Maximum Rating System (IEC 134).

SYMBOL	PARAMETER	CONDITIONS	MIN.	MAX.	UNIT
V_{CC}	DC supply voltage		–	12	V
P_{tot}	total power dissipation	up to $T_{amb} = 130\text{ °C}$; see Fig.5	–	120	mW
T_{stg}	storage temperature	note 1	–40	+150	°C
T_{bridge}	bridge operating temperature		–40	+150	°C

Note

1. Maximum operating temperature of the thin-film permalloy.

THERMAL CHARACTERISTICS

SYMBOL	PARAMETER	VALUE	UNIT
$R_{th\ j-a}$	thermal resistance from junction to ambient	180	K/W

CHARACTERISTICS $T_{amb} = 25\text{ °C}$; $V_{CC} = 5\text{ V}$ unless otherwise specified.

SYMBOL	PARAMETER	CONDITIONS	MIN.	TYP.	MAX.	UNIT
H_y	magnetic field strength	note 1	–2.2	–	+2.2	kA/m
S	sensitivity	open circuit; notes 2 and 3	2.9	3.6	4.4	$\frac{mV/V}{kA/m}$
TCV_O	temperature coefficient of output voltage	$V_{CC} = -5\text{ V}$; $T_{amb} = -25\text{ to }+125\text{ °C}$	–	–0.4	–	%/K
		$I_{CC} = 3\text{ mA}$; $T_{amb} = -25\text{ to }+125\text{ °C}$	–	–0.1	–	%/K
R_{bridge}	bridge resistance		1.6	–	2.6	k Ω
TCR_{bridge}	temperature coefficient of bridge resistance	$T_{bridge} = -25\text{ to }+125\text{ °C}$	–	0.3	–	%/K
V_{offset}	offset voltage		–0.5	–	+0.5	mV/V
TCV_{offset}	temperature coefficient of offset voltage	$T_{bridge} = -25\text{ to }+125\text{ °C}$	–5	± 1.5	5	($\mu V/V$)/K
FL	linearity deviation of output voltage	$H_y = 0\text{ to } \pm 1\text{ kA/m}$	–	–	0.5	%-FS
		$H_y = 0\text{ to } \pm 1.6\text{ kA/m}$	–	–	1.7	%-FS
		$H_y = 0\text{ to } \pm 2\text{ kA/m}$	–	–	2.0	%-FS
FH	hysteresis of output voltage		–	–	0.5	%-FS
f	operating frequency	note 4	0	–	1	MHz

Magnetic field sensor

KM110B/2

Notes to the characteristics

1. Magnet (Ferroxdure 100) delivers an auxiliary field of $H_x = 3.6 \text{ kA/m}$ (temperature coefficient: -0.2 %/K). Above $110 \text{ }^\circ\text{C}$ the auxiliary field H_x will be $<3.0 \text{ kA/m}$; stable sensor operation may be threatened by disturbing magnetic fields.
2.
$$S = \frac{(V_O \text{ at } H_y = 1.6 \text{ kA/m}) - (V_O \text{ at } H_y = 0)}{1.6 \times V_{CC}}$$
3. The sensitivity increases and decreases linear with the supply voltage, thus the static output voltage is directly proportional to the supply voltage.
4. Sensor bridge response only. When sensing high speed rotation, the operating frequency may be reduced due to eddy current effects.

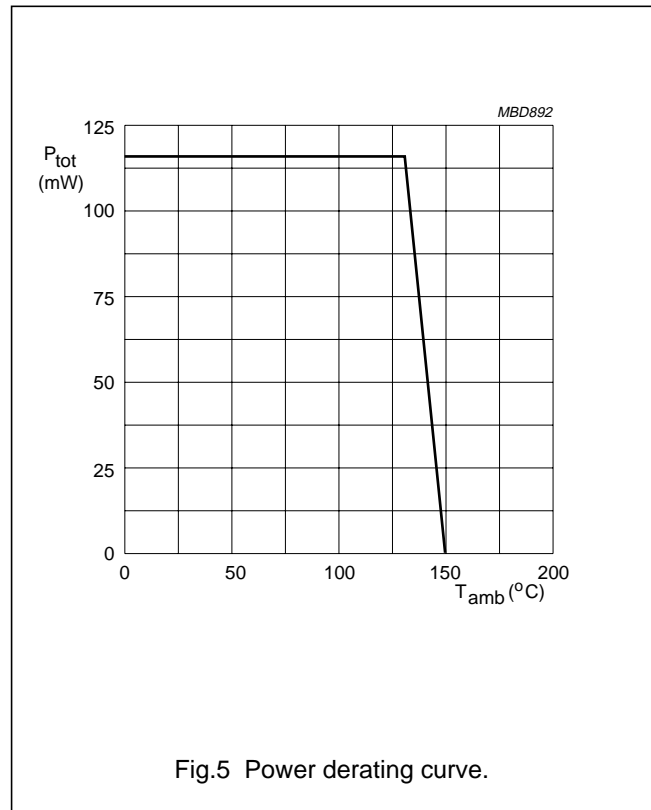
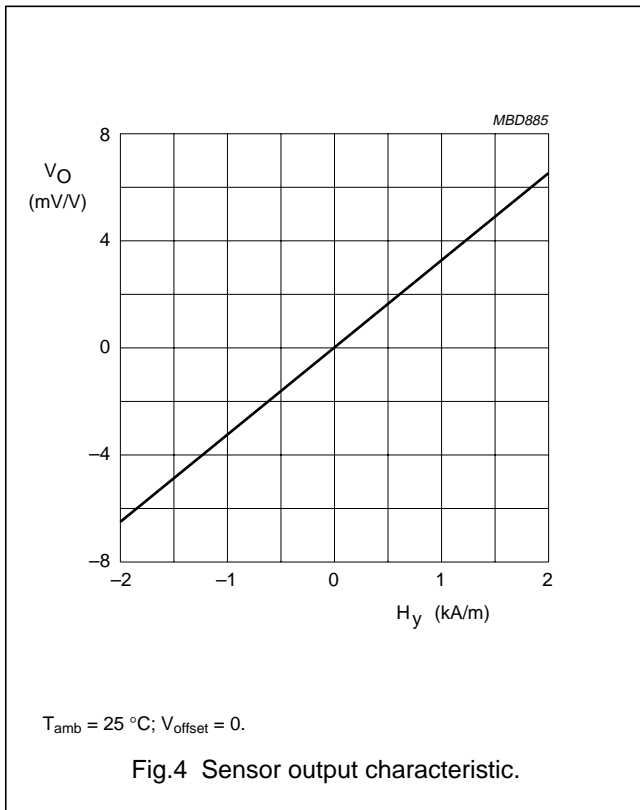
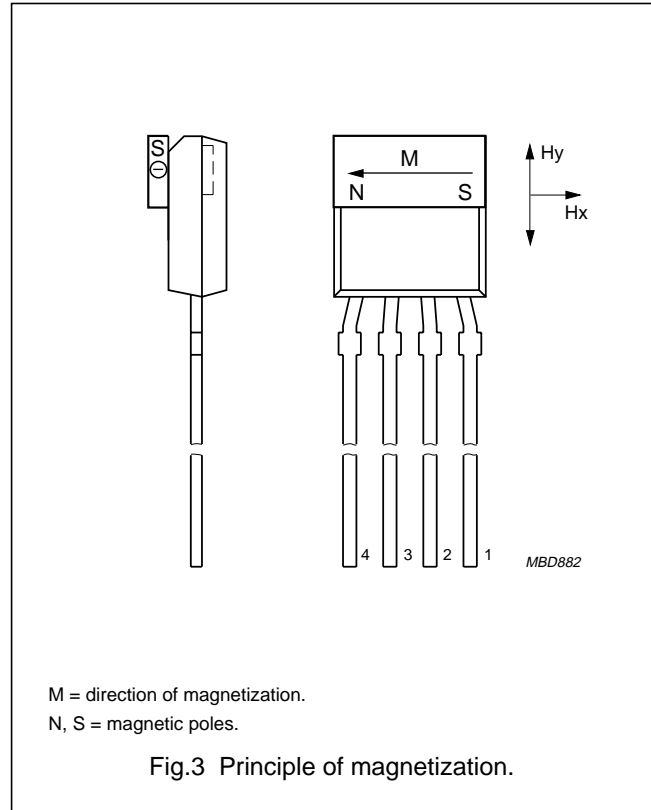

Magnetic field sensor

KM110B/2

PACKAGE OUTLINE

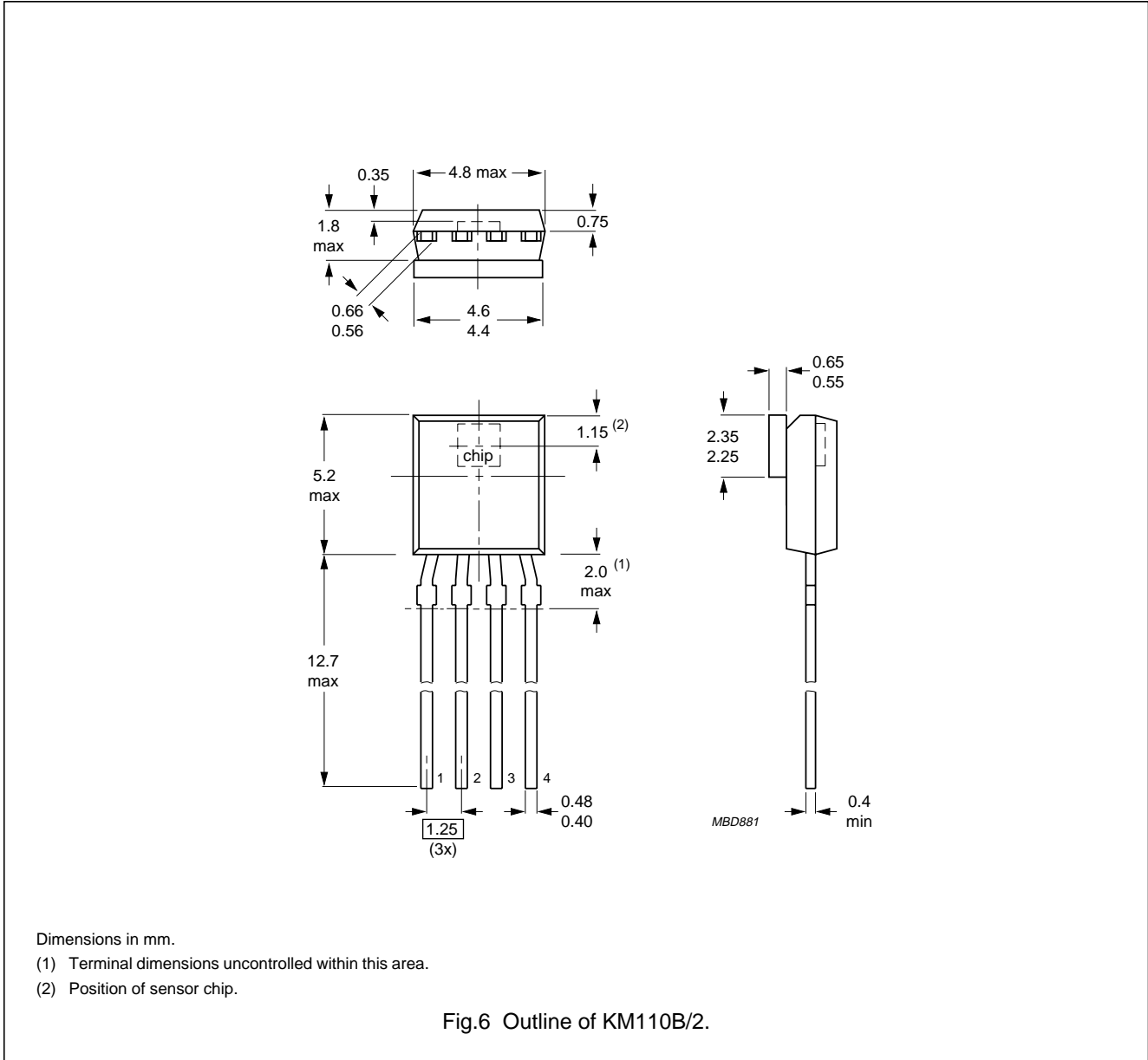

Magnetic field sensor

KM110B/2

DEFINITIONS

Data Sheet Status	
Objective specification	This data sheet contains target or goal specifications for product development.
Preliminary specification	This data sheet contains preliminary data; supplementary data may be published later.
Product specification	This data sheet contains final product specifications.
Limiting values	
Limiting values given are in accordance with the Absolute Maximum Rating System (IEC 134). Stress above one or more of the limiting values may cause permanent damage to the device. These are stress ratings only and operation of the device at these or at any other conditions above those given in the Characteristics sections of the specification is not implied. Exposure to limiting values for extended periods may affect device reliability.	
Application information	
Where application information is given, it is advisory and does not form part of the specification.	

LIFE SUPPORT APPLICATIONS

These products are not designed for use in life support appliances, devices, or systems where malfunction of these products can reasonably be expected to result in personal injury. Philips customers using or selling these products for use in such applications do so at their own risk and agree to fully indemnify Philips for any damages resulting from such improper use or sale.