

RoHS Compliant Product
A suffix of "-C" specifies halogen & lead-free

DESCRIPTION

KS05UL5 is an ultra-low capacitance TVS designed to protection for high-speed data interfaces. With typical capacitance of 0.6pF only, KS05UL5 is designed to protect parasitic-sensitive systems against over-voltage and over-current transient events.

KS05UL5 uses ultra-small DFN2510 package. Each KS05UL5 device can protect four high-speed data lines. The combined features of ultra-low capacitance, ultra-small size and high ESD robustness make KS05UL5 ideal for high-speed data ports and high-frequency lines (e.g., HDMI & DVI) applications. The low clamping voltage of the KS05UL5 guarantees a minimum stress on the protected IC.

APPLICATIONS

- PCI Express
- Desktops, Servers and Notebooks
- MDDI Ports
- USP 2.0/3.0 Power and Data Line Protection
- Display Ports
- High Definition Multi-Media Interface(HDMI)
- Digital Visual Interface(DVI)

MARKING

0524P

PACKAGE INFORMATION

Package	MPQ	Leader Size
DFN2510	3K	7 inch

DFN2510

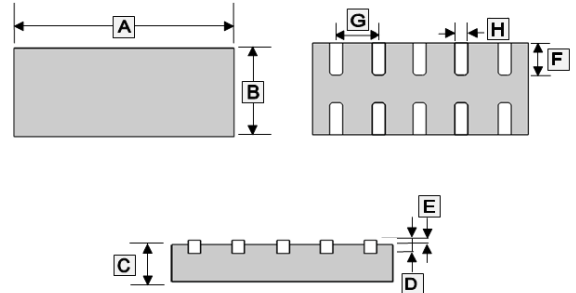

REF.	Millimeter		REF.	Millimeter	
	Min.	Max.		Min.	Max.
A	2.40	2.60	E	0.00	0.05
B	0.90	1.10	F	0.30	0.40
C	0.55TYP.		G	0.500 BSC.	
D	0.150 REF.		H	0.15	0.25

Pin Diagram

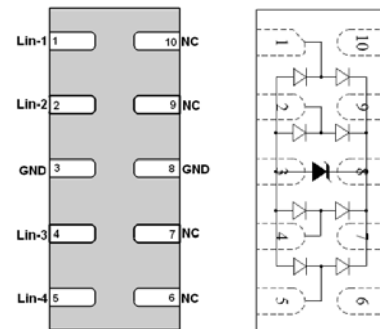

ABSOLUTE MAXIMUM RATINGS (T_A=25°C unless otherwise specified)

Parameter	Symbol	Value	Unit
IEC 61000-4-2 (ESD)	Air contact	±25	kV
	Contact discharge	±17	
Peak pulse power (tp=8/20us)	P _{PP}	30	W
Operating & Storage temperature range	T _J , T _{STG}	-55~125, -55~150	°C

ELECTRICAL CHARACTERISTICS (T_A=25°C unless otherwise specified)

Parameter	Symbol	Condition	Min.	Typ.	Max.	Units
Reverse Working Voltage	V _{RWM}	Any I/O-to-GND	-	-	5	V
Reverse Breakdown Voltage	V _{BR}	I _T =1mA, Any I/O-to-GND	6	8	10	V
Reverse Leakage Current	I _R	V _{RWM} =5V, Any I/O-to-GND	-	0.1	1	µA
Clamping Voltage	V _C	I _{PP} =1A, tp=8/20us, Any I/O-to-GND	-	-	12	V
Parasitic capacitance	C _{ESD}	I/O-to-GND, V _R =0, f=1MHz	-	0.6	0.8	pF
		I/O-to-I/O, V _R =0, f=1MHz	-	0.2	0.4	pF

Note: I/O pins are pin 1,2,4,5.

RATINGS AND CHARACTERISTICS CURVES

Voltage Sweeping of I/O to GND

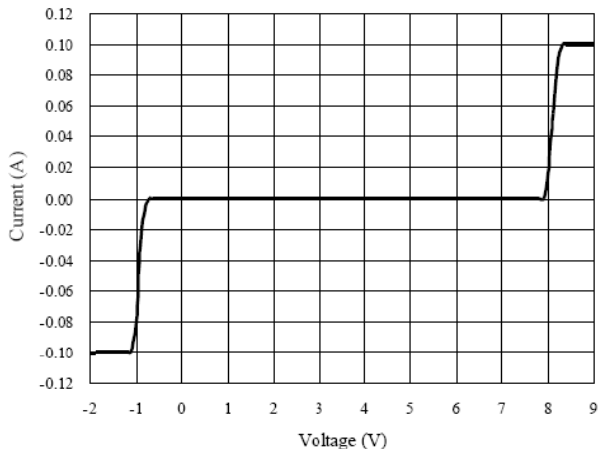

Insertion Loss S21 of I/O to GND

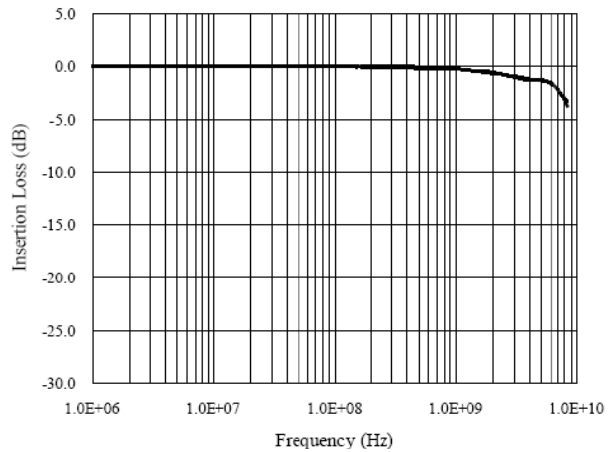

Capacitance vs. Voltage of I/O to GND (f = 1MHz)

Capacitance vs. Reverse Voltage

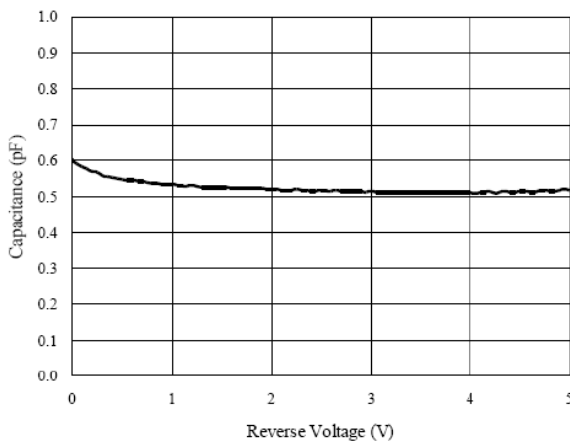

Normalized Capacitance vs. Reverse Voltage

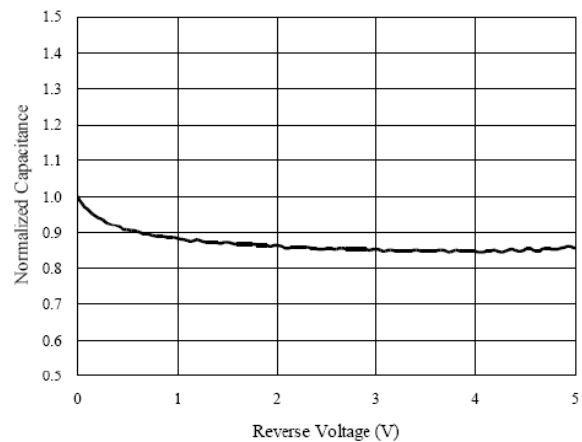

ESD Clamping of I/O to GND (+8kV Contact per IEC 61000-4-2)

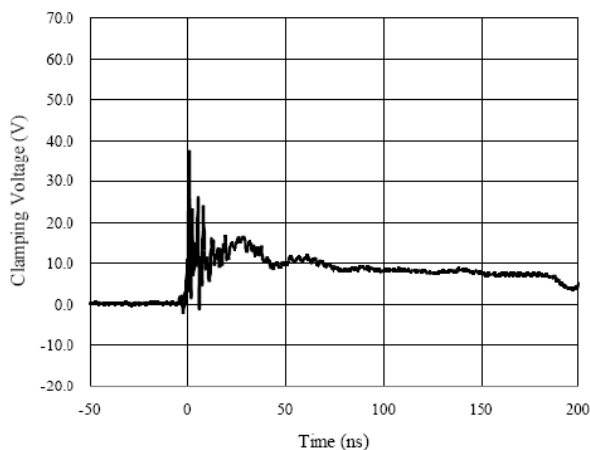

ESD Clamping of I/O to GND (-8kV Contact per IEC 61000-4-2)

