

# 1

## PRODUCT OVERVIEW

### OVERVIEW

The KS57C21116/C21124/C21132 single-chip CMOS microcontroller has been designed for high performance using Samsung's newest 4-bit CPU core, SAM47 (Samsung Arrangeable Microcontrollers).

With an up-to-1280-dot LCD direct drive capability, segment expandable circuit, 8-bit and 16-bit timer/counter, and serial I/O, the KS57C21116/C21124/C21132 offers an excellent design solution for a wide variety of applications which require LCD functions.

Up to 51 pins of the 128-pin QFP package can be dedicated to I/O. Nine vectored interrupts provide fast response to internal and external events. In addition, the KS57C21116/C21124/C21132's advanced CMOS technology provides for low power consumption and a wide operating voltage range.

### OTP

The KS57C21116/C21124/C21132 microcontroller is also available in OTP (One Time Programmable) version, KS57P21132. KS57P21132 microcontroller has an on-chip 32-Kbyte one-time-programmable EPROM instead of masked ROM. The KS57P21132 is comparable to KS57C21116/C21124/C21132, both in function and in pin configuration except ROM size.

## FEATURES SUMMARY

### Memory

- 3,584 × 4-bit RAM (Excluding LCD Display RAM)
- 16,384/24,576/32,768 × 8-bit ROM

### 51 I/O Pins

- I/O: 47 pins (32 pins are configurable as SEG pins)
- Input only: 4 pins

### LCD Controller/Driver

- 80 SEG × 16 COM, 88 SEG × 8 COM Terminals
- Internal resistor circuit for LCD bias
- 16 Level LCD contrast control (software)
- Segment expandable circuit
- All dot can be switched on/off

### 8-bit Basic Timer

- 4 interval timer functions
- Watch-dog timer

### 8-bit Timer/Counter

- Programmable 8-bit timer
- External event counter
- Arbitrary clock frequency output
- External clock signal divider

### 16-Bit Timer/Counter

- Programmable 16-bit timer
- External event counter
- Arbitrary clock frequency output
- External clock signal divider
- Configurable as two 8-bit Timers
- Serial I/O interface clock generator

### Watch Timer

- Time interval generation: 0.5 s, 3.9 ms at 32,768 Hz
- 4 frequency outputs to BUZ pin
- Clock source generation for LCD

### 8-bit Serial I/O Interface

- 8-bit transmit/receive mode
- 8-bit receive mode
- LSB-first or MSB-first transmission selectable
- Internal or external clock source

### Comparator

- 3 Channel mode: internal reference (4-bit resolution)
- 2 Channel mode: external reference

### Interrupts

- Five internal vectored interrupts
- Four external vectored interrupts
- Two quasi-interrupts

### Bit Sequential Carrier

- Supports 16-bit serial data transfer in arbitrary format

### Memory-Mapped I/O Structure

- Data memory bank 15

### Power-Down Modes

- Idle mode (only CPU clock stops)
- Stop mode (main system clock stops)
- Subsystem clock stop mode

### Oscillation Sources

- Crystal, Ceramic or RC for main system clock
- Crystal oscillator for subsystem clock
- Main system clock frequency: 0.4–6 MHz
- Subsystem clock frequency: 32.768 kHz
- CPU clock divider circuit (by 4, 8 or 64)

### Instruction Execution Times

- 0.67, 1.33, 10.7 μs at 6 MHz
- 0.95, 1.91, 15.3 μs at 4.19 MHz
- 122 μs at 32.768 kHz

### Operating Temperature

- –40 °C to 85 °C

### Operating Voltage Range

- 1.8 V to 5.5 V

### Package Type

- 128-pin QFP

## FUNCTION OVERVIEW

### SAM47 CPU

All KS57-series microcontrollers have the advanced SAM47 CPU core. The SAM47 CPU can directly address up to 32 K bytes of program memory. The arithmetic logic unit (ALU) performs 4-bit addition, subtraction, logical, and shift-and-rotate operations in one instruction cycle and most 8-bit arithmetic and logical operations in two cycles.

### CPU REGISTERS

#### Program Counter

A 15-bit program counter (PC) stores addresses for instruction fetches during program execution. Usually, the PC is incremented by the number of bytes of the fetched instruction. The one instruction fetch that does not increment the PC is the 1-byte REF instruction which references instructions stored in a look-up table in the ROM. Whenever a reset operation or an interrupt occurs, bits PC13 through PC0 are set to the vector address.

#### Stack Pointer

An 8-bit stack pointer (SP) stores addresses for stack operations. The stack area is located in general-purpose data memory bank 0. The SP is 8-bit read/writeable and SP bit 0 must always be logical zero. During an interrupt or a subroutine call, the PC value and the PSW are written to the stack area. When the service routine has completed, the values referenced by the stack pointer are restored. Then, the next instruction is executed.

The stack pointer can access the stack despite data memory access enable flag status. Since the reset value of the stack pointer is not defined in firmware, you use program code to initialize the stack pointer to 00H. This sets the first register of the stack area to data memory location 0FFH.

### PROGRAM MEMORY

In its standard configuration, the 16,384/24,576/32,768 × 8-bit ROM is divided into four areas:

- 16-byte area for vector addresses
- 96-byte instruction reference area
- 16-byte general-purpose area (0010–001FH)
- 16,256/24,448/32,640-byte area for general-purpose program memory

The vector address area is used mostly during reset operations and interrupts. These 16 bytes can alternately be used as general-purpose ROM.

The REF instruction references 2 × 1-byte or 2-byte instructions stored in reference area locations 0020H–007FH. REF can also reference three-byte instructions such as JP or CALL. So that a REF instruction can reference these instructions, however, the JP or CALL must be shortened to a 2-byte format. To do this, JP or CALL is written to the reference area with the format TJP or TCALL instead of the normal instruction name. Unused locations in the REF instruction look-up area can be allocated to general-purpose use.

## DATA MEMORY

### Overview

The 3,584-bit data memory has five areas:

- 32 × 4-bit working register area
- 224 × 4-bit general-purpose area in bank 0 which is also used as the stack area
- 256 × 4-bit general-purpose area in bank 1, bank 2, ....., bank 13, respectively
- 256 × 5-bit area for LCD data in bank 14
- 128 × 4-bit area in bank 15 for memory-mapped I/O addresses

The data memory area is also organized as sixteen memory banks — bank 0, bank 1, ....., and bank 15. You use the select memory bank instruction (SMB) to select one of the banks as working data memory.

Data stored in RAM locations are 1-, 4-, and 8-bit addressable. After a hardware reset, data memory initialization values must be defined by program code.

### Data Memory Addressing Modes

The enable memory bank (EMB) flag controls the addressing mode for data memory banks 0, 1, ....., or 15. When the EMB flag is logical zero, only locations 00H–7FH of bank 0 and bank 15 can be accessed. When the EMB flag is set to logical one, all sixteen data memory banks can be accessed based on the current SMB value.

### Working Registers

The RAM's working register area in data memory bank 0 is also divided into four *register* banks. Each register bank has eight 4-bit registers. Paired 4-bit registers are 8-bit addressable.

Register A can be used as a 4-bit accumulator and double register EA as an 8-bit extended accumulator; double registers WX, WL and HL are used as address pointers for indirect addressing.

To limit the possibility of data corruption due to incorrect register addressing, it is advisable to use bank 0 for main programs and banks 1, 2, and 3 for interrupt service routines.

### LCD Data Register Area

Bit values for LCD segment data are stored in data memory bank 14. Register locations that are not used to store LCD data can be assigned to general-purpose use.

### Bit Sequential Carrier

The bit sequential carrier (BSC) is a 16-bit general register that you can manipulate using 1-, 4-, and 8-bit RAM control instructions.

Using the BSC register, addresses and bit locations can be specified sequentially using 1-bit indirect addressing instructions. In this way, a program can generate 16-bit data output by moving the bit location sequentially, incrementing or decrementing the value of the L register. You can also use direct addressing to manipulate data in the BSC.

## CONTROL REGISTERS

### Program Status Word

The 8-bit program status word (PSW) controls ALU operations and instruction execution sequencing. It is also used to restore a program's execution environment when an interrupt has been serviced. Program instructions can always address the PSW regardless of the current value of data memory access enable flags. Before an interrupt is processed, the PSW is pushed onto the stack in data memory bank 0. When the routine is completed, PSW values are restored.

IS1	IS0	EMB	ERB
C	SC2	SC1	SC0

Interrupt status flags (IS1, IS0), the enable memory bank and enable register bank flags (EMB, ERB), and the carry flag (C) are 1- and 4-bit read/write or 8-bit read-only addressable. Skip condition flags (SC0–SC2) can be addressed using 8-bit read instructions only.

### Select Bank (SB) Register

Two 4-bit locations called the SB register store address values used to access specific memory and register banks: the select memory bank register, SMB, and the select register bank register, SRB. 'SMB n' instructions select a data memory bank (0, 1, ....., or 15) and store the upper four bits of the 12-bit data memory address in the SMB register. The 'SRB n' instruction is used to select register bank 0, 1, 2, or 3, and to store the address data in the SRB. The instructions 'PUSH SB' and 'POP SB' move SMB and SRB values to and from the stack for interrupts and subroutines.

## CLOCK CIRCUITS

Main system and subsystem oscillation circuits generate the internal clock signals for the CPU and peripheral hardware. The main system clock can use a Crystal, Ceramic, or RC oscillation source, or an externally-generated clock signal. The subsystem clock requires either a crystal oscillator or an external clock source. Bit settings in the 4-bit power control and system clock mode registers select the oscillation source, the CPU clock, and the clock used during power-down mode. The internal system clock signal (f<sub>xx</sub>) can be divided internally to produce four CPU clock frequencies — f<sub>x</sub>/4, f<sub>x</sub>/8, f<sub>x</sub>/64, or f<sub>xt</sub>/4.

## INTERRUPTS

Interrupt requests may be generated internally by on-chip processes (INTB, INTT0, INTT1, and INTS) or externally by peripheral devices (INT0, INT1, INT4, and INTK). There are two quasi-interrupts: INT2 and INTW. INT2 detects rising or falling edges of incoming signals and INTW detects time intervals of 0.5 seconds or 3.91 milliseconds. The following components support interrupt processing:

- Interrupt enable flags
- Interrupt request flags
- Interrupt priority registers
- Power-down termination circuit

## POWER DOWN

To reduce power consumption, there are two power-down modes: idle and stop. The IDLE instruction initiates idle mode and the STOP instruction initiates stop mode.

In idle mode, only the CPU clock stops while peripherals and the oscillation source continue to operate normally. Stop mode effects only the main system clock — a subsystem clock, if used, continues oscillating. In stop mode, main system clock oscillation stops completely, halting all operations except for a few basic peripheral functions. RESET or an interrupt can be used to terminate either idle or stop mode.

## RESET

When a RESET signal occurs during normal operation or during power-down mode, the CPU enters idle mode when the reset operation is initiated. When the standard oscillation stabilization interval (31.3 ms at 4.19 MHz) has elapsed, normal CPU operation resumes.

## I/O PORTS

The KS57C21116/C21124/C21132 has 13 I/O ports. Pin addresses for all I/O ports are mapped in bank 15 of the RAM. There are 4 input pins and 47 configurable I/O pins for a total of 51 I/O pins. The contents of I/O port pin latches can be read, written, or tested at the corresponding address using bit manipulation instructions.

## TIMERS and TIMER/COUNTERS

The timer function has four main components: an 8-bit basic interval timer, an 8-bit timer/counter, a 16-bit timer/counter and a watch timer. The 8-bit basic timer generates interrupt requests at precise intervals, based on the selected clock frequency and has watch-dog timer function.

The programmable 8-bit and 16-bit timer/counters are used for external event counting, generation of arbitrary clock frequencies for output, and dividing external clock signals. The 16-bit timer/counter is the source of the clock signal that is required to drive the serial I/O interface and configurable as two 8-bit timer/counters.

The watch timer has an 8-bit watch timer mode register, a clock selector and a frequency divider circuit. Its functions include real-time and watch-time measurement, clock generation for the LCD controller and frequency outputs for buzzer sound.

## LCD DRIVER/CONTROLLER

The KS57C21116/C21124/C21132 can directly drive an up-to-1,280-dot LCD panel. The LCD function block has the following components:

- RAM area for storing display data
- 80 segment output pins (SEG0–SEG79)
- Segment expandable circuit
- 16 common output pins (COM0–COM15)
- 5 operating power supply pins ( $V_{LC1}$ – $V_{LC5}$ )
- Sixteen level LCD contrast control circuit (software)

Frame frequency, LCD clock, duty, and segment pins used for display output are controlled by bit settings in the 8-bit mode register, LMOD. You use the 4-bit LCD control register, LCON, to turn the LCD display on and off, and to control current supplied to the dividing resistors. Segment data are output using a direct memory access method synchronized with the LCD frame frequency ( $f_{LCD}$ ).

Using the main system clock, the LCD panel operates in idle mode; during stop mode, it is turned off. If a subsystem clock is used as a clock source, the LCD panel will continue to operate during stop and idle modes.

## SERIAL I/O INTERFACE

The serial I/O interface supports the transmission or reception of 8-bit serial data with an external device. The serial interface has the following functional components:

- 8-bit mode register
- Clock selector circuit
- 8-bit buffer register
- 3-bit serial clock counter

The serial I/O circuit can be set either to transmit-and-receive or to receive-only mode. MSB-first or LSB-first transmission is also selectable. The serial interface operates with an internal or an external clock source, or using the clock signal generated by the 16-bit timer/counter. To modify transmission frequency, the appropriate bits in the serial I/O mode register (SMOD) must be manipulated.

## COMPARATOR

Port 4 can be used as an analog input port for a comparator. The reference voltage for the 3-channel comparator can be supplied either internally or externally at P4.2. The comparator module has the following components:

- Comparator
- Internal reference voltage generator (4-bit resolution)
- External reference voltage source at P4.2
- Comparator mode register (CMOD)
- Comparison result register (CMPREG)

BLOCK DIAGRAM

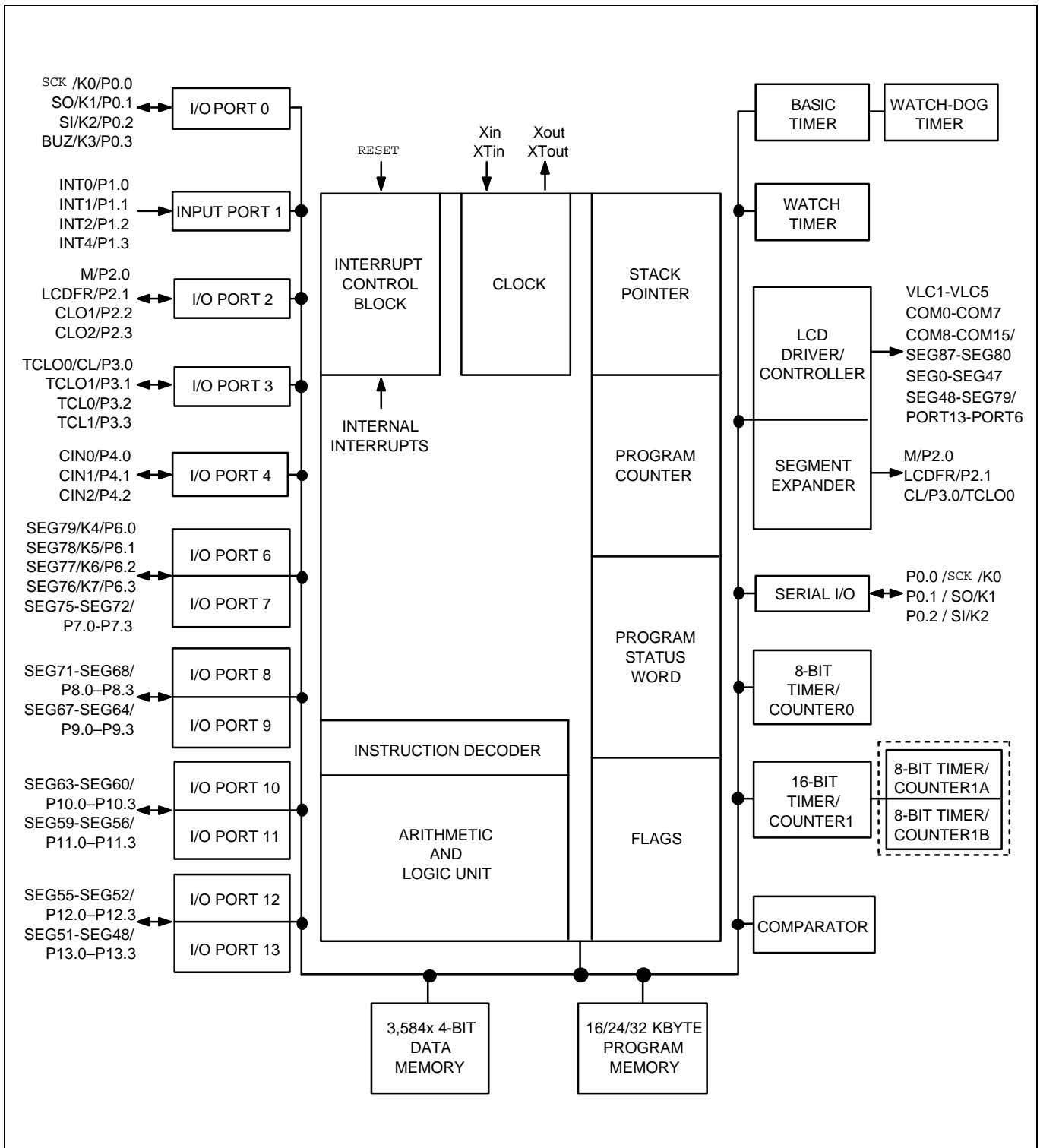

Figure 1-1. KS57C21116/C21124/C21132 Simplified Block Diagram





**PIN DESCRIPTIONS**

**Table 1-1. KS57C21116/C21124/C21132 Pin Descriptions**

Pin Name	Pin Type	Description	Number	Share Pin
P0.0 P0.1 P0.2 P0.3	I/O	4-bit I/O port. 1-bit and 4-bit read/write and test is possible. 4-bit unit pull-up resistors are assignable to input pins by software and are automatically disabled for output pins. Each bit pin can be allocated as input or output (1-bit unit). The N-ch open drain or push-pull output may be selected by software (1-bit unit).	16 17 18 19	SCK/K0 SO/K1 SI/K2 BUZ/K3
P1.0 P1.1 P1.2 P1.3	I	4-bit input port. 1-bit and 4-bit read and test is possible. 4-bit unit pull-up resistors are assignable to input pins by software.	28 29 30 31	INT0 INT1 INT2 INT4
P2.0 P2.1 P2.2 P2.3	I/O	4-bit I/O port. 1-bit and 4-bit read/write and test is possible. I/O function is same as port 0.	32 33 34 35	M LCDFR CLO1 CLO2
P3.0 P3.1 P3.2 P3.3	I/O	4-bit I/O port. 1-bit and 4-bit read/write and test is possible. I/O function is same as port 0.	36 37 38 39	TCLO0/CL TCLO1 TCL0 TCL1
P4.0 P4.1 P4.2	I/O	3-bit I/O port. I/O function is same as port 0 except that port 4 is 3-bit I/O port.	40 41 42	CIN0 CIN1 CIN2
P6.0 P6.1 P6.2 P6.3 P7.0–P7.3	I/O	4-bit I/O port. 1-, 4-bit and 8-bit read/write and test is possible. 4-bit unit pull-up resistors are assignable to input pins by software and are automatically disabled for output pins. Each bit pin can be allocated as input or output (1-bit unit). The N-ch open drain or push-pull output may be selected by software (4-bit unit).	43 44 45 46 47–50	K4/SEG79 K5/SEG78 K6/SEG77 K7/SEG76 SEG75–72
P8.0–P8.3 P9.0–P9.3	I/O	4-bit I/O port. 1-, 4-bit and 8-bit read/write and test is possible. I/O function is same as port 6, 7.	51–54 55–58	SEG71–68 SEG67–64
P10.0–P10.3 P11.0–P11.3	I/O	4-bit I/O port. 1-, 4-bit and 8-bit read/write and test is possible. I/O function is same as port 6, 7.	59–62 63–66	SEG63–60 SEG59–56
P12.0–P12.3 P13.0–P13.3	I/O	4-bit I/O port. 1-, 4-bit and 8-bit read/write and test is possible. I/O function is same as port 6, 7.	67–70 71–74	SEG55–52 SEG51–48
SCK	I/O	Serial I/O interface clock signal	16	P0.0
SO	I/O	Serial data output	17	P0.1
SI	I/O	Serial data input	18	P0.2
BUZ	I/O	2, 4, 8, 16 kHz frequency output for buzzer sound	19	P0.3
K0–K3 K4–K7	I/O	External interrupts with rising/falling edge detection	16–19 43–46	P0.0–P0.3 P6.0–P6.3

Table 1-1. KS57C21116/C21124/C21132 Pin Descriptions (Continued)

Pin Name	Pin Type	Description	Number	Share Pin
INT0	I	External interrupts with rising/falling edge detection	28	P1.0
INT1	I	External interrupts with rising/falling edge detection	29	P1.1
INT2	I	External quasi-interrupts with rising/falling edge detection	30	P1.2
INT4	I	External interrupts with rising/falling edge detection	31	P1.3
M	I/O	Alternated signal for SEG driver	32	P2.0
LCDFR	I/O	Synchronous frame signal for SEG driver	33	P2.1
CLO1	I/O	Clock output or operating clock for SEG driver	34	P2.2
CLO2	I/O	Clock output or operating clock for SEG driver	35	P2.3
CL	I/O	Data shift clock for SEG driver	36	P3.0
TCLO0	I/O	Timer/counter0 clock output	36	P3.0
TCLO1	I/O	Timer/counter1 clock output	37	P3.1
TCL0	I/O	External clock input for timer/counter 0	38	P3.2
TCL1	I/O	External clock input for timer/counter 1	39	P3.3
CIN0–CIN2	I/O	CIN0,1: comparator input only CIN2: comparator input or external reference input	40, 41 42	P4.0–P4.1 P4.2
SEG0–SEG47	O	LCD segment data output	122–75	–
SEG48–SEG79	O	LCD segment data output	74–43	Port13–6
SEG80–SEG87	O	LCD segment data output	2,1, 128–123	COM15–8
COM0–COM7	O	LCD common data output	10–3	–
COM8–COM15	O	LCD common data output	123–128 1, 2	SEG87–80
V <sub>LC1</sub> –V <sub>LC5</sub>	–	LCD power supply. Voltage dividing resistors are fixed.	15–11	–
V <sub>DD</sub>	–	Main power supply	20	–
V <sub>SS</sub>	–	Ground	21	–
X <sub>in</sub> , X <sub>out</sub>	–	Crystal, Ceramic, or RC oscillator signal I/O for main system clock.	23, 22	–
X <sub>Tin</sub> , X <sub>Tout</sub>	–	Crystal oscillator signal I/O for subsystem clock.	25, 26	–
TEST	I	Test signal input (must be connected to V <sub>SS</sub> )	24	–
RESET	I	Reset signal	27	–

**NOTE:** Pull-up resistors for all I/O ports are automatically disabled if they are configured to output mode.

Table 1-2. Overview of KS57C21116/C21124/C21132 Pin Data

Pin Names	Share Pins	I/O Type	Reset Value	Circuit Type
P0.0–P0.3	SCK, SO, SI, BUZ/K0–K3	I/O	Input	E-2
P1.0–P1.3	INT0–INT2, INT4	I	Input	A-3
P2.0–P2.3	M, LCDFR, CLO1, CLO2	I/O	Input	E
P3.0–P3.1	TCLO0/CL, TCLO1	I/O	Input	E
P3.2–P3.3	TCL0, TCL1	I/O	Input	E-1
P4.0–P4.2	CIN0–CIN2	I/O	Input	F-4
P6.0–P6.3	K4–K7/SEG79–SEG76	I/O	Input	H-15
P7.0–P7.3	SEG75–SEG72	I/O	Input	H-8
P8.0–P8.3	SEG71–SEG68	I/O	Input	H-8
P9.0–P9.3	SEG67–SEG64	I/O	Input	H-8
P10.0–P10.3	SEG63–SEG60	I/O	Input	H-8
P11.0–P11.3	SEG59–SEG56	I/O	Input	H-8
P12.0–P12.3	SEG55–SEG52	I/O	Input	H-8
P13.0–P13.3	SEG51–SEG48	I/O	Input	H-8
COM0–COM7	–	O	Low output	H-4
COM8–COM15	SEG87–SEG80	O	Low output	H-6
SEG0–SEG47	–	O	Low output	H-5
$V_{LC1}$ – $V_{LC5}$	–	–	–	–
$V_{DD}$	–	–	–	–
$V_{SS}$	–	–	–	–
$X_{IN}$ , $X_{OUT}$	–	–	–	–
$XT_{IN}$ , $XT_{OUT}$	–	–	–	–
RESET	–	I	–	B
TEST	–	I	–	–

**PIN CIRCUIT DIAGRAMS**

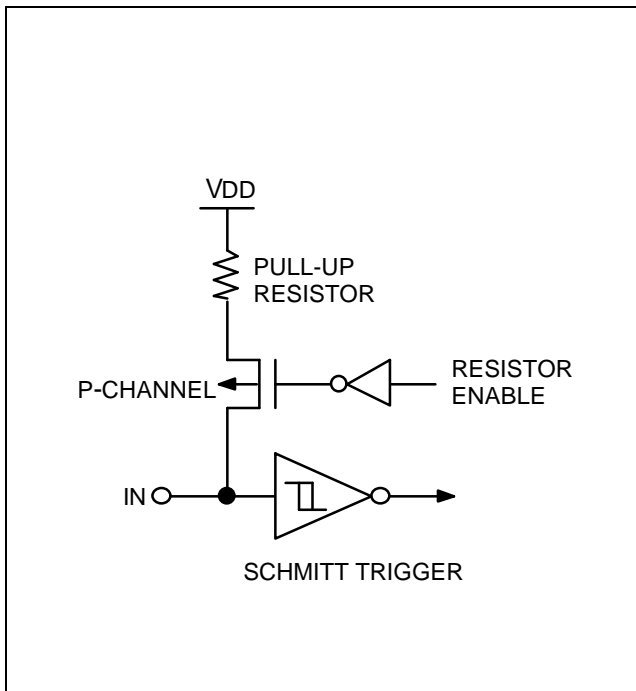

**Figure 1-3. Pin Circuit Type A-3**

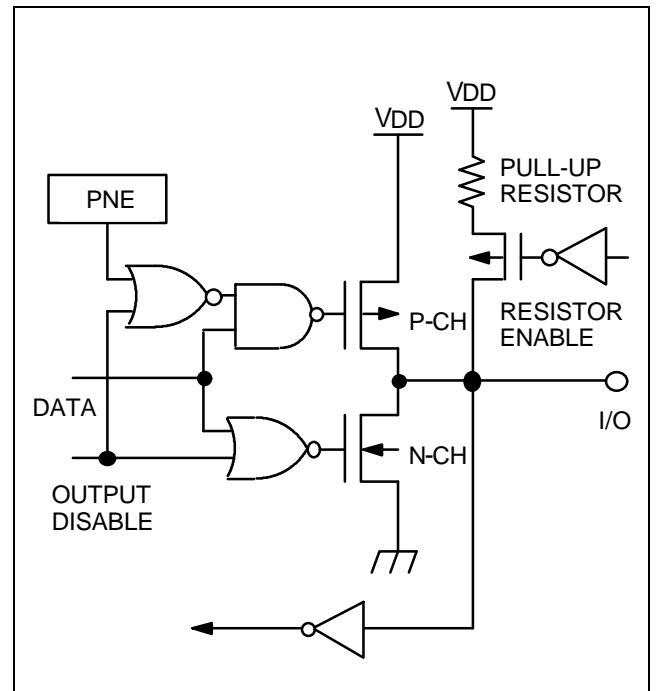

**Figure 1-5. Pin Circuit Type E**

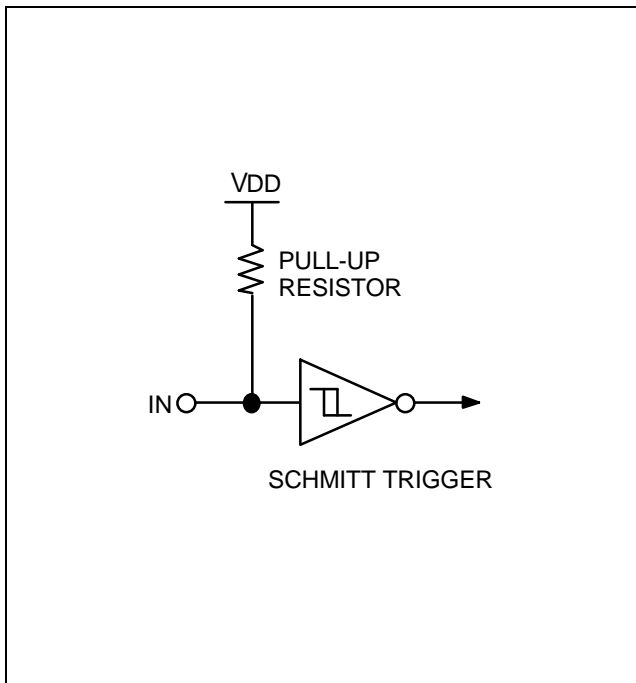

**Figure 1-4. Pin Circuit Type B**

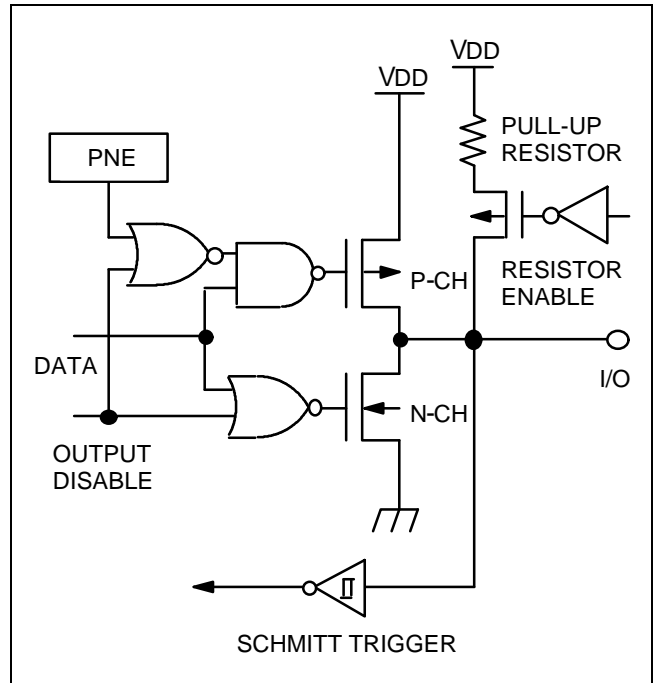

**Figure 1-6. Pin Circuit Type E-1**

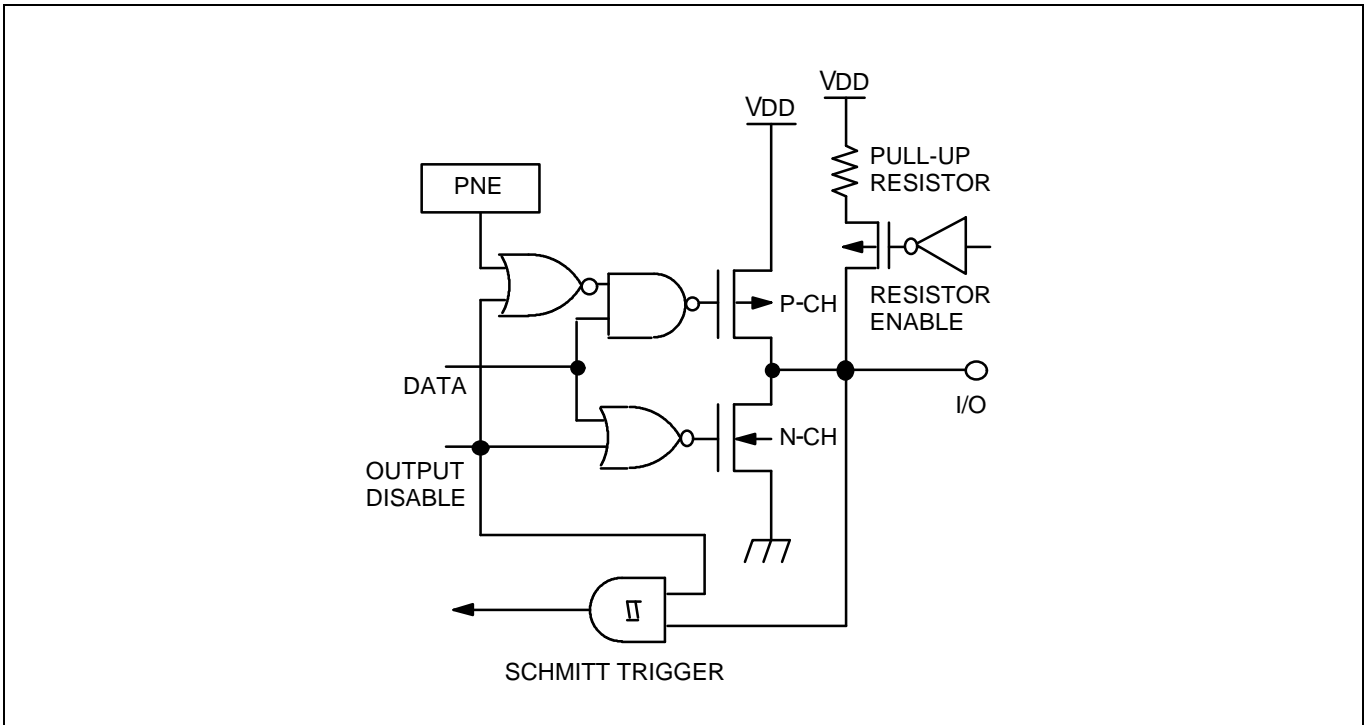

Figure 1-7. Pin Circuit Type E-2

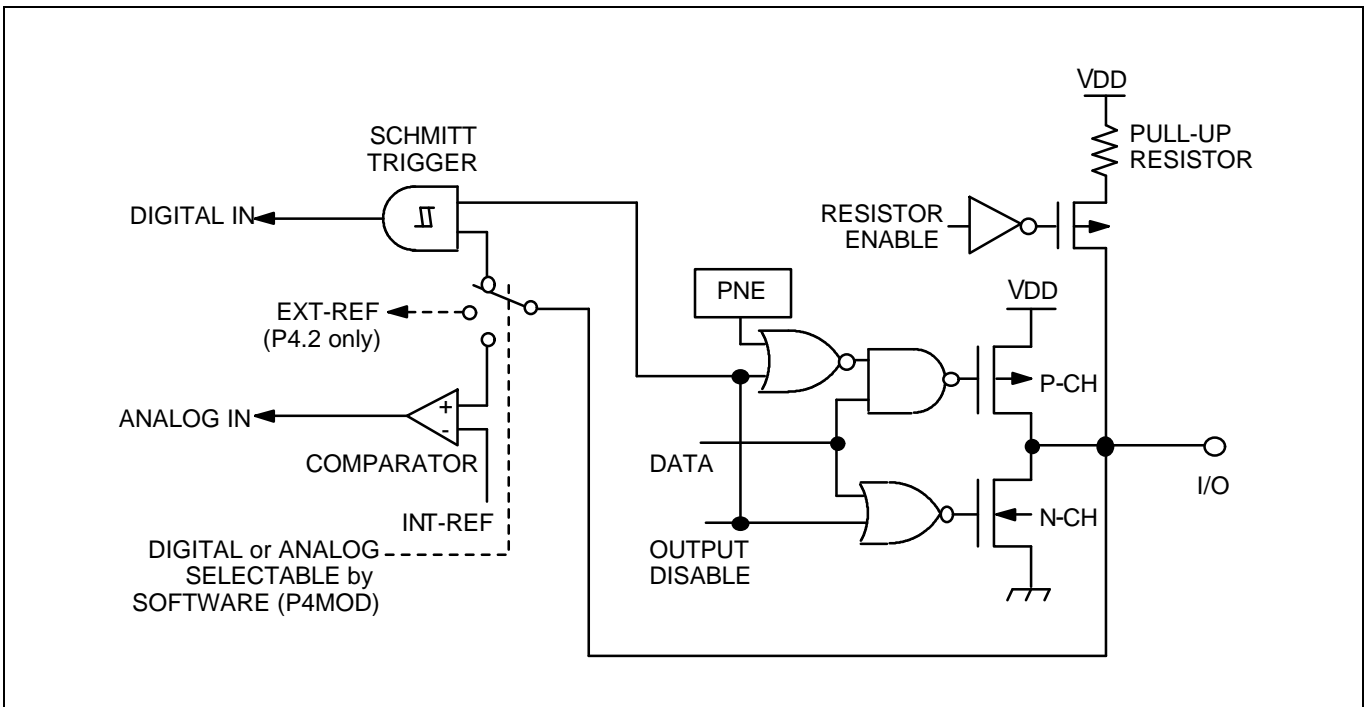

Figure 1-8. Pin Circuit Type F-4

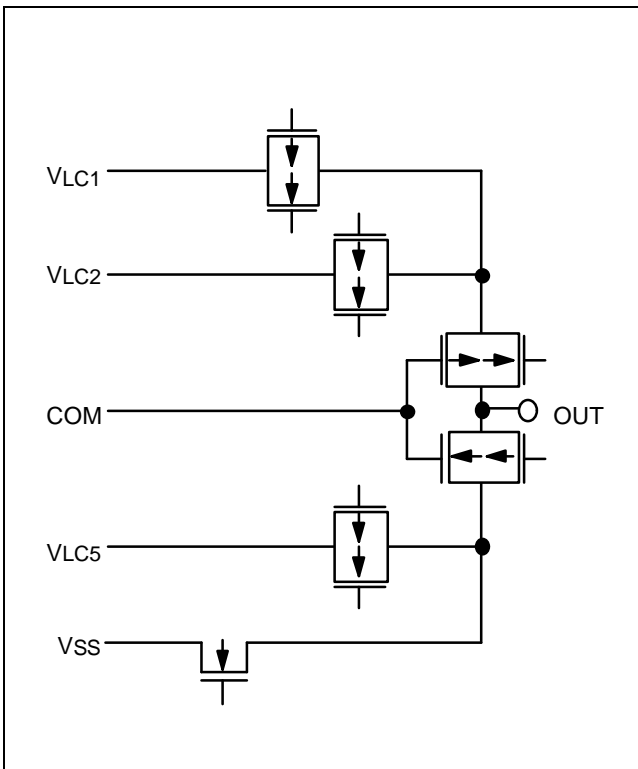

Figure 1-9. Pin Circuit Type H-4

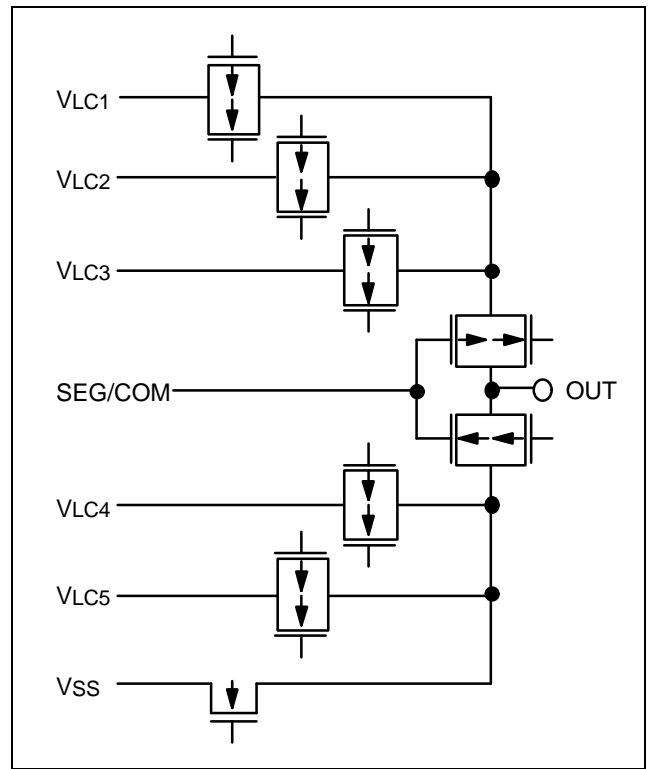

Figure 1-11. Pin Circuit Type H-6

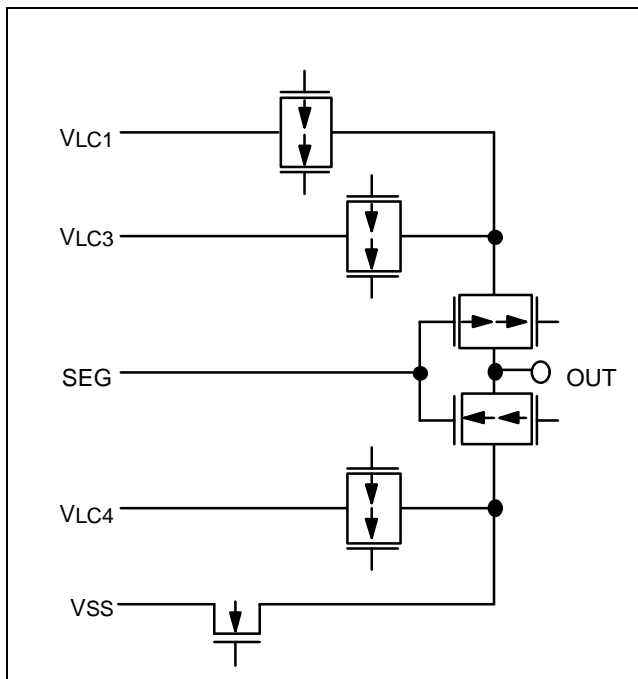

Figure 1-10. Pin Circuit Type H-5

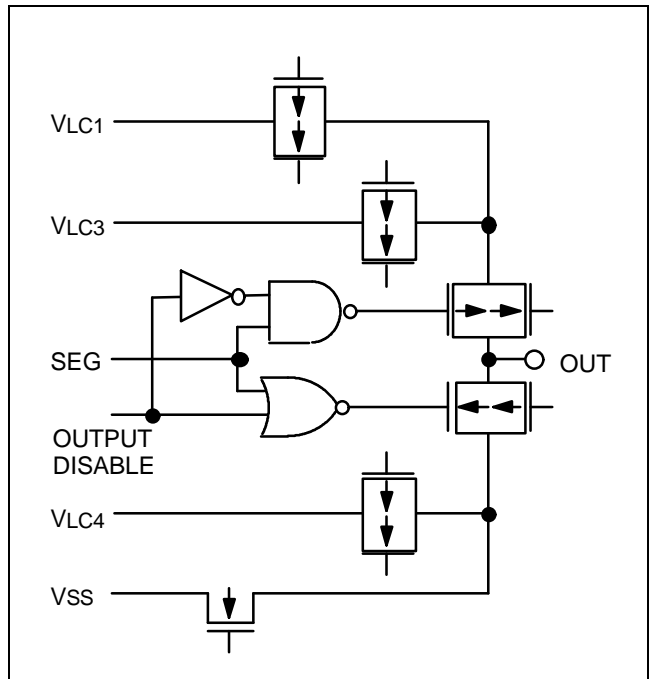

Figure 1-12. Pin Circuit Type H-7

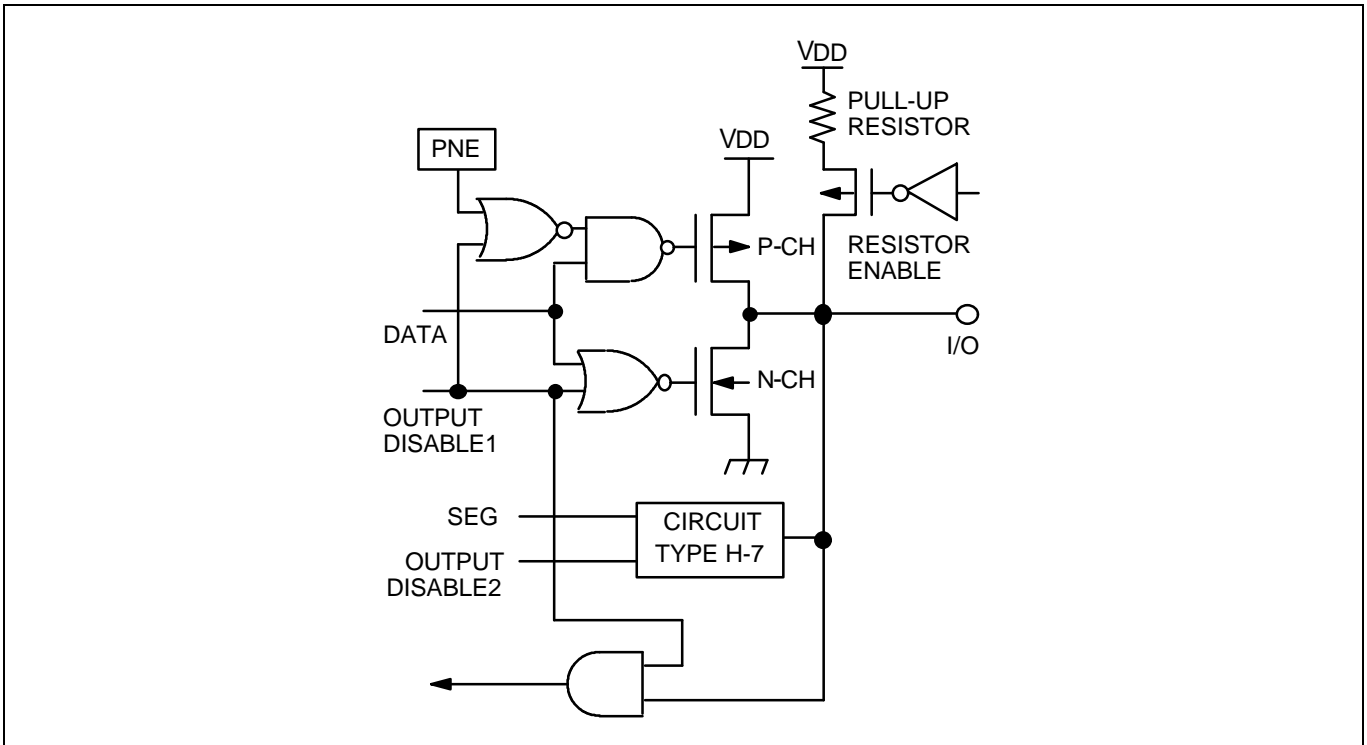

Figure 1-13. Pin Circuit Type H-8

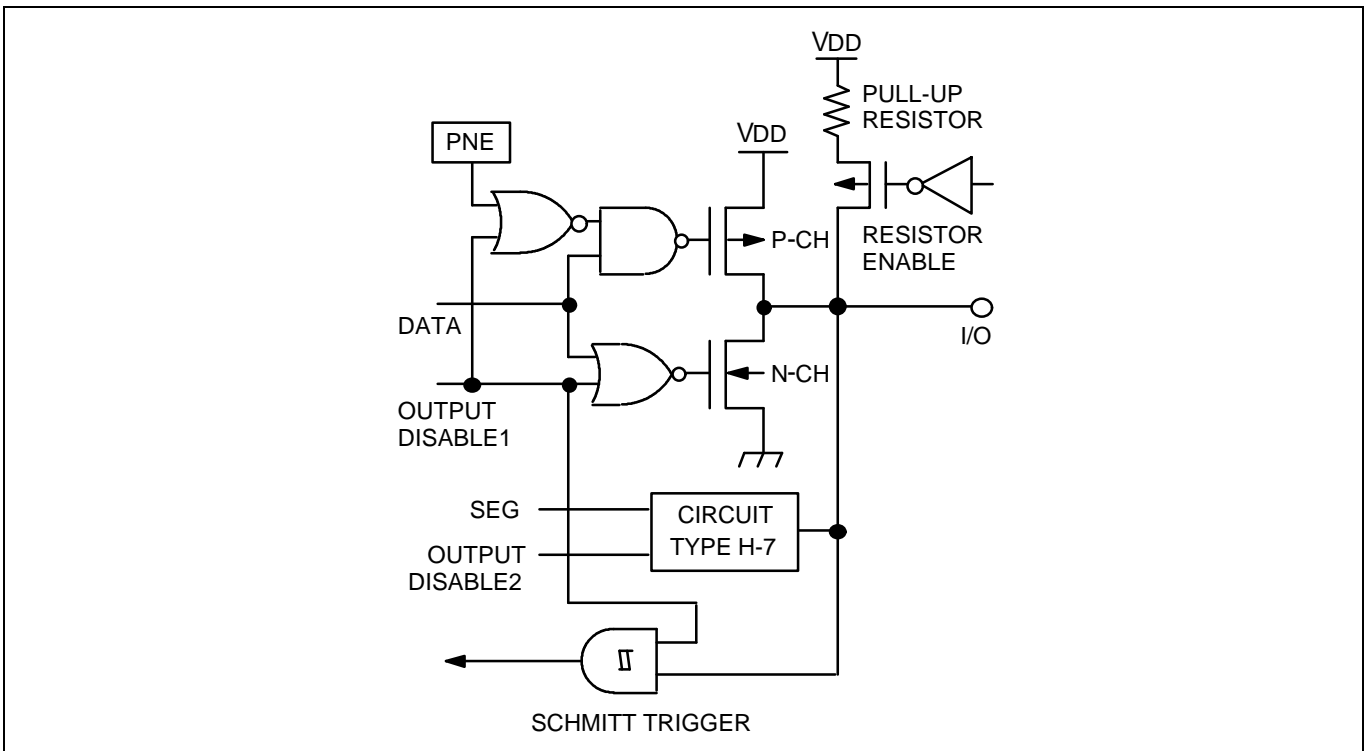

Figure 1-14. Pin Circuit Type H-15



# 15 ELECTRICAL DATA

## OVERVIEW

In this section, information on KS57C21116/C21124/C21132 electrical characteristics is presented as tables and graphics. The information is arranged in the following order:

### Standard Electrical Characteristics

- Absolute maximum ratings
- D.C. electrical characteristics
- Main system clock oscillator characteristics
- Subsystem clock oscillator characteristics
- I/O capacitance
- Comparator electrical characteristics
- LCD contrast controller characteristics
- A.C. electrical characteristics
- Operating voltage range

### Stop Mode Characteristics and Timing Waveforms

- RAM data retention supply voltage in stop mode
- Stop mode release timing when initiated by RESET
- Stop mode release timing when initiated by an interrupt request

### Miscellaneous Timing Waveforms

- A.C timing measurement points
- Clock timing measurement at  $X_{in}$
- Clock timing measurement at  $XT_{in}$
- TCL0/TCL1 timing
- Input timing for RESET signal
- Input timing for external interrupts and quasi-interrupts
- Serial data transfer timing

Table 15-1. Absolute Maximum Ratings

(T<sub>A</sub> = 25 °C)

Parameter	Symbol	Conditions	Rating	Units
Supply Voltage	V <sub>DD</sub>	–	– 0.3 to + 6.5	V
Input Voltage	V <sub>I</sub>	All I/O pins active	– 0.3 to V <sub>DD</sub> + 0.3	V
Output Voltage	V <sub>O</sub>	–	– 0.3 to V <sub>DD</sub> + 0.3	V
Output Current High	I <sub>OH</sub>	One I/O pin active	– 15	mA
		All I/O pins active	– 35	
Output Current Low	I <sub>OL</sub>	One I/O pin active	+ 30 (Peak value)	mA
			+ 15 *	
		Total for ports 0, 2–9	+ 100 (Peak value)	
			+ 60 *	
Operating Temperature	T <sub>A</sub>	–	– 40 to + 85	°C
Storage Temperature	T <sub>stg</sub>	–	– 65 to + 150	°C

\* The values for Output Current Low ( I<sub>OL</sub> ) are calculated as Peak Value × √Duty .

Table 15-2. D.C. Electrical Characteristics

(T<sub>A</sub> = – 40 °C to + 85 °C, V<sub>DD</sub> = 1.8 V to 5.5 V)

Parameter	Symbol	Conditions	Min	Typ	Max	Units
Input High Voltage	V <sub>IH1</sub>	All input pins except those specified below for V <sub>IH2</sub> –V <sub>IH3</sub>	0.7 V <sub>DD</sub>	–	V <sub>DD</sub>	V
	V <sub>IH2</sub>	Ports 0, 1, 4, 6, P3.2, P3.3, and RESET	0.8 V <sub>DD</sub>		V <sub>DD</sub>	
	V <sub>IH3</sub>	X <sub>in</sub> , X <sub>out</sub> , XT <sub>in</sub> , and XT <sub>out</sub>	V <sub>DD</sub> – 0.1		V <sub>DD</sub>	
Input Low Voltage	V <sub>IL1</sub>	All input pins except those specified below for V <sub>IL2</sub> –V <sub>IL3</sub>	–	–	0.3 V <sub>DD</sub>	V
	V <sub>IL2</sub>	Ports 0, 1, 4, 6, P3.2, P3.3, and RESET			0.2 V <sub>DD</sub>	
	V <sub>IL3</sub>	X <sub>in</sub> , X <sub>out</sub> , XT <sub>in</sub> , and XT <sub>out</sub>			0.1	
Output High Voltage	V <sub>OH</sub>	V <sub>DD</sub> = 4.5 V to 5.5 V I <sub>OH</sub> = – 1 mA Ports 0, 2, 3, 4, ports 6–13	V <sub>DD</sub> – 1.0	–	–	V
Output Low Voltage	V <sub>OL</sub>	V <sub>DD</sub> = 4.5 V to 5.5 V I <sub>OL</sub> = 15 mA Ports 0, 2, 3, 4, ports 6–13	–	–	2.0	V
		V <sub>DD</sub> = 1.8 V to 5.5 V I <sub>OL</sub> = 1.6 mA			0.4	

Table 15-2. D.C. Electrical Characteristics (Continued)

 $(T_A = -40\text{ }^\circ\text{C to } +85\text{ }^\circ\text{C, } V_{DD} = 1.8\text{ V to } 5.5\text{ V})$ 

Parameter	Symbol	Conditions	Min	Typ	Max	Units
Input High Leakage Current	$I_{LH1}$	$V_I = V_{DD}$ All input pins except those specified below for $I_{LH2}$	–	–	3	$\mu\text{A}$
	$I_{LH2}$	$V_I = V_{DD}$ $X_{in}$ , $X_{out}$ , $XT_{in}$ , and $XT_{out}$			20	
Input Low Leakage Current	$I_{LIL1}$	$V_I = 0\text{ V}$ All input pins except RESET, $X_{in}$ , $X_{out}$ , $XT_{in}$ , and $XT_{out}$	–	–	–3	$\mu\text{A}$
	$I_{LIL2}$	$V_I = 0\text{ V}$ RESET, $X_{in}$ , $X_{out}$ , $XT_{in}$ , and $XT_{out}$			–20	
Output High Leakage Current	$I_{LOH}$	$V_O = V_{DD}$ All output pins	–	–	3	$\mu\text{A}$
Output Low Leakage Current	$I_{LOL}$	$V_O = 0\text{ V}$ All output pins	–	–	–3	$\mu\text{A}$
Pull-Up Resistor	$R_{L1}$	$V_I = 0\text{ V}$ ; $V_{DD} = 5\text{ V}$ Ports 0–4, ports 6–13	25	50	100	$\text{k}\Omega$
		$V_{DD} = 3\text{ V}$	50	100	200	
	$R_{L2}$	$V_I = 0\text{ V}$ ; $V_{DD} = 5\text{ V}$ , RESET	100	250	400	
		$V_{DD} = 3\text{ V}$	200	500	800	
LCD Voltage Dividing Resistor	$R_{LCD}$	–	40	60	90	$\text{k}\Omega$
$ V_{LC1-COMi} $ Voltage Drop ( $i = 0-15$ )	$V_{DC}$	– 15 $\mu\text{A}$ per common pin	–	–	120	mV
$ V_{LC1-SEGx} $ Voltage Drop ( $x = 0-79$ )	$V_{DS}$	– 15 $\mu\text{A}$ per segment pin	–	–	120	
$V_{LC2}$ Output Voltage	$V_{LC2}$	$V_{DD} = 1.8\text{ V to } 5.5\text{ V}$ , 1/5 bias LCD clock = 0 Hz, $V_{LC1} = V_{DD}$	$0.8 V_{DD} - 0.2$	$0.8 V_{DD}$	$0.8 V_{DD} - 0.2$	V
$V_{LC3}$ Output Voltage	$V_{LC3}$		$0.6 V_{DD} - 0.2$	$0.6 V_{DD}$	$0.6 V_{DD} - 0.2$	
$V_{LC4}$ Output Voltage	$V_{LC4}$		$0.4 V_{DD} - 0.2$	$0.4 V_{DD}$	$0.4 V_{DD} - 0.2$	
$V_{LC5}$ Output Voltage	$V_{LC5}$		$0.2 V_{DD} - 0.2$	$0.2 V_{DD}$	$0.2 V_{DD} - 0.2$	

Table 15-2. D.C. Electrical Characteristics (Concluded)

(T<sub>A</sub> = -40 °C to +85 °C, V<sub>DD</sub> = 1.8 V to 5.5 V)

Parameter	Symbol	Conditions		Min	Typ	Max	Units
Supply Current (1)	I <sub>DD1</sub> (2)	V <sub>DD</sub> = 5 V ± 10%	6.0 MHz	-	3.9	8.0	mA
		Crystal oscillator C1 = C2 = 22 pF	4.19 MHz		2.9	5.5	
	I <sub>DD2</sub> (2)	V <sub>DD</sub> = 3 V ± 10%	6.0 MHz		1.8	4.0	
		Idle mode V <sub>DD</sub> = 5 V ± 10%	4.19 MHz		1.3	2.5	
	I <sub>DD3</sub> (3)	V <sub>DD</sub> = 3 V ± 10%	6.0 MHz		1.2	1.8	
		32 kHz crystal oscillator	4.19 MHz		0.5	1.5	
	I <sub>DD4</sub> (3)	V <sub>DD</sub> = 5 V ± 10%	6.0 MHz		0.44	1.0	
		Idle mode; V <sub>DD</sub> = 3 V ± 10%	4.19 MHz		15.3	30	
	I <sub>DD5</sub>	Stop mode; V <sub>DD</sub> = 5 V ± 10%	SCMOD = 0000B X <sub>T<sub>in</sub></sub> = 0V		6.4	15	
		Stop mode; V <sub>DD</sub> = 3 V ± 10%			2.5	5	
V <sub>DD</sub> = 5 V ± 10%		SCMOD = 0100B	0.5	3			
V <sub>DD</sub> = 3 V ± 10%			0.2	3			
			0.1	2			

**NOTES:**

1. Currents in the following circuits are not included; on-chip pull-up resistors, internal LCD voltage dividing resistors, output port drive currents.
2. Data includes power consumption for subsystem clock oscillation.
3. When the system clock control register, SCMOD, is set to 1001B, main system clock oscillation stops and the subsystem clock is used.
4. Every values in this table is measured when the power control register (PCON) is set to "0011B".

Table 15-3. Main System Clock Oscillator Characteristics

(T<sub>A</sub> = -40 °C + 85 °C, V<sub>DD</sub> = 1.8 V to 5.5 V)

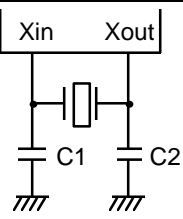
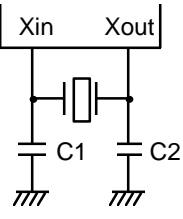
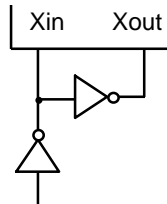
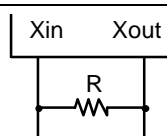
Oscillator	Clock Configuration	Parameter	Test Condition	Min	Typ	Max	Units
Ceramic Oscillator		Oscillation frequency <sup>(1)</sup>	–	0.4	–	6.0	MHz
		Stabilization time <sup>(2)</sup>	Stabilization occurs when V <sub>DD</sub> is equal to the minimum oscillator voltage range; V <sub>DD</sub> = 3.0 V.	–	–	4	ms
Crystal Oscillator		Oscillation frequency <sup>(1)</sup>	–	0.4	–	6.0	MHz
		Stabilization time <sup>(2)</sup>	V <sub>DD</sub> = 2.7 V to 5.5 V	–	–	10	ms
			V <sub>DD</sub> = 1.8 V to 5.5 V	–	–	30	
External Clock		X <sub>in</sub> input frequency <sup>(1)</sup>	–	0.4	–	6.0	MHz
		X <sub>in</sub> input high and low level width (t <sub>xH</sub> , t <sub>xL</sub> )	–	83.3	–	1250	ns
RC Oscillator		Frequency	R = 20 kΩ, V <sub>DD</sub> = 5 V	–	2	–	MHz
			R = 39 kΩ, V <sub>DD</sub> = 3 V	–	1	–	

**NOTES:**

- Oscillation frequency and X<sub>in</sub> input frequency data are for oscillator characteristics only.
- Stabilization time is the interval required for oscillating stabilization after a power-on occurs, or when stop mode is terminated.

Table 15-4. Subsystem Clock Oscillator Characteristics

(T<sub>A</sub> = -40 °C + 85 °C, V<sub>DD</sub> = 1.8 V to 5.5 V)

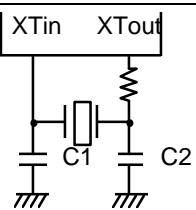
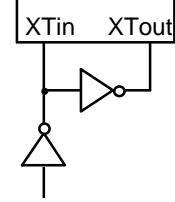
Oscillator	Clock Configuration	Parameter	Test Condition	Min	Typ	Max	Units
Crystal Oscillator		Oscillation frequency (1)	–	32	32.768	35	kHz
		Stabilization time (2)	V <sub>DD</sub> = 2.7 V to 5.5 V	–	1.0	2	s
			V <sub>DD</sub> = 1.8 V to 5.5 V	–	–	10	s
External Clock		XT <sub>in</sub> input frequency (1)	–	32	–	100	kHz
		XT <sub>in</sub> input high and low level width (t <sub>XTL</sub> , t <sub>XTH</sub> )	–	5	–	15	μs

**NOTES:**

- Oscillation frequency and XT<sub>in</sub> input frequency data are for oscillator characteristics only.
- Stabilization time is the interval required for oscillating stabilization after a power-on occurs.

Table 15-5. Input/Output Capacitance

 $(T_A = 25\text{ }^\circ\text{C}, V_{DD} = 0\text{ V})$ 

Parameter	Symbol	Condition	Min	Typ	Max	Units
Input Capacitance	$C_{IN}$	f = 1 MHz; Unmeasured pins are returned to $V_{SS}$	–	–	15	pF
Output Capacitance	$C_{OUT}$		–	–	15	pF
I/O Capacitance	$C_{IO}$		–	–	15	pF

Table 15-6. Comparator Electrical Characteristics

 $(T_A = -40\text{ }^\circ\text{C} + 85\text{ }^\circ\text{C}, V_{DD} = 4.0\text{ V to } 5.5\text{ V}, V_{SS} = 0\text{ V})$ 

Parameter	Symbol	Condition	Min	Typ	Max	Units
Input Voltage Range	–	–	0	–	$V_{DD}$	V
Reference Voltage Range	VREF	–	0	–	$V_{DD}$	V
Input Voltage Accuracy	Internal	VCIN1	–	–	$\pm 150$	mV
	External	VCIN2	–	–	$\pm 150$	mV
Input Leakage Current	ICIN, IREF	–	–3	–	3	$\mu\text{A}$

Table 15-7. LCD Contrast Controller Characteristics

 $(T_A = -40\text{ }^\circ\text{C} + 85\text{ }^\circ\text{C}, V_{DD} = 4.5\text{ V to } 5.5\text{ V})$ 

Parameter	Symbol	Condition	Min	Typ	Max	Units
Resolution	–	–	–	–	4	Bits
Linearity	RLIN	–	–	–	$\pm 1.0$	LSB
Max Output Voltage (LCNST = #8FH)	VLPP	VLC1= $V_{DD}$ =5V	4.9	–	VLC1	V

Table 15-8. A.C. Electrical Characteristics

(T<sub>A</sub> = -40 °C to +85 °C, V<sub>DD</sub> = 1.8 V to 5.5 V)

Parameter	Symbol	Conditions	Min	Typ	Max	Units
Instruction Cycle Time <small>(note)</small>	t <sub>CY</sub>	V <sub>DD</sub> = 2.7 V to 5.5 V	0.67	–	64	μs
		V <sub>DD</sub> = 1.8 V to 5.5 V	0.95		64	
TCL0, TCL1 Input Frequency	f <sub>TI0</sub> , f <sub>TI1</sub>	V <sub>DD</sub> = 2.7 V to 5.5 V	0	–	1.5	MHz
		V <sub>DD</sub> = 1.8 V to 5.5 V			1	
TCL0, TCL1 Input High, Low Width	t <sub>TIH0</sub> , t <sub>TIL0</sub> t <sub>TIH1</sub> , t <sub>TIL1</sub>	V <sub>DD</sub> = 2.7 V to 5.5 V	0.48	–	–	μs
		V <sub>DD</sub> = 1.8 V to 5.5 V	1.8			
SCK Cycle Time	t <sub>KCY</sub>	V <sub>DD</sub> = 2.7 V to 5.5 V; Input	800	–	–	ns
		Output	650			
		V <sub>DD</sub> = 1.8 V to 5.5 V; Input	3200			
		Output	3800			
SCK High, Low Width	t <sub>KH</sub> , t <sub>KL</sub>	V <sub>DD</sub> = 2.7 V to 5.5 V; Input	325	–	–	ns
		Output	t <sub>KCY</sub> /2 – 50			
		V <sub>DD</sub> = 1.8 V to 5.5 V; Input	1600			
		Output	t <sub>KCY</sub> /2 – 150			
SI Setup Time to SCK High	t <sub>SIK</sub>	V <sub>DD</sub> = 2.7 V to 5.5 V; Input	100	–	–	ns
		V <sub>DD</sub> = 2.7 V to 5.5 V; Output	150			
		V <sub>DD</sub> = 1.8 V to 5.5 V; Input	150			
		V <sub>DD</sub> = 1.8 V to 5.5 V; Output	500			
SI Hold Time to SCK High	t <sub>KSI</sub>	V <sub>DD</sub> = 2.7 V to 5.5 V; Input	400	–	–	ns
		V <sub>DD</sub> = 2.7 V to 5.5 V; Output	400			
		V <sub>DD</sub> = 1.8 V to 5.5 V; Input	600			
		V <sub>DD</sub> = 1.8 V to 5.5 V; Output	500			

**NOTE:** Unless otherwise specified, Instruction Cycle Time condition values assume a main system clock ( f<sub>x</sub> ) source.

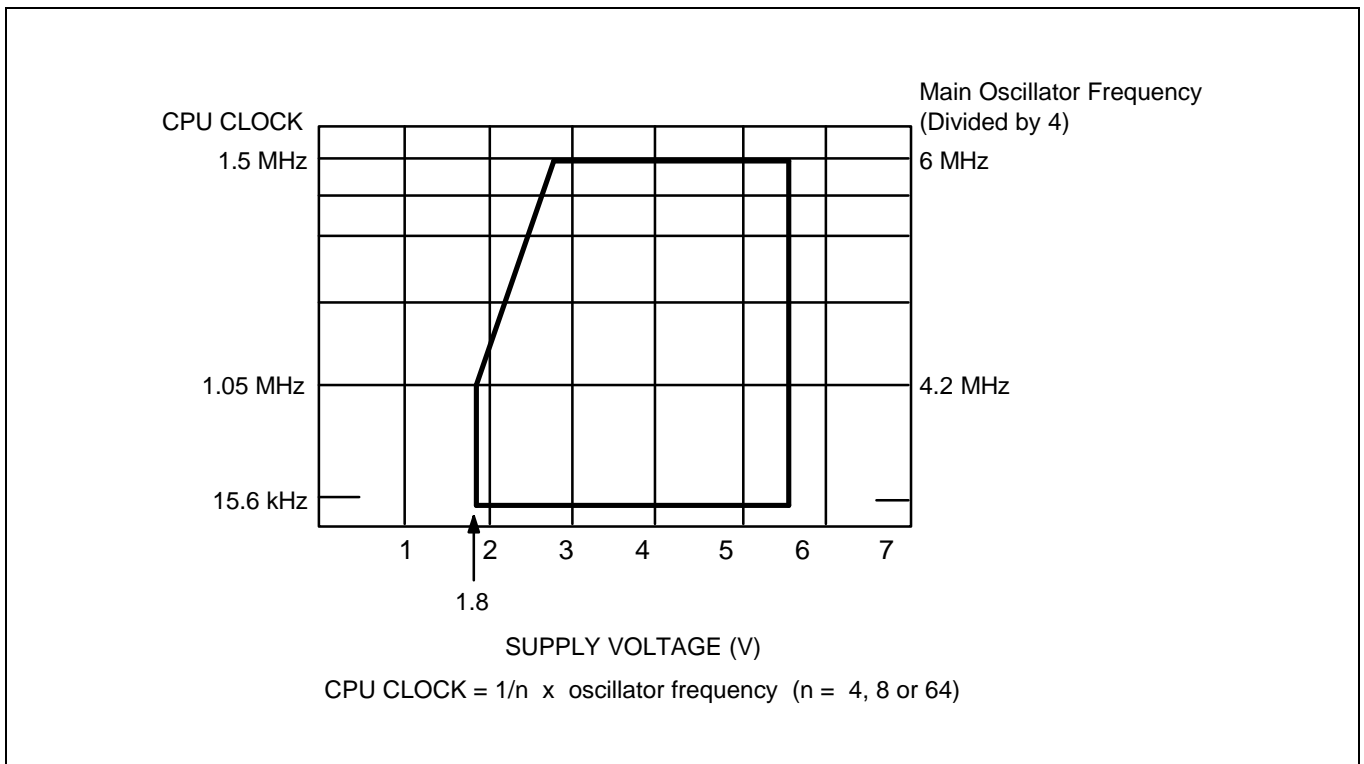

**Table 15-8. A.C. Electrical Characteristics (Continued)**

( $T_A = -40\text{ }^\circ\text{C}$  to  $+85\text{ }^\circ\text{C}$ ,  $V_{DD} = 1.8\text{ V}$  to  $5.5\text{ V}$ )

Parameter	Symbol	Conditions	Min	Typ	Max	Units
Output Delay for SCK to SO	$t_{KSO}$	$V_{DD} = 2.7\text{ V}$ to $5.5\text{ V}$ ; Input	-	-	300	ns
		$V_{DD} = 2.7\text{ V}$ to $5.5\text{ V}$ ; Output			250	
		$V_{DD} = 1.8\text{ V}$ to $5.5\text{ V}$ ; Input			1000	
		$V_{DD} = 1.8\text{ V}$ to $5.5\text{ V}$ ; Output			1000	
Interrupt Input High, Low Width	$t_{INTH}$ , $t_{INTL}$	INT0, INT1, INT2, INT4, K0-K7	10	-	-	$\mu\text{s}$
RESET Input Low Width	$t_{RSL}$	Input	10	-	-	$\mu\text{s}$

**NOTE:** Minimum value for INT0 is based on a clock of  $2t_{CY}$  or  $128 / f_x$  as assigned by the IMOD0 register setting.



**Figure 15-1. Standard Operating Voltage Range**

Table 15-9. RAM Data Retention Supply Voltage in Stop Mode

(T<sub>A</sub> = -40 °C to +85 °C)

Parameter	Symbol	Conditions	Min	Typ	Max	Unit
Data retention supply voltage	V <sub>DDDR</sub>	–	1.8	–	5.5	V
Data retention supply current	I <sub>DDDR</sub>	V <sub>DDDR</sub> = 1.8 V	–	0.1	1	μA
Release signal set time	t <sub>SREL</sub>	–	0	–	–	μs
Oscillator stabilization wait time (1)	t <sub>WAIT</sub>	Released by RESET	–	2 <sup>17</sup> / fx	–	ms
		Released by interrupt	–	(2)	–	

**NOTES:**

1. During oscillator stabilization wait time, all CPU operations must be stopped to avoid instability during oscillator start-up.
2. Use the basic timer mode register (BMOD) interval timer to delay execution of CPU instructions during the wait time.

TIMING WAVEFORMS

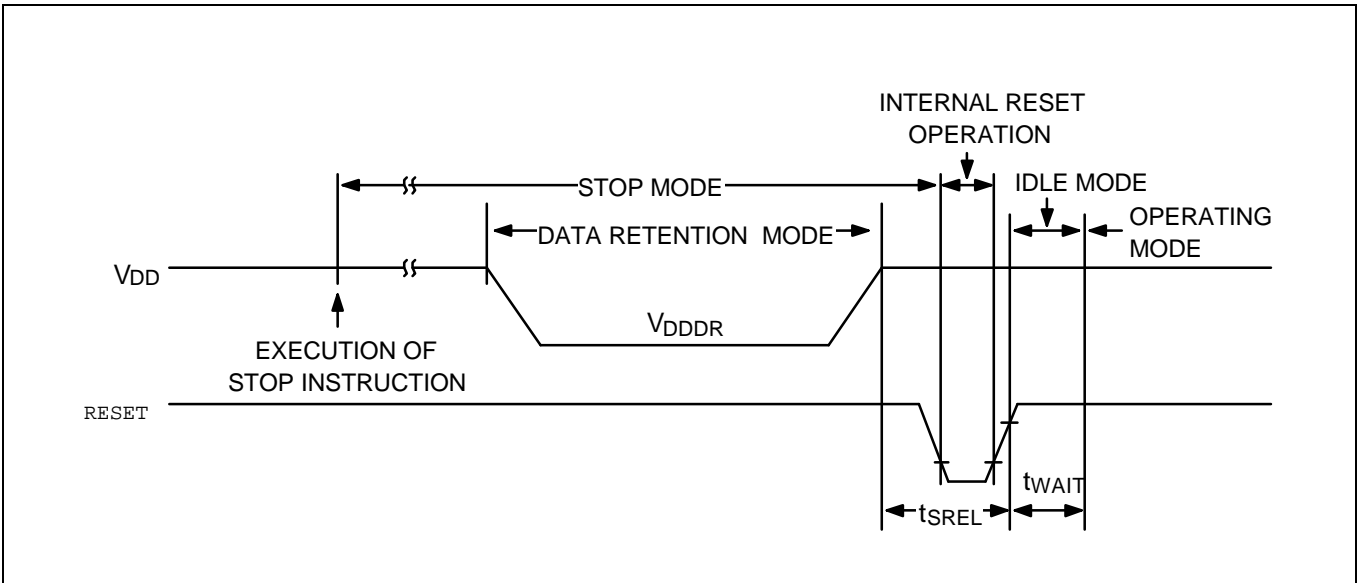

Figure 15-2. Stop Mode Release Timing When Initiated By RESET

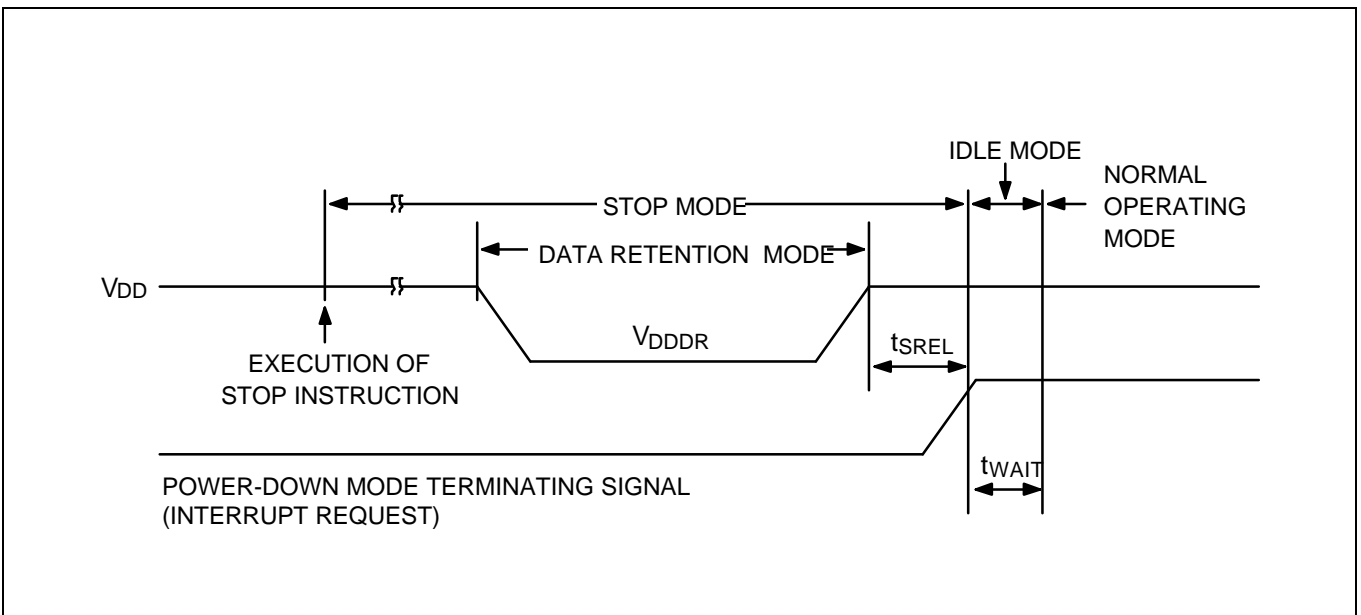

Figure 15-3. Stop Mode Release Timing When Initiated By Interrupt Request

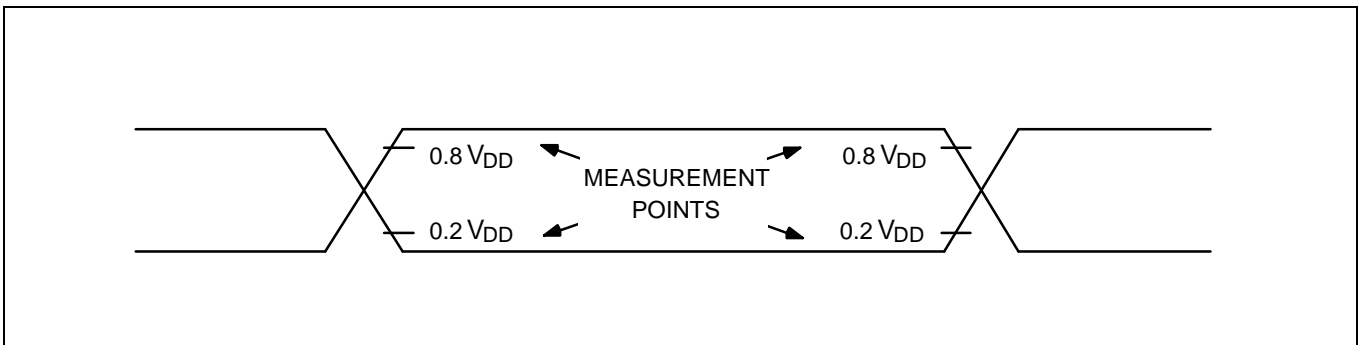

Figure 15-4. A.C. Timing Measurement Points (Except for  $X_{in}$  and  $XT_{in}$ )

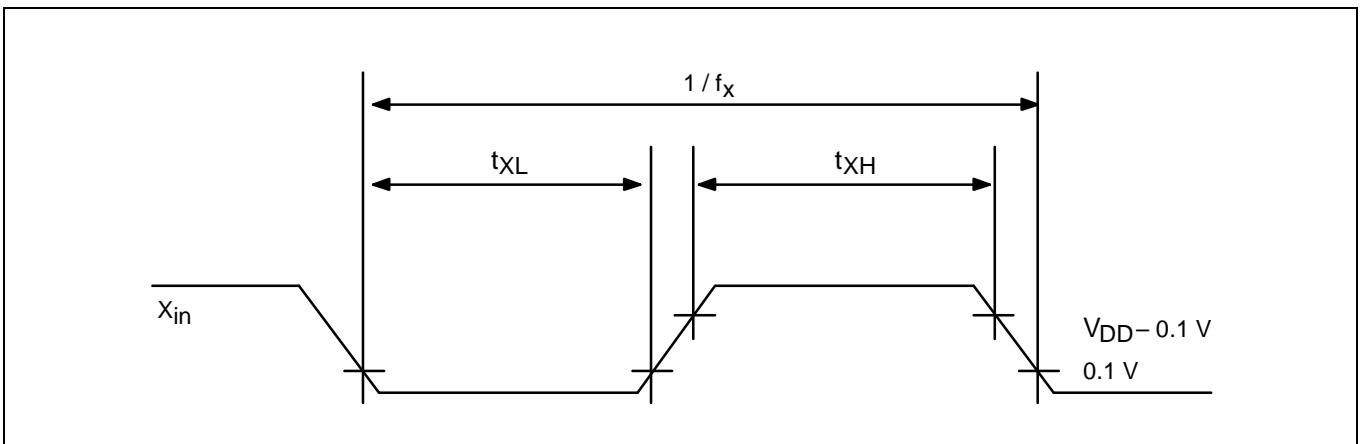

Figure 15-5. Clock Timing Measurement at  $X_{in}$

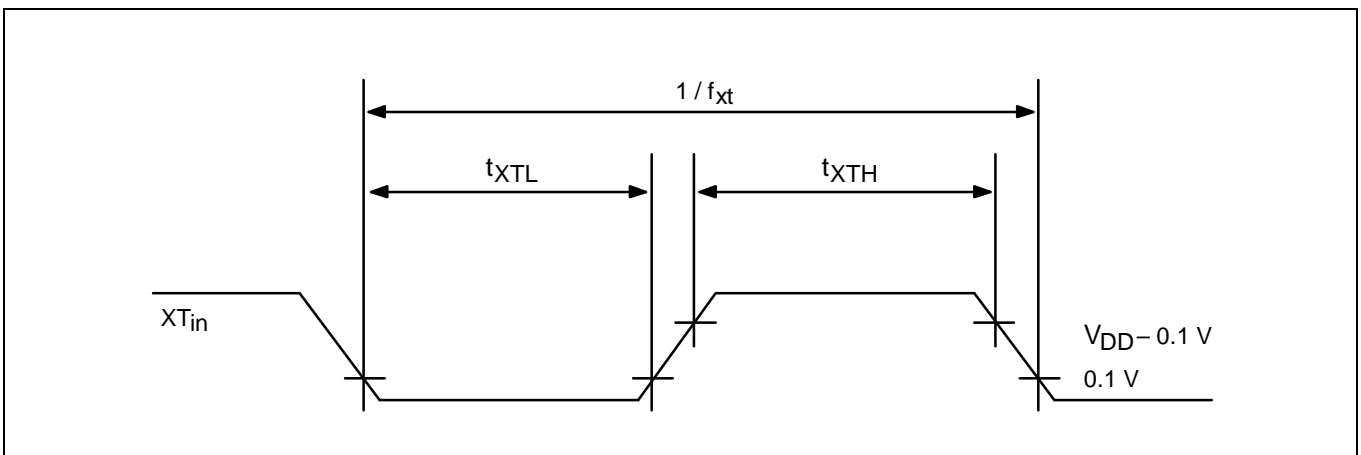

Figure 15-6. Clock Timing Measurement at  $XT_{in}$

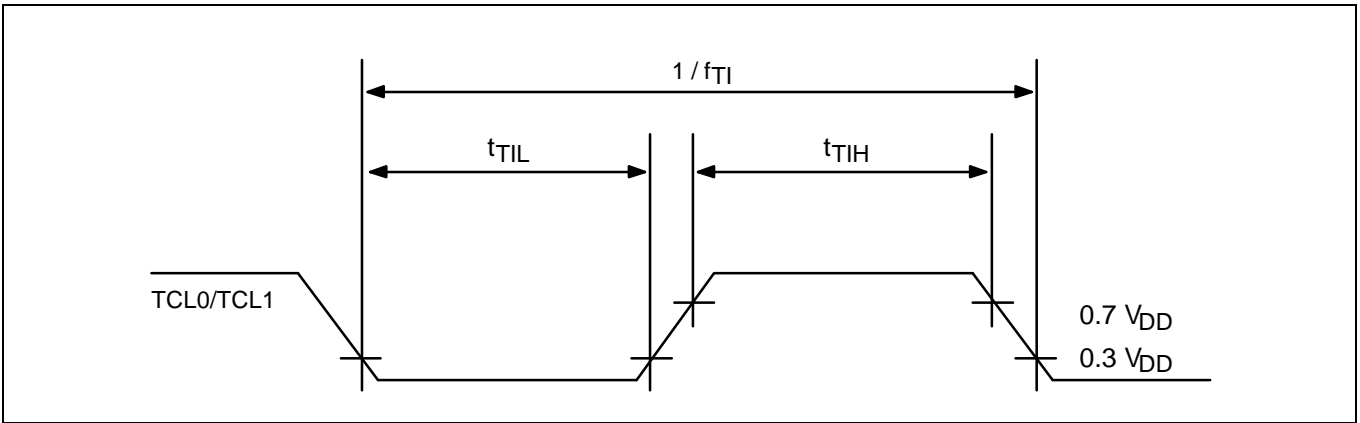

Figure 15-7. TCL0/TCL1 Timing

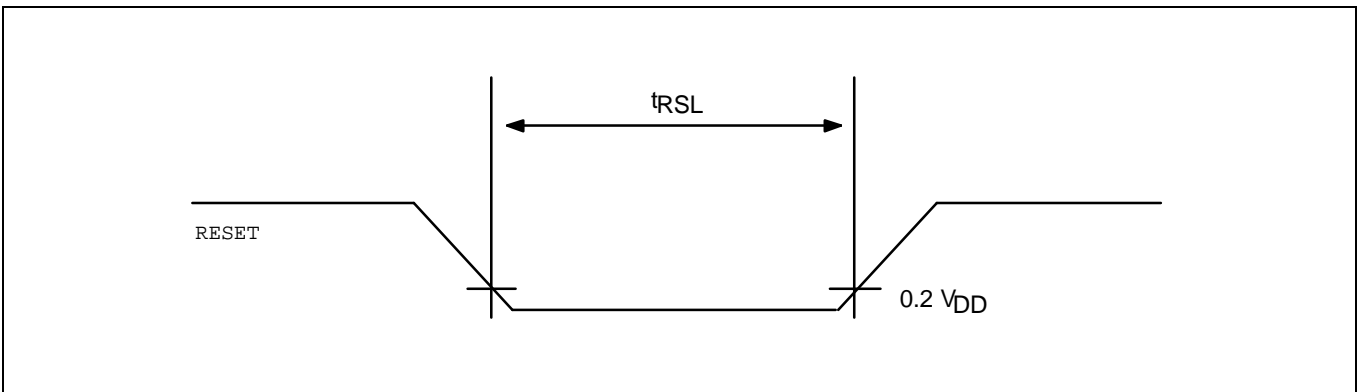

Figure 15-8. Input Timing for RESET Signal

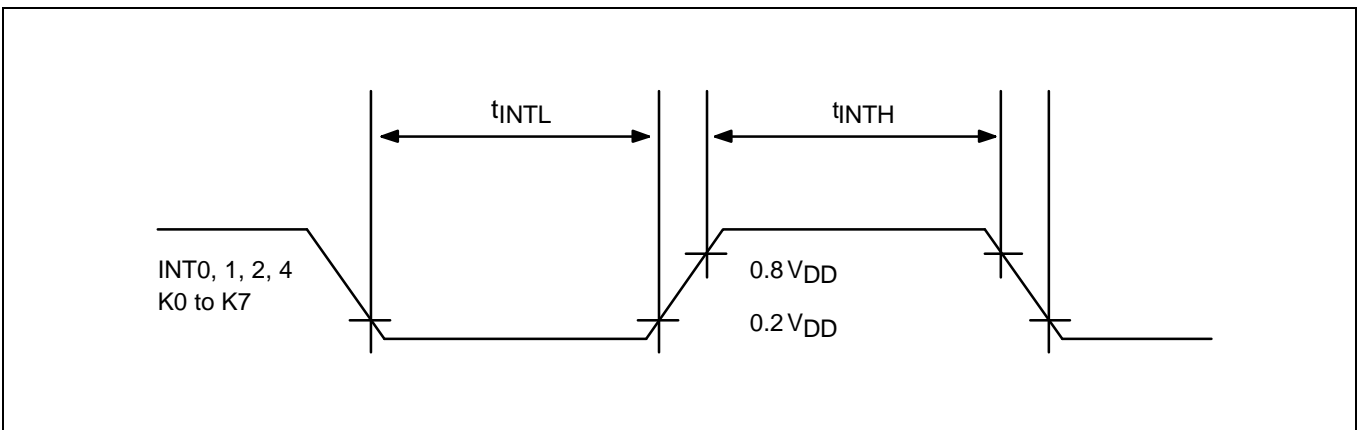

Figure 15-9. Input Timing for External Interrupts and Quasi-Interrupts

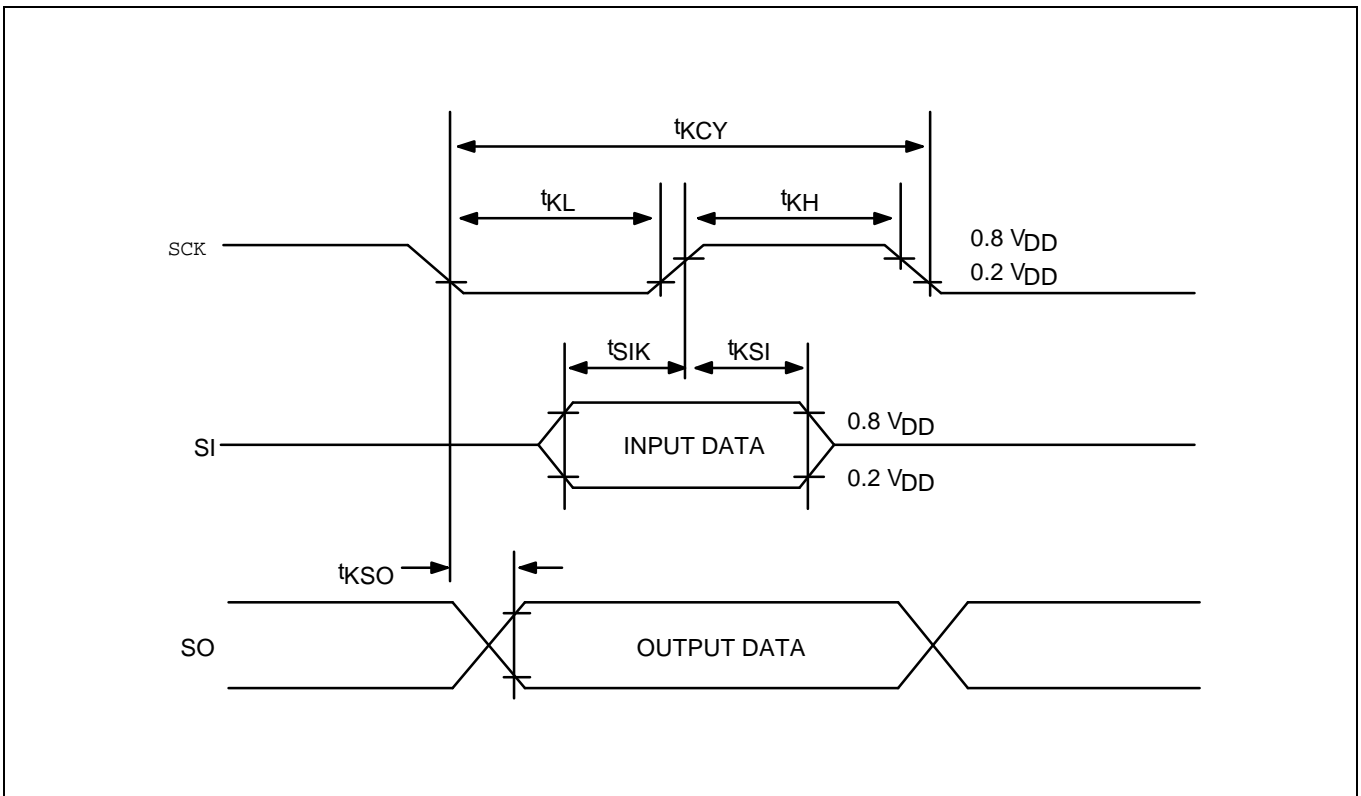

Figure 15-10. Serial Data Transfer Timing

# 16 MECHANICAL DATA

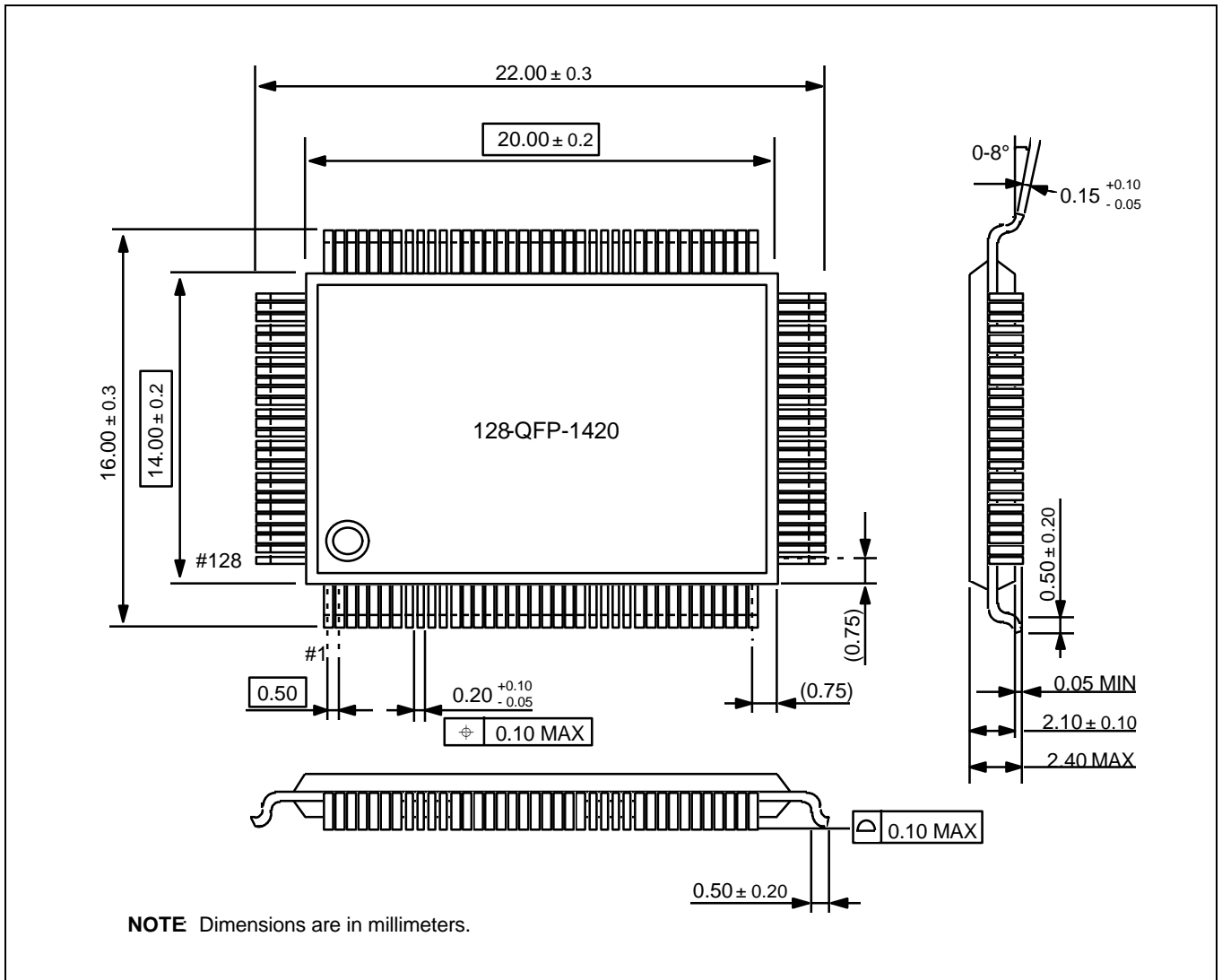

Figure 16-1. 128-QFP-1420 Package Dimensions

**NOTES**



# 17

## KS57P21132 OTP

### OVERVIEW

The KS57P21132 single-chip CMOS microcontroller is the OTP (One Time Programmable) version of the KS57C21116/C21124/C21132 microcontroller. It has an on-chip OTP ROM instead of masked ROM. The EPROM is accessed by serial data format.

The KS57P21132 is fully compatible with the KS57C21116/C21124/C21132, both in function and in pin configuration except ROM size. Because of its simple programming requirements, the KS57P21132 is ideal for use as an evaluation chip for the KS57C21116/C21124/C21132.

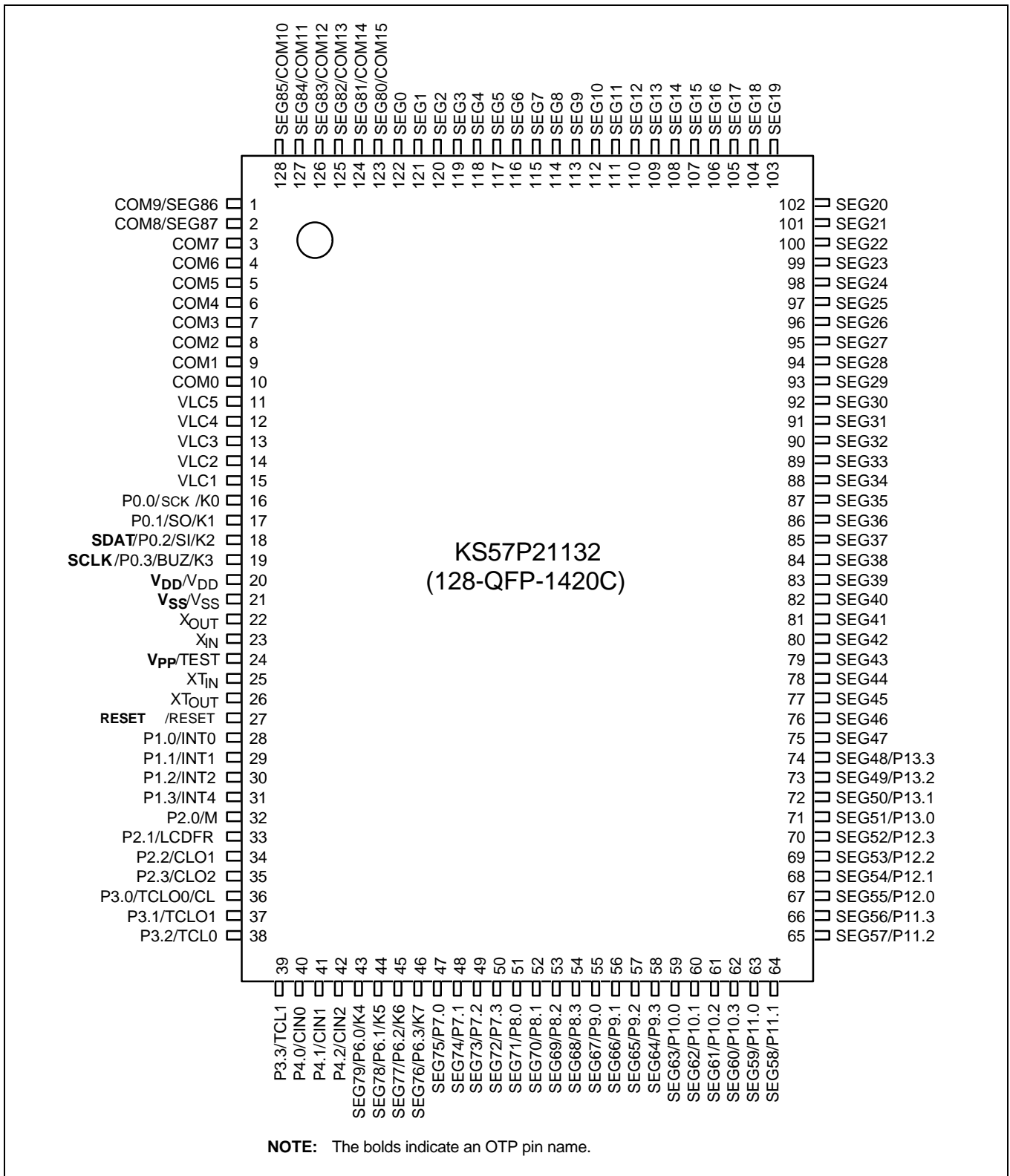

Figure 17-1. KS57P21132 Pin Assignments (128-QFP Package)

Table 17-1. Descriptions of Pins Used to Read/Write the EPROM

Main Chip Pin Name	During Programming			
	Pin Name	Pin No.	I/O	Function
P0.2	SDAT	18	I/O	Serial data pin. Output port when reading and input port when writing. Can be assigned as a Input / push-pull output port.
P0.3	SCLK	19	I/O	Serial clock pin. Input only pin.
TEST	V <sub>PP</sub> (TEST)	24	I	Power supply pin for EPROM cell writing (indicates that OTP enters into the writing mode). When 12.5 V is applied, OTP is in writing mode and when 5 V is applied, OTP is in reading mode. (Option)
RESET	RESET	27	I	Chip Initialization
V <sub>DD</sub> /V <sub>SS</sub>	V <sub>DD</sub> /V <sub>SS</sub>	20/21	I	Logic power supply pin. V <sub>DD</sub> should be tied to +5 V during programming.

Table 17-2. Comparison of KS57P21132 and KS57C21116/C21124/C21132 Features

Characteristic	KS57P21132	KS57C21116/C21124/C21132
Program Memory	32-Kbyte EPROM	16/24/32-Kbyte mask ROM
Operating Voltage (V <sub>DD</sub> )	1.8 V to 5.5 V	1.8 V to 5.5 V
OTP Programming Mode	V <sub>DD</sub> = 5 V, V <sub>PP</sub> (TEST) = 12.5V	
Pin Configuration	128 QFP	128 QFP
EPROM Programmability	User Program 1 time	Programmed at the factory

## OPERATING MODE CHARACTERISTICS

When 12.5 V is supplied to the V<sub>PP</sub> (TEST) pin of the KS57P21132, the EPROM programming mode is entered. The operating mode (read, write, or read protection) is selected according to the input signals to the pins listed in Table 17-3 below.

Table 17-3. Operating Mode Selection Criteria

V <sub>DD</sub>	V <sub>PP</sub> (TEST)	REG/MEM	ADDRESS (A15-A0)	R/W	MODE
5 V	5 V	0	0000H	1	EPROM read
	12.5 V	0	0000H	0	EPROM program
	12.5 V	0	0000H	1	EPROM verify
	12.5 V	1	0E3FH	0	EPROM read protection

**NOTE:** "0" means Low level; "1" means High level.

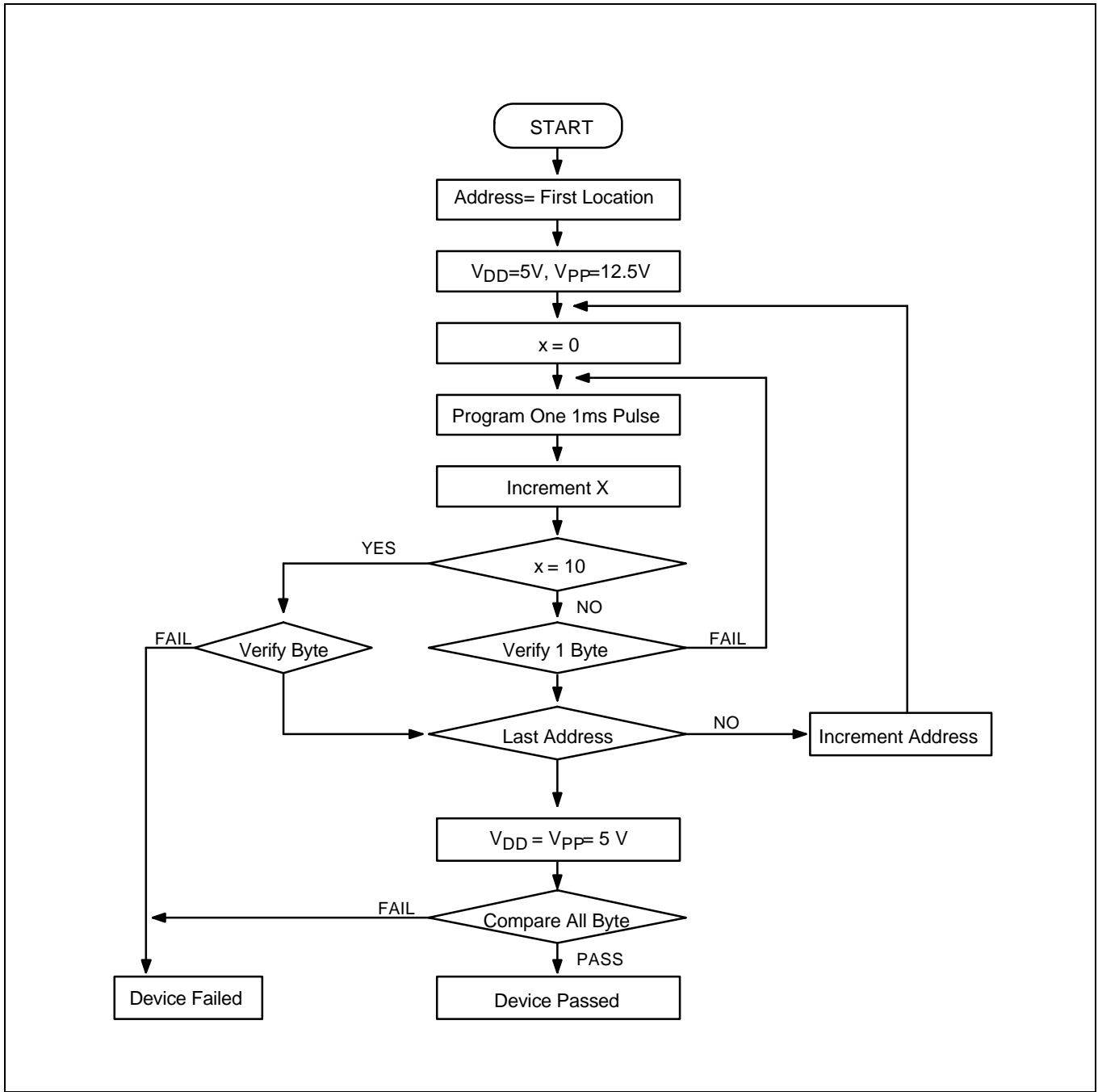

Figure 17-2. OTP Programming Algorithm

Table 17-4. D.C. Electrical Characteristics

(T<sub>A</sub> = -40 °C to +85 °C, V<sub>DD</sub> = 1.8 V to 5.5 V)

Parameter	Symbol	Conditions		Min	Typ	Max	Units		
Supply Current (1)	I <sub>DD1</sub> (2)	V <sub>DD</sub> = 5 V ± 10%	6.0 MHz	-	3.9	8.0	mA		
		Crystal oscillator C1 = C2 = 22 pF	4.19 MHz		2.9	5.5			
	I <sub>DD2</sub> (2)	V <sub>DD</sub> = 3 V ± 10%	6.0 MHz		1.8	4.0			
		Idle mode V <sub>DD</sub> = 5 V ± 10%	4.19 MHz		1.3	3.0			
	I <sub>DD3</sub> (3)	Crystal oscillator C1 = C2 = 22 pF	6.0 MHz		1.3	2.5			
		V <sub>DD</sub> = 3 V ± 10%	4.19 MHz		1.2	1.8			
	I <sub>DD4</sub> (3)	V <sub>DD</sub> = 5 V ± 10%	6.0 MHz		0.5	1.5			
		32 kHz crystal oscillator	4.19 MHz		0.44	1.0			
	I <sub>DD5</sub>	Idle mode; V <sub>DD</sub> = 3 V ± 10%	32 kHz crystal oscillator		-	15.3		30	μA
		Stop mode; V <sub>DD</sub> = 5 V ± 10%	SCMOD = 0000B XT <sub>in</sub> = 0V		6.4	15			
Stop mode; V <sub>DD</sub> = 3 V ± 10%			2.5	5					
V <sub>DD</sub> = 5 V ± 10%		SCMOD = 0100B	0.5	3					
	V <sub>DD</sub> = 3 V ± 10%		0.2	3					
			0.1	2					

**NOTES:**

1. Currents in the following circuits are not included; on-chip pull-up resistors, internal LCD voltage dividing resistors, output port drive currents.
2. Data includes power consumption for subsystem clock oscillation.
3. When the system clock control register, SCMOD, is set to 1001B, main system clock oscillation stops and the subsystem clock is used.
4. Every values in this table is measured when the power control register (PCON) is set to "0011B".

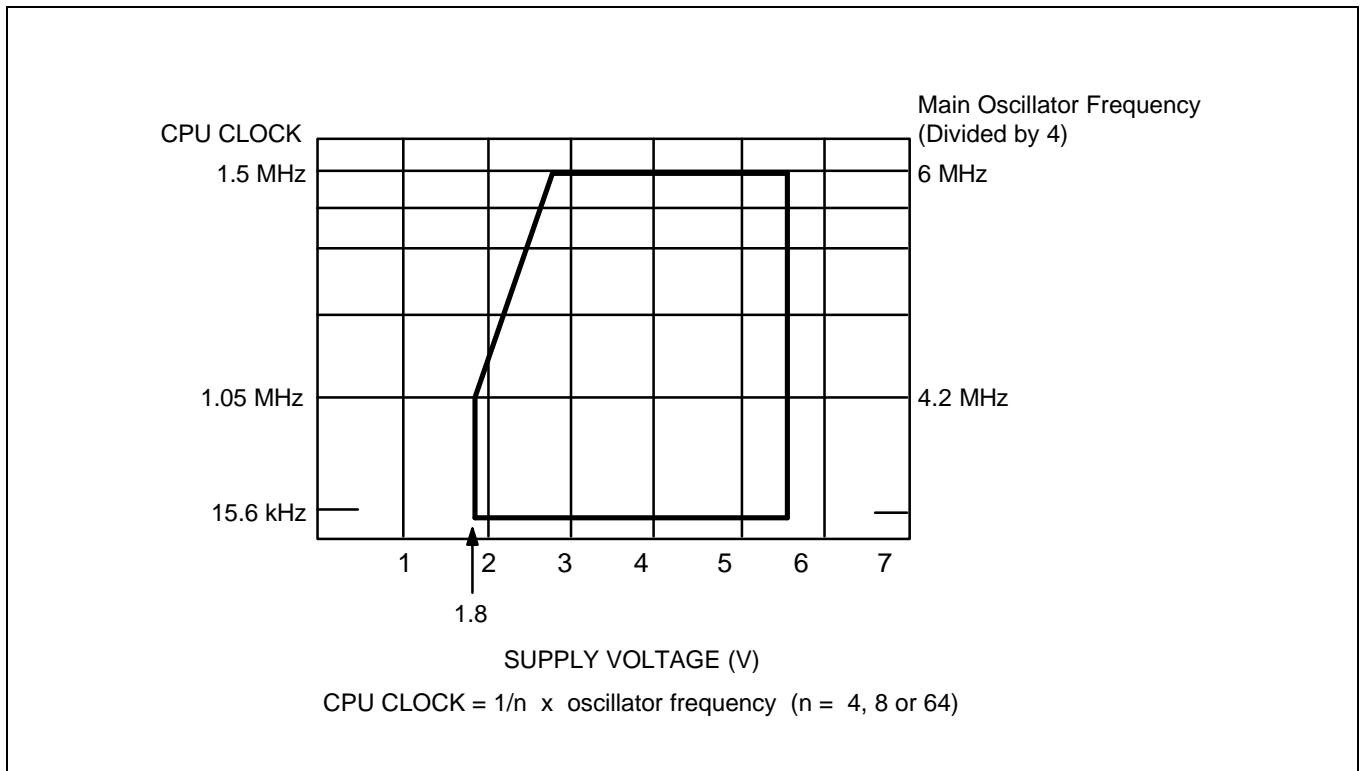

Figure 17-3. Standard Operating Voltage Range